



WINDOW TECHNOLOGY
DOOR TECHNOLOGY
AUTOMATIC ENTRANCE SYSTEMS
BUILDING MANAGEMENT SYSTEMS



WINDOW TECHNOLOGY – ORDER CATALOGUE

Smoke and heat exhaust ventilation systems Ventilation and fanlight opening systems

Edition 08/2023

- Drive technology
- Control technology
- Fanlight opening systems

Securing technology for you



The Gretsch-Unitas group

Opening, moving, closing, securing – true to its motto "Securing technology for you", Gretsch-Unitas group provides groundbreaking solutions for window and door technology, automatic entrance systems and building management systems. With its system brands, the group delivers solutions for burglar inhibition on doors and windows, for barrier-free building, for doors in escape and rescue routes, extending to individual facade solutions for projects.



Gretsch-Unitas GmbH Baubeschläge



GU in Ditzingen is the headquarters of the group, development, administration and the production of modern architectural hardware for window and door technology. Apart from different flexible assembly departments, the production site comprises a high-tech punching and galvanising facility.

BKS GmbH



BKS manufactures mechanical and electronic locking cylinders, locks, locking systems and panic locks for escape and rescue routes. Harmonised mechanical and electronic system solutions are available for access control.

FERCO International S.A.S.



Ferco is the largest production site for window hardware in France. As a subsidiary of the Gretsch-Unitas group, Ferco also offers customer support and distribution in France for all products of the group.



GU Automatic



GU Automatic offers innovative, secure and reliable solutions for automatic entrance systems and automatic door systems, revolving doors, all-glass sliding walls, security curved sliding doors and controlled physical access.

ela-soft



The successful GEMOS facility management and organisation system was designed by ela-soft, one of the market and technology leaders in the building technology branch.

Securing technology for you



The GU barcode scanner app



General notes

All article numbers have a barcode in our catalogue. These barcodes make it possible to register article numbers quickly and correctly, and also avoids errors when entering numbers manually.

The barcodes are easy to scan and only the **GU barcode scanner app** is required.

The GU barcode scanner app can be used by every GU customer who has access* to our **"Customer Information System (CIS)"** webshop.

Installation of the app

Android operating system

- Search for "GU barcode scanner" in the Google Play Store (developed by Evolvece GmbH)
- Install the app on a smartphone or tablet with Android operating system (Version 5.0 or higher) or use this link:

<https://play.google.com/store/apps/details?id=com.gu.scanner&gl=DE>

Operating system iOS

- Search for "GU barcode scanner" in the Apple Store (developed by Evolvece GmbH) or use this link:

<https://apps.apple.com/de/app/gu-barcodescanner/id1623667275>

Support

If you have any questions or problems regarding the GU barcode scanner-app, please get in touch with our support team by e-mail: transfermanager@g-u.de

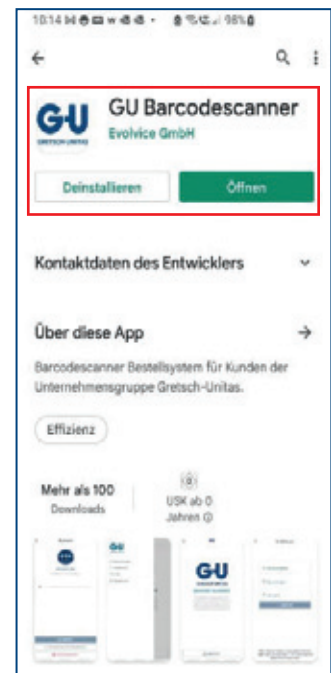
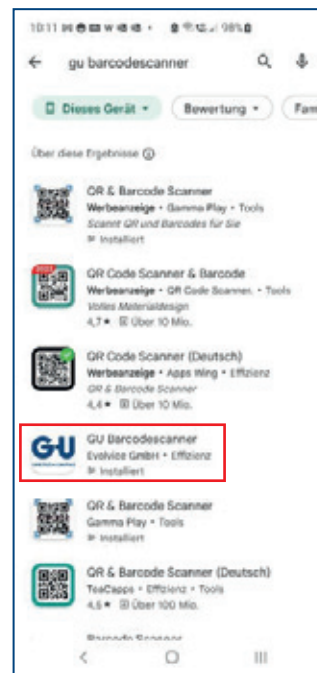



1.0 Drive technology

Table of contents

7

2.0 Control technology

Table of contents

233

3.0 Fanlight opening systems

Table of contents

323

4.0 Additional information

Table of contents

441





1.0 Drive technology

1.1 Chain drives

Table of contents

13

1.2 Locking drives

Table of contents

111

1.3 Spindle drives

Table of contents

135

1.4 Door drives | Window drives

Flap lever drives

Table of contents

179

1.5 SHEV hardware systems

Table of contents

193

1.6 Accessories

Table of contents

221

Electric drive and opening systems

Product overview



Designation	Chain drives									
	KS2				KS4			KSA		
Specification	S12 24 V	TWIN S12 24 V	S12 230 V	S12 230 V Tandem	S12 24 V	S12 24 V R+L elongated	Dreh-volution	S12 24 V	TWIN S12 24 V	S12 230 V
Pages	16 – 33				34 – 49			50 – 66		
Bottom-Hung window	inward	■	■	■	■	-	-	■	■	■
	outward	■	■	■	■	-	-	■	■	■
Top-Hung window	outward	●	●	●	■	-	-	■	■	■
Side-Hung window	inward	■	■	■	■	■	■	■	■	■
	outward	■	■	■	■	-	-	■	■	■
Skylight	outward	-	-	-	-	-	-	■	■	■
Profile-integrated assembly	■				■	■	-	-		
Nominal voltage	24 V DC ± 15 %	24 V DC ± 15 %	230 V AC	230 V AC	24 V DC ± 15 %	24 V DC ± 15 %	24 V DC ± 15 %	24 V DC ± 15 %	24 V DC ± 15 %	230 V AC
Nominal current [A]	0.7	1.4	0.13	0.15	0.9	0.9	0.9	0.9	1.8	0.2
Breaking current [A]	1.0	2.0	0.2	0.2	1.2	1.2	1.2	1.2	2.4	0.2
Nominal power [W]	17	34	30	35	22	22	22	22	43	46
Duty ratio [%]	30	30	30	30	30	30	30	30	30	30
Protection code [IP]	32	32	32	32	32	32	32	32	32	32
Ambient temperature [°C]	-5 to +60	-5 to +60	-5 to +60	-5 to +60	-5 to +60	-5 to +60	-5 to +60	-5 to +60	-5 to +60	-5 to +60
Max. pulling force [N]	250	250	250	250	400	200	400	600	1200	600
Max. locking force (depending on attachment) [N]	1800	2 x 1800	1800	1800	1800	1800	1800	3000	2 x 2500	3000
Connecting cable	~ 3 m 3 x 0.5 mm ² 5 x 0.5 mm ² (Z version)	~ 3 m 3 x 0.5 mm ² 5 x 0.5 mm ² (Z version)	~ 3 m 6 x 0.75 mm ²	~ 3 m Master: 6 x 0.75 mm ² 3 x 0.5 mm ² Slave: 3 x 0.5 mm ²	~ 2 m 5 x 0.5 mm ²	~ 2 m 5 x 0.5 mm ²	~ 2 m 5 x 0.5 mm ²	~ 3 m 5 x 0.5 mm ²	~ 3 m 5 x 0.5 mm ²	~ 3 m 6 x 0.75 mm ²
Max. travel speed [mm/s]	13.5	12.0	8.0	8.0	13.5	8.0	8.0	13.5	12.0	8.0
Travel [mm]	200 300 400 500 600 800	200 400 500 600	200 300 400 500 600 800	200 300 400 500 600 800	200 300 400 500 600 800 1000	400	350	250 300 400 500 600 800 1000 1200 1500	400 500 600	250 300 400 500 600 800 1000 1200 1500
Dimensions LxHxD [mm]	Lx26x41	Lx26x41	Lx26x41	Lx26x41	Lx24x35	551x24x35	551x24x35	Lx40x56	Lx40x56	Lx40x56

[1] Due to its plastic case, the drive is not approved for SHEV use within the EU!

■ suitable | ● less suitable

Electric drive and opening systems

Product overview



Chain drives

KS15		ELTRAL KS20 [1]	ELTRAL K30		ELTRAL KS 30/40 [1]			ELTRAL K35
S12 24 V	S12 230 V	24 V	24 V	230 V	24 V	230 V	230 V wireless	24 V
68 – 75		76 – 79	80 – 87		88 – 99			100 – 109
-	-	■	■	■	■	■	■	■
-	-	■	■	■	■	■	■	■
■	■	●	■	■	■	■	■	■
-	-	■	■	■	■	■	■	■
-	-	■	■	■	■	■	■	■
■	■	-	-	-	-	-	-	-
-	-	■	-	-	-	-	-	■
24 V DC ± 15 %	230 V AC	24 V DC ± 15 %	24 V DC ± 15 %	230 V AC	24 V DC ± 15 %	230 V AC	230 V AC	24 V DC ± 15 %
3.75	0.45	0.45	0.9	0.16	0.9	0.12	0.16	0.9
5.0	0.6	1.0	1.2	-	1.2	-	-	1.2
90	103	11	22	37	22	28	37	22
30	30	30	30	30	30	30	30	30
20	20	42	32	32	30	30	30	32
-5 to +60	-5 to +60	-5 to +60	-5 to +60	-5 to +60	-5 to +60	-5 to +60	-5 to +60	-5 to +60
1500	1500	200	300	300	300	300	300	350
5000	5000	1000	2000	2000	1000	1000	1000	3000
~ 3 m 5 x 1.0 mm ²	~ 3 m 6 x 0.75 mm ²	~ 2 m 3 x 0.5 mm ²	~ 2 m; 3 x 0.5 mm ² (Solo) ~ 2.5 m; 5 x 0.5 mm ² (Synchro)	~ 2 m; 3 x 0.5 mm ² (Solo) ~ 2.5 m; 5 x 0.5 mm ² (Synchro)	~ 2 m; 3 x 0.75 mm ² (Solo) ~ 2.5 m; 5 x 0.75 mm ² (Synchro)	~ 2 m; 3 x 0.75 mm ² (Solo) ~ 2.5 m; 5 x 0.75 mm ² (Synchro)	~ 2 m; 3 x 0.75 mm ²	~ 2 m; 3 x 0.5 mm ² (Solo) ~ 2.5 m; 5 x 0.5 mm ² (Synchro)
17.0	17.0	4.0	8.9	8.9	9.0	9.0	10.0	9.6
800 1000	1000	250/170/100 variable adjustment	500/400/300 variable adjustment	500/400/300 variable adjustment	400/300/200 variable adjustment	400/300/200 variable adjustment	400/300/200 variable adjustment	100/200/300 300/400/500 600/700/800 variable adjustment
Lx60x120	Lx60x120	354x21x28	456x43x60	456x43x60	386x38x58	386x38x58	386x38x58	Lx35x35

Electric drive and opening systems

Product overview



Designation	Locking drives					Spindle drives			
	ELTRAL VAN	FVUx			OFV M-COM	PLA		PLS	SP
FVUI		FVUR	FVUB	PLA8		PLA10	PLS15	SP8-Z	
Pages	114 – 117	118 – 131			132 – 133	138 – 153		154 – 169	170 – 176
Bottom-Hung window	inward	■	■	■	■	-	-	-	-
	outward	■	■	■	■	-	-	-	-
Top-Hung window	outward	■	■	■	■	-	-	-	-
Side-Hung window	inward	■	■	■	■	-	-	-	-
	outward	■	■	■	■	-	-	-	-
Skylight	outward	-	-	-	-	■	■	■	■
Profile-integrated assembly	■	■	-	-	-	-	-	-	-
Nominal voltage	24 V DC ± 15 %	24 V DC ± 15 %	24 V DC ± 15 %	24 V DC ± 15 %	24 V DC ± 15 %	24 V DC ± 15 %	24 V DC ± 15 %	24 V DC ± 15 %	230 V AC
Nominal current [A]	1.5	0.6	0.6	0.6	0.8	1.0	1.9	3.0	0.12
Breaking current [A]	1.5	~ 1.0	~ 1.0	~ 1.0	1.1	1.4	2.5	4.0	0.2
Nominal power [W]	-	15	15	15	19	24	45	72	5
Duty ratio [%]	30	30	30	30	30	30	30	30	30
Protection code [IP]	43	32	32	32	32	65	65	54	54
Ambient temperature [°C]	-5 to +60	-5 to +60	-5 to +60	-5 to +60	-5 to +60	-5 to +60	-5 to +60	-5 to +60	-5 to +60
Max. pulling force [N]	350	-	-	-	-	800	1000	1500	800
Max. break-away force [N]	-	~ 1000	~ 1000	~ 1000	-	-	-	-	-
Force (torque) max. [Nm]	-	-	-	-	10	-	-	-	-
Max. locking force (depending on attachment) [N]	850	1500	1500	1500	-	5000	5000	25000	3000
Max. blocking moment [Nm]	-	-	-	-	22	-	-	-	-
Connecting cable	~ 2 m; 3 x 0.75 mm ²	~ 3 m; 3 x 0.5 mm ²	~ 3 m; 3 x 0.5 mm ²	~ 3 m; 3 x 0.5 mm ²	~ 3 m; 3 x 0.5 mm ²	~ 3 m; 3 x 1.0 mm ²	~ 3 m; 3 x 1.0 mm ²	~ 3 m; 3 x 1.0 mm ²	~ 1 m; 6 x 0.75 mm ²
Max. travel speed [mm/s]	6.0	-	-	-	20°/s	10.0	12.6	16.0	7.0
Runtime [s]	-	~ 5.0	~ 5.0	~ 5.0	~ 4.5 s (90°) ~ 9.0 s (180°)	-	-	-	-
Opening width/travel [mm]	18 / 35 adjustable	~ 18	~ 18	~ 18	90° / 180° adjustable	100 200 300 400 500 600 750 1000	100 200 300 400 500 600 750 1000	300 400 500 600 750 1000 1200	300 400 500 600 750
Opening angle (lever) [DEG]	-	-	-	-	-	-	-	-	-
Dimensions LxHxD [mm]	353x25x25	415x26x26	415x26x26	415x26x26	156x40x83.5	Ø36x- (342+travel)	Ø36x- (342+travel)	Ø50x- (465+travel)	Lx43x76

[1] FTA600 R: no connection to moving parts (roller)

■ suitable | ● less suitable

Electric drive and opening systems

Product overview



Flap lever drives	SHEV hardware systems									
	FTA600	SHEV 1000 with PL10 spindle drive			SHEV 1100 with PL10 spindle drive			SHEV 1050 with PL6 spindle drive		
	FTA600 R DF GF	Solo		Synchro	Solo		Synchro	Solo		Synchro
	with FV	with OFV	with FV/OFV	with FV	with OFV	with FV/OFV	with FV	with OFV	with FV/OFV	
182 – 191	196 – 219									
-	■			-			-			
-	-			■			-			
-	-			■			-			
■	■			-			■			
■	-			■			-			
-	-			-			-			
-	-			-			-			
24 V DC ± 15 %	24 V DC ± 15 %			24 V DC ± 15 %			24 V DC ± 15 %			
1.0	0.6	0.8	1.2	0.6	0.8	1.2	0.6	0.8	1.2	
1.4	0.8	1.1	1.6	0.8	1.1	1.6	0.8	1.1	1.6	
24	15	19	29	15	19	29	15	19	29	
30	20			20			20			
32	65			65			65			
-5 to +60	-5 to +60			-5 to +60			-5 to +60			
-	1000			1000			600			
-	-			-			-			
~ 215	-			-			-			
3000 [1]	5000			5000			5000			
-	-			-			-			
~ 3 m; 5 x 0.5 mm ²	~ 3 m; 2 x 0.75 mm ²			~ 3 m; 2 x 0.75 mm ²			~ 3 m; 2 x 0.75 mm ²			
-	2.6			2.6			5.8			
45.0	-			-			-			
-	100 150 200 250 300			100 150 200 250 300			100 150 200 250			
0 – 93 (± 5 %)	-			-			-			
421x40x101	Ø36x(256+travel)			Ø36x(256+travel)			Ø36x(256+travel)			





1.1 Chain drives 24 V DC / 230 V AC

Chain drive KS2	16
Chain drive KS4	34
Chain drive KSA	50
Chain drive KS15	68
Chain drive ELTRAL KS20	76
Chain drive ELTRAL K30	80
Chain drive ELTRAL KS 30/40	88
Chain drive ELTRAL K35	100

Chain drives

Application ranges



With their compact design and pleasant appearance, chain drives from the Gretsch-Unitas group are an ideal solution for the fast, electromotor-driven opening of exhaust air apertures and for room ventilation.

The drives are surface-mounted and perfectly suited to any window type and style thanks to their flat design. Depending on the window profile, the drives can also be installed in a concealed manner.

The extensive range of drives and mounting brackets allows virtually every installation situation and type of mounting. Whether surface-mounted or concealed, they can be used on inward or outward-opening Bottom-Hung, Top-Hung or Side-Hung windows or skylights.

The integrated intelligent technology enables the synchronous control of several chain drives, meaning that even large and heavy window elements can be moved easily.

The combination of chain drives and locking drives offers an added bonus with regard to security and weather protection.

Chain drives

Application ranges

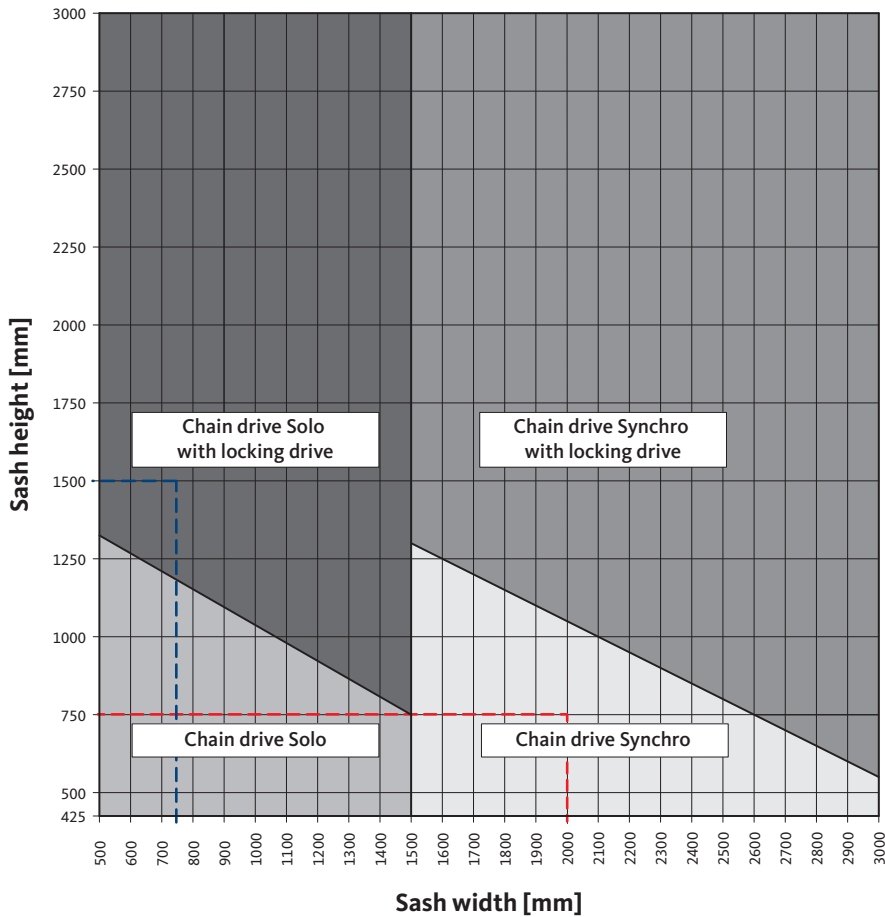

Application ranges

Determination of which drive type to use (Solo/Synchro drive, with or without locking drive) based on the sash width and sash height.

■ **Example 1:**
Bottom-Hung window with the dimensions: 750 x 1500 mm (W x H)
A chain drive Solo with locking drive must be used.

■ **Example 2:**
Bottom-Hung window with the dimensions: 2000 x 750 mm (W x H)
A Synchro chain drive must be used.

All values are reference values which may vary depending on the profile used and the height of the building.
The permissible edge length and the maximum window size must be coordinated with the system provider or the window fabricator.
The instructions of the particular profile system, hardware and glass manufacturers must be observed.
The maximum length of unmounted profile jambs is 1500 mm.

Chain drive KS2

Product characteristics



24V

230V



Product characteristics

- For controlled natural ventilation, SHEV and NSHEV according to EN 12101-2
- High-quality side-flexing chain made of stainless steel
 - without projecting rivet heads
 - straightforward connection to a chain holding fixture
 - small bending radii allow large opening angle with low sash height
- Programmable parameters of the intelligent S12 control electronics*
 - Synchronised multiple operation and sequential control
 - Soft start and soft stop at the end positions
 - Travel, closing force, speed
 - Reversing in the event of overload cut-off during the closing operation
- Suitable for concealed installation in frame profiles
- Fixed mounting of drive on frame without mounting brackets
- Suitable for operation with M-COM for automatic configuration of synchronous running and sequential controls
- TWIN version: with two chains and twice the force
- Version Z: programmable checkback signal for "OPEN" or "CLOSED" end position (max. 24 V, 500 mA)
- Aluminium body anodised or in RAL colours as option

- For information on protection class SK3 see page 459 (risk assessment for power-operated windows in accordance with Machine Directive 2006/42/EC)
- In addition to the drive system, Bottom-Hung sashes must be equipped with restrictor stays (see pages 226–227)

*For programming of S12 control electronics see page 229.

Chain drive KS2

Technical data



24V

230V

Technical data

Specification	24 V DC		230 V AC	
	KS2 S12 24V DC R KS2 S12 24V DC L	KS2 TWIN S12 24V DC	KS2 S12 230V AC R KS2 S12 230V AC L	KS2 S12 230V AC Tandem
Nominal voltage	24 V DC (19 V ... 28 V)	24 V DC (19 V ... 28 V)	230 V AC (50 Hz)	230 V AC (50 Hz)
Nominal current	0.7 A	1.4 A	0.13 A	0.15 A
Breaking current	1.0 A	2.0 A	0.2 A	0.2 A
Nominal power	17 W	34 W	30 W	35 W
Duty ratio	5 cycles (ED 30% - ON: 3 min. / OFF: 7 min.)			
Protection code	IP32			
Ambient temperature	-5 °C to +60 °C			
Max. locking force	1800 N [1]	2 x 1800 N [1]	1800 N [1]	1800 N [1]
Connecting cable	halogen-free, grey 3 x 0.5 mm ² , ~ 3 m 5 x 0.5 mm ² , ~ 3 m (Z version)	halogen-free, grey 3 x 0.5 mm ² , ~ 3 m 5 x 0.5 mm ² , ~ 3 m (Z version)	halogen-free, grey 6 x 0.75 mm ² , ~ 3 m	Master: halogen-free, grey 6 x 0.75 mm ² , ~ 3 m 3 x 0.5 mm ² , ~ 3 m Slave: halogen-free, grey 3 x 0.5 mm ² , ~ 3 m
Speed	Travel ≤ 400 OPEN: 8.0 mm/s CLOSED: 8.0 mm/s	Travel ≤ 400 OPEN: 8.0 mm/s CLOSED: 8.0 mm/s	OPEN: 8.0 mm/s CLOSED: 8.0 mm/s	OPEN: 8.0 mm/s CLOSED: 8.0 mm/s
	Travel > 400 to 600 OPEN: 12.0 mm/s CLOSED: 8.0 mm/s	Travel > 400 to 600 OPEN: 12.0 mm/s CLOSED: 8.0 mm/s		
	Travel > 600 OPEN: 13.5 mm/s CLOSED: 8.0 mm/s			
Max. travel	1000 mm	600 mm	1000 mm	1000 mm
Total length	see order information			
Emission sound pressure level	≤ 70 dB (A)			

[1] depends on fixing

Pulling force + thrust with reference to travel

KS2 S12 24V DC R | KS2 S12 24V DC L

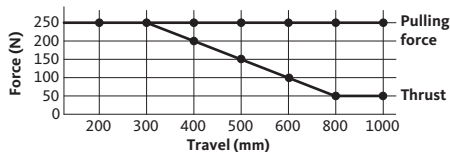

Travel > 600 mm only for tensile load

KS2 S12 230V AC R | KS2 S12 230V AC L

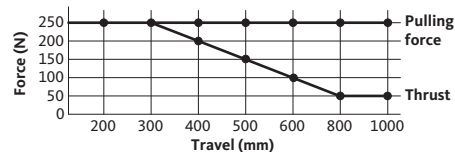

Travel > 600 mm only for tensile load

KS2 TWIN S12 24V DC

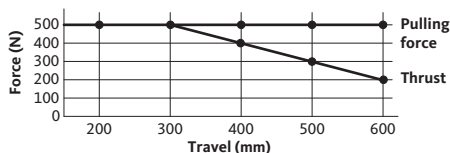

Travel > 600 mm only for tensile load

KS2 S12 230V AC Tandem

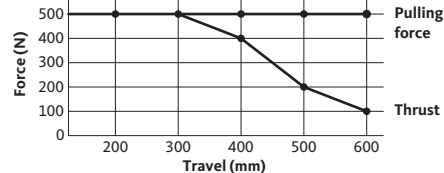

Travel > 600 mm only for tensile load

Chain drive KS2

Order information – version KS2 S12 24V DC R



24V

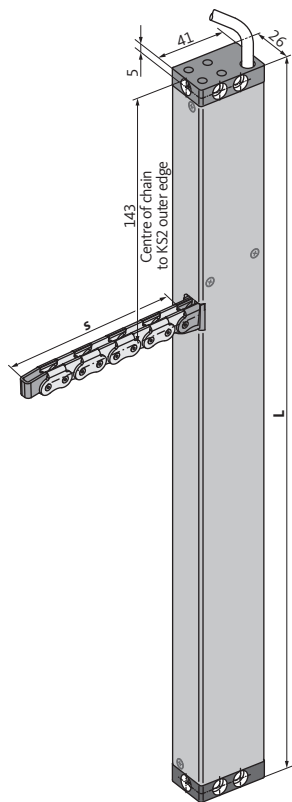





Order information

Specification	KS2 S12 24V DC R				
	Travel [s]	Length [L]	Finish*	PU	Order number
KS2 200 S12 24V R	200 mm	335 mm	EV1	1 pc	521620 
KS2 300 S12 24V R	300 mm	380 mm	EV1	1 pc	521630 
KS2 400 S12 24V R	400 mm	430 mm	EV1	1 pc	521640 
KS2 500 S12 24V R	500 mm	545 mm	EV1	1 pc	521650 
KS2 600 S12 24V R	600 mm	545 mm	EV1	1 pc	521660 
KS2 800 S12 24V R	800 mm	625 mm	EV1	1 pc	521680 
Specification	KS2 S12 24V DC R Z version				
	Travel [s]	Length [L]	Finish*	PU	Order number
KS2 200 S12 24V Z R	200 mm	335 mm	EV1	1 pc	521623 
KS2 300 S12 24V Z R	300 mm	380 mm	EV1	1 pc	521633 
KS2 400 S12 24V Z R	400 mm	430 mm	EV1	1 pc	521643 
KS2 500 S12 24V Z R	500 mm	545 mm	EV1	1 pc	521653 
KS2 600 S12 24V Z R	600 mm	545 mm	EV1	1 pc	521663 
KS2 800 S12 24V Z R	800 mm	625 mm	EV1	1 pc	521683 

*Drive housing painted in special colour (RAL colour) see page 228.

Special cable lengths

Standard connecting cable length extended to:	Order number
5 m – halogen-free, grey – 3 x 0.5 mm ²	501034 
10 m – halogen-free, grey – 3 x 0.5 mm ²	501036 
5 m – halogen-free, grey – 5 x 0.5 mm ²	501054 
10 m – halogen-free, grey – 5 x 0.5 mm ²	501056 

Optional accessories

Specification	PU	Order number
M-COM configuration module for interconnected drive systems	1 pc	524177 

Chain drive KS2







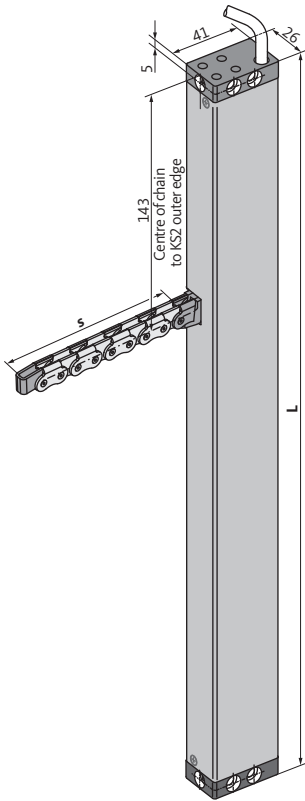





Order information – version KS2 S12 24V DC L



24V





Order information

Specification	KS2 S12 24V DC L				
	Travel [s]	Length [L]	Finish*	PU	Order number
KS2 200 S12 24V L	200 mm	335 mm	EV1	1 pc	521720 
KS2 300 S12 24V L	300 mm	380 mm	EV1	1 pc	521730 
KS2 400 S12 24V L	400 mm	430 mm	EV1	1 pc	521740 
KS2 500 S12 24V L	500 mm	545 mm	EV1	1 pc	521750 
KS2 600 S12 24V L	600 mm	545 mm	EV1	1 pc	521760 
KS2 800 S12 24V L	800 mm	625 mm	EV1	1 pc	521780 
Specification	KS2 S12 24V DC L Z version				
	Travel [s]	Length [L]	Finish*	PU	Order number
KS2 200 S12 24V Z L	200 mm	335 mm	EV1	1 pc	521723 
KS2 300 S12 24V Z L	300 mm	380 mm	EV1	1 pc	521733 
KS2 400 S12 24V Z L	400 mm	430 mm	EV1	1 pc	521743 
KS2 500 S12 24V Z L	500 mm	545 mm	EV1	1 pc	521753 
KS2 600 S12 24V Z L	600 mm	545 mm	EV1	1 pc	521763 
KS2 800 S12 24V Z L	800 mm	625 mm	EV1	1 pc	521783 

*Drive housing painted in special colour (RAL colour) see page 228.

Special cable lengths

Standard connecting cable length extended to:	Order number
5 m – halogen-free, grey – 3 x 0.5 mm ²	for version KS2 S12 24V DC L 501034 
10 m – halogen-free, grey – 3 x 0.5 mm ²	
5 m – halogen-free, grey – 5 x 0.5 mm ²	for version KS2 S12 24V DC L Z version 501054 
10 m – halogen-free, grey – 5 x 0.5 mm ²	

Optional accessories

Specification	PU	Order number
M-COM configuration module for interconnected drive systems	1 pc	524177 

Chain drive KS2

Order information – version KS2 TWIN S12 24V DC



24V

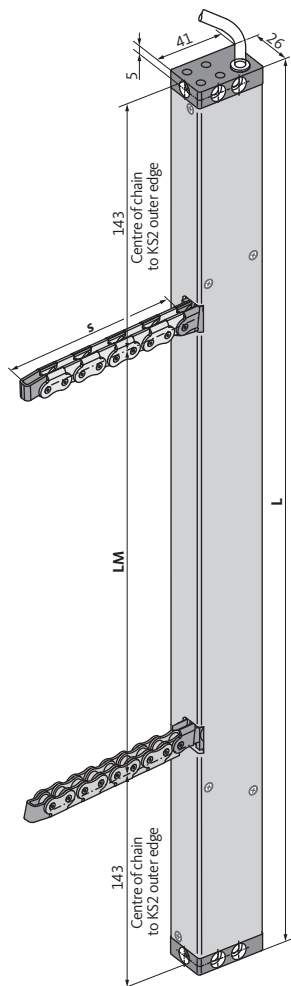

Order information

Specification KS2 TWIN	KS2 TWIN S12 24V DC						Order number
	Travel [s]	Length [L]	Chain-clearance [LM]	Finish*	PU		
200 S12 24V	200 mm	640 mm	354 mm	EV1	1 pc	521820	
400 S12 24V	400 mm	830 mm	544 mm	EV1	1 pc	521840	
500 S12 24V	500 mm	1060 mm	774 mm	EV1	1 pc	521850	
600 S12 24V	600 mm	1060 mm	774 mm	EV1	1 pc	521860	
Specification KS2 TWIN	KS2 TWIN S12 24V DC Z version						Order number
	Travel [s]	Length [L]	Chain-clearance [LM]	Finish*	PU		
200 S12 24V Z	200 mm	640 mm	354 mm	EV1	1 pc	521823	
400 S12 24V Z	400 mm	830 mm	544 mm	EV1	1 pc	521843	
500 S12 24V Z	500 mm	1060 mm	774 mm	EV1	1 pc	521853	
600 S12 24V Z	600 mm	1060 mm	774 mm	EV1	1 pc	521863	

*Drive housing painted in special colour (RAL colour) see page 228.

Special cable lengths

Standard connecting cable length extended to:		Order number	
5 m – halogen-free, grey – 3 x 0.5 mm ²	for version KS2 TWIN S12 24V DC	501034	
10 m – halogen-free, grey – 3 x 0.5 mm ²		501036	
5 m – halogen-free, grey – 5 x 0.5 mm ²	for version KS2 TWIN S12 24V DC Z version	501054	
10 m – halogen-free, grey – 5 x 0.5 mm ²		501056	

Optional accessories

Specification	PU	Order number
M-COM configuration module for interconnected drive systems	1 pc	524177



Chain drive KS2







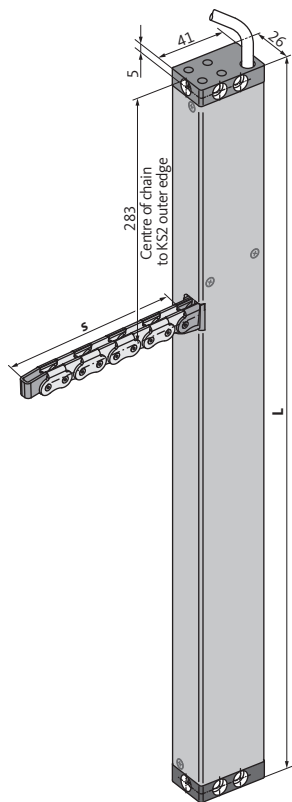



Order information – version KS2 S12 230V AC R



230V





Order information

Specification	KS2 S12 230V AC R				
	Travel [s]	Length [L]	Finish*	PU	Order number
KS2 200 S12 230V R	200 mm	475 mm	EV1	1 pc	494020 
KS2 300 S12 230V R	300 mm	520 mm	EV1	1 pc	494030 
KS2 400 S12 230V R	400 mm	570 mm	EV1	1 pc	494040 
KS2 500 S12 230V R	500 mm	685 mm	EV1	1 pc	494050 
KS2 600 S12 230V R	600 mm	685 mm	EV1	1 pc	494060 
KS2 800 S12 230V R	800 mm	765 mm	EV1	1 pc	494080 
Specification	KS2 S12 230V AC R Z version				
	Travel [s]	Length [L]	Finish*	PU	Order number
KS2 200 S12 230V Z R	200 mm	475 mm	EV1	1 pc	494023 
KS2 300 S12 230V Z R	300 mm	520 mm	EV1	1 pc	494033 
KS2 400 S12 230V Z R	400 mm	570 mm	EV1	1 pc	494043 
KS2 500 S12 230V Z R	500 mm	685 mm	EV1	1 pc	494053 
KS2 600 S12 230V Z R	600 mm	685 mm	EV1	1 pc	494063 
KS2 800 S12 230V Z R	800 mm	765 mm	EV1	1 pc	494083 

*Drive housing painted in special colour (RAL colour) see page 228.

Special cable lengths

Standard connecting cable length extended to:	Order number	
5 m – halogen-free, grey – 6 x 0.75 mm ²	501164	
10 m – halogen-free, grey – 6 x 0.75 mm ²	501166	

Chain drive KS2







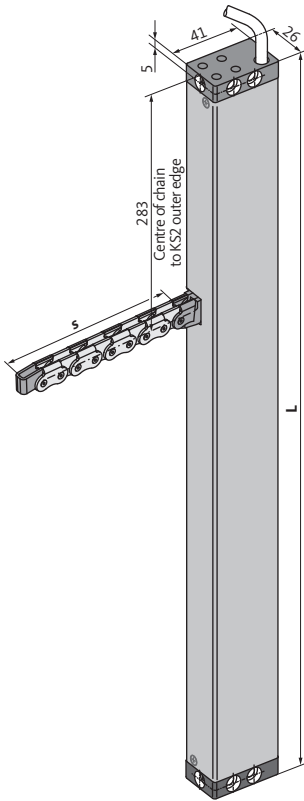





Order information – version KS2 S12 230V AC L



230V





Order information

Specification	KS2 S12 230V AC L				
	Travel [s]	Length [L]	Finish*	PU	Order number
KS2 200 S12 230V L	200 mm	475 mm	EV1	1 pc	494120 
KS2 300 S12 230V L	300 mm	520 mm	EV1	1 pc	494130 
KS2 400 S12 230V L	400 mm	570 mm	EV1	1 pc	494140 
KS2 500 S12 230V L	500 mm	685 mm	EV1	1 pc	494150 
KS2 600 S12 230V L	600 mm	685 mm	EV1	1 pc	494160 
KS2 800 S12 230V L	800 mm	765 mm	EV1	1 pc	494180 
Specification	KS2 S12 230V AC L Z version				
	Travel [s]	Length [L]	Finish*	PU	Order number
KS2 200 S12 230V Z L	200 mm	475 mm	EV1	1 pc	494123 
KS2 300 S12 230V Z L	300 mm	520 mm	EV1	1 pc	494133 
KS2 400 S12 230V Z L	400 mm	570 mm	EV1	1 pc	494143 
KS2 500 S12 230V Z L	500 mm	685 mm	EV1	1 pc	494153 
KS2 600 S12 230V Z L	600 mm	685 mm	EV1	1 pc	494163 
KS2 800 S12 230V Z L	800 mm	765 mm	EV1	1 pc	494183 

*Drive housing painted in special colour (RAL colour) see page 228.

Special cable lengths

Standard connecting cable length extended to:	Order number	
5 m – halogen-free, grey – 6 x 0.75 mm ²	501164	
10 m – halogen-free, grey – 6 x 0.75 mm ²	501166	

Chain drive KS2

Order information – version KS2 S12 230V AC Tandem-Set



230V

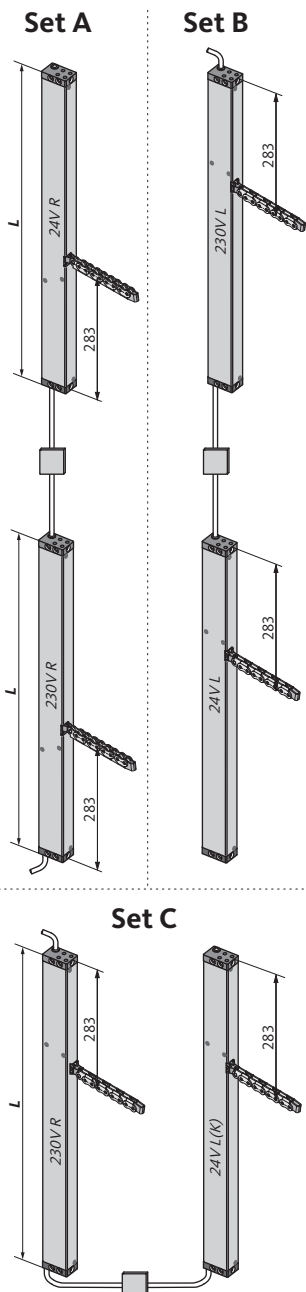

Order information

Specification KS2 Tandem-Set A (R/R)	KS2 S12 230V AC Tandem-Set A				
	Travel [s]	Length [L]	Finish*	PU	Order number
200 S12 230V	200 mm	475 mm	EV1	1 pc	494220 
300 S12 230V	300 mm	520 mm	EV1	1 pc	494230 
400 S12 230V	400 mm	570 mm	EV1	1 pc	494240 
500 S12 230V	500 mm	685 mm	EV1	1 pc	494250 
600 S12 230V	600 mm	685 mm	EV1	1 pc	494260 
800 S12 230V	800 mm	765 mm	EV1	1 pc	494280 
Specification KS2 Tandem-Set B (L/L)	KS2 S12 230V AC Tandem-Set B				
	Travel [s]	Length [L]	Colour*	PU	Order number
200 S12 230V	200 mm	475 mm	EV1	1 pc	494320 
300 S12 230V	300 mm	520 mm	EV1	1 pc	494330 
400 S12 230V	400 mm	570 mm	EV1	1 pc	494340 
500 S12 230V	500 mm	685 mm	EV1	1 pc	494350 
600 S12 230V	600 mm	685 mm	EV1	1 pc	494360 
800 S12 230V	800 mm	765 mm	EV1	1 pc	494380 
Specification KS2 Tandem-Set C (R/L-K)	KS2 S12 230V AC Tandem-Set C				
	Travel [s]	Length [L]	Colour*	PU	Order number
200 S12 230V	200 mm	475 mm	EV1	1 pc	494420 
300 S12 230V	300 mm	520 mm	EV1	1 pc	494430 
400 S12 230V	400 mm	570 mm	EV1	1 pc	494440 
500 S12 230V	500 mm	685 mm	EV1	1 pc	494450 
600 S12 230V	600 mm	685 mm	EV1	1 pc	494460 
800 S12 230V	800 mm	765 mm	EV1	1 pc	494480 

*Drive housing painted in special colour (RAL colour) see page 228.

Chain drive KS2

Order information – version KS2 S12 230V AC Tandem-Set



230V

Special cable lengths

Standard connecting cable length extended to:	Order number	
5 m – halogen-free, grey – 6 x 0.75 mm ²	501164	
10 m – halogen-free, grey – 6 x 0.75 mm ²	501166	
5 m – halogen-free, grey – 3 x 0.5 mm ²	501034	
10 m – halogen-free, grey – 3 x 0.5 mm ²	501036	

Chain drive KS2

Fixings – overview



Overview of fixings

Example of application				1	2	3	4	5	
Mounting bracket				K94	-	K96-1	-	K105A K105B K106	
Chain holding fixture				F41 F17		F42 F95	F42 F95	F18 F19 F20	
Space requirement		min.	[mm]	16 – 30	25 – 30	38	30	Observe profile depth	
Overlap thickness [1]			[mm]	0 – 21	0 – 21	0 – 21	0 – 21	Observe profile depth	
Opening angle [2]		max.	[DEG]	35	45	60	40	60	
Sash weight [3]		max.	[kg]	70	60	50	70	70	
Sash material		Aluminium		■	■	■	■	■	
		Timber		■	■	■	■	●	
		PVC		■	■	■	■	-	
Sash and assembly type	Bottom-Hung	inward	MCE	SI	■	■	-	-	-
				FI	-	-	■	■	-
			SCE	SI	■	■	-	-	-
			FI	-	-	■	■	-	
		outward	MCE	FI	■	■	-	-	-
				SI	-	-	-	-	-
	SCE		FI	■	■	-	-	-	
		SI	-	-	-	-	-		
	Side-Hung	inward	MCE	SI	■	■	-	-	-
				FI	-	-	■	■	-
			SCE	SI	-	-	-	-	-
			FI	-	-	-	-	-	
		outward	MCE	FI	■	■	-	-	-
				SI	-	-	-	-	-
SCE	FI		■	■	-	-	-		
	SI	-	-	-	-	-			
Parallel-Projecting / Projecting / Top-Hung	outward		FI	■	■	-	-	■	
Profile installation				-	-	-	-	■	
ESW [4]		Solo [mm]		600 – 1200					
		Sync2 [mm]		1000 – 2500					
ESH [4]		Solo [mm]		250 – 1500					
		Sync2 [mm]		250 – 2500					

■ suitable | ● less suitable

[1] Sash dimensions and opening angle may deviate.

[2] Guide value for opening angle calculated for min. ESW/ESH for inward-opening sash with drives mounted on MCE.

Different opening angles will be obtained for other sash heights, for outward-opening sashes and for sashes with drives mounted on the SCE.

[3] Observe attack points of the drives! Guide value for max. sash weight applies for solo drive on Bottom-Hung sash with max. opening angle.

[4] The instructions of the particular profile system, hardware and glass manufacturers must be observed. The specifications for ESW/ESH apply accordingly for Side-Hung sashes.

Chain drive KS2

Fixings – application examples



Application examples

1	2	2
Installation on Bottom-Hung sash, inwards Shown on aluminium window	Installation on Bottom-Hung sash, inwards Shown on timber window	Frame installation, Top-Hung sash, outward Shown on aluminium window
3	4	4
Frame installation, inward-opening Bottom-Hung sash Shown on steel window	Frame installation, inward-opening Bottom-Hung sash Shown on aluminium window	Frame installation, inward-opening Bottom-Hung sash Shown on aluminium window
5		
Profile installation, inward-opening Bottom-Hung sash Shown on aluminium profile		

Chain drive KS2

Fixings – chain holding fixtures – surface-mounted installation

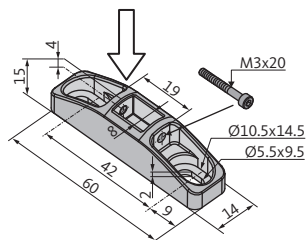

Attach chain in direction of arrow

Chain holding fixture F41

Application

- Surface-mounted installation on sashes and frames of the main and secondary closing edge of inward/outward-opening windows
- For surface-mounted chain drives KS2

Finish*	PU	Order number
Die-cast aluminium, gloss chrome-plated	1 pc	151440 
Contents: 1 x chain holding fixture, 1 x M3x20 screw, 1 x drilling template		

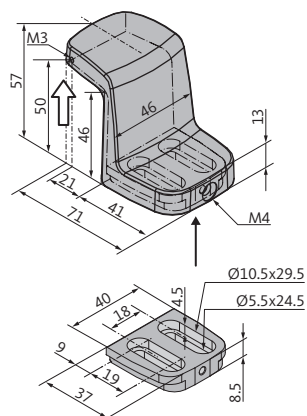

Attach chain in direction of arrow

Chain holding fixture F42

Application

- Surface-mounted installation on sashes of inward-opening windows
- For surface-mounted chain drives KS2

Finish*	PU	Order number
Die-cast aluminium, gloss chrome-plated	1 pc	151441 
Contents: 1 x chain holding fixture, 1 x base plate, 1 x M4x10 countersunk screw, 1 x M3x25 screw, 1 x drilling template		

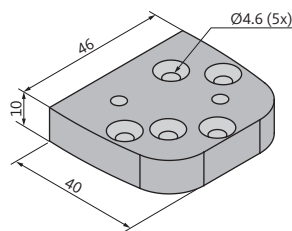

Packer for chain holding fixture F42

Application

- As compensating plate when installed on timber and PVC windows

Finish*	PU	Order number
Aluminium (EV1)	1 pc	523961 

*Chain holding fixtures painted/powder-coated in special colour (RAL colour) see page 228.

Chain drive KS2

Fixings – chain holding fixtures – surface-mounted installation

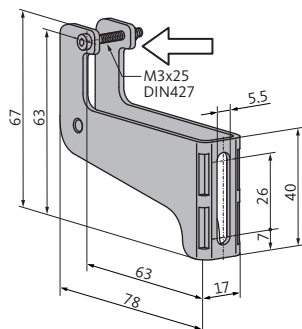

Attach chain in direction of arrow

Chain holding fixture F95

Application

- Surface-mounted installation on sashes of inward-opening windows
- For surface-mounted chain drives KS2
- In combination with mounting bracket K96-1

Finish*	PU	Order number	
Stainless steel	1 pc	523972	
Contents: 1 x chain holding fixture, 1 x M3x25 screw, 1 x M3 nut			

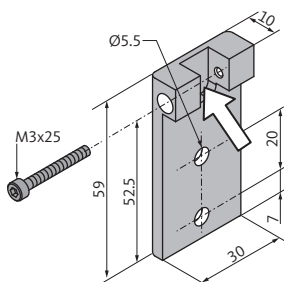

Attach chain in direction of arrow

Chain holding fixture F19

Application

- Surface-mounted installation on the active sashes of inward-opening windows
- For KS2 chain drives concealed in the frame
- In combination with mounting bracket K105

Finish*	PU	Order number	
Aluminium (EV1)	1 pc	151419	
Contents: 1 x chain holding fixture, 1 x M3x25 cheese-head screw			

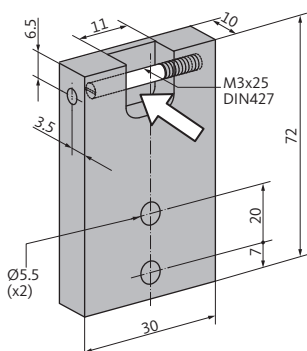

Attach chain in direction of arrow

Chain holding fixture F20

Application

- Surface-mounted installation on the active sashes of inward-opening windows
- For KS2 chain drives concealed in the frame
- In combination with mounting bracket K105

Finish*	PU	Order number	
Aluminium (EV1)	1 pc	151420	
Contents: 1 x chain holding fixture, 1 x M3x25 setscrew, 2 x M5x20 lens screw			

*Chain holding fixtures painted/powder-coated in special colour (RAL colour) see page 228.

Chain drive KS2

Fixings – chain holding fixtures – concealed installation

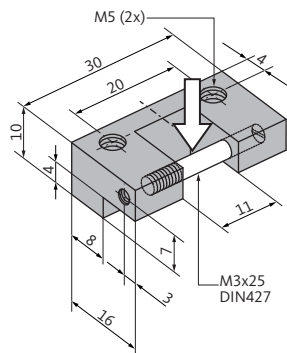

Attach chain in direction of arrow

Chain holding fixture F17

Application

- Concealed installation on flush or active sashes of inward/outward-opening windows
- Fastened on rebate side below impact gasket with screws which can be removed from the outside
- For KS2 chain drives concealed in the frame
- In combination with mounting bracket K105

Finish*	PU	Order number
Aluminium (EV1)	1 pc	151417 
Contents: 1 x chain holding fixture, 1 x M3x25 setscrew, 2 x M5x10 lens screw		

*Chain holding fixtures painted/powder-coated in special colour (RAL colour) see page 228.

Chain drive KS2

Fixings – chain holding fixtures – partially-concealed installation

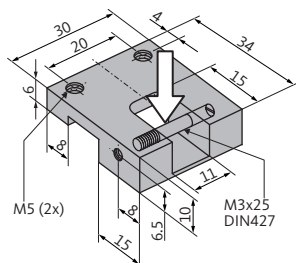

Attach chain in direction of arrow

Chain holding fixture F18

Application

- Partially-concealed installation on the inside of the profile of inward-opening window sashes
- Fastened below impact gasket with screws which can be removed from the outside
- For KS2 chain drives concealed in the frame
- In combination with mounting bracket K105

Finish*	PU	Order number	
Aluminium (EV1)	1 pc	151418	
Contents: 1 x chain holding fixture, 1 x M3x25 setscrew, 2 x M5x10 lens screw			

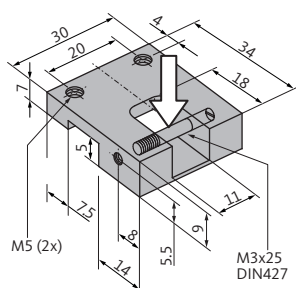

Attach chain in direction of arrow

Chain holding fixture F18-1

Application

- Partially-concealed installation on the inside of the profile of inward-opening window sashes
- Fastened below impact gasket with screws which can be removed from the outside
- For KS2 chain drives concealed in the frame
- In combination with mounting bracket K105

Finish*	PU	Order number	
Aluminium (EV1)	1 pc	151428	
Contents: 1 x chain holding fixture, 1 x M3x25 setscrew, 2 x M5x10 lens screw			

*Chain holding fixtures painted/powder-coated in special colour (RAL colour) see page 228.

Chain drive KS2

Fixings – mounting brackets – surface-mounted/concealed installation

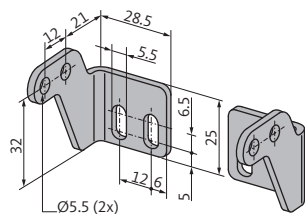

Mounting bracket K94

Application

- Surface-mounted installation on sashes and frames of inward/outward-opening windows
- For fixed or swivel-mounted attachment of KS2 chain drives
- In combination with chain holding fixture F41

Finish*	PU	Order number
Stainless steel	1 pc	523921 
Contents: 2 x mounting bracket, 4 x M5x10 Torx screw, 4 x washer A 5.3, 2 x M5x16 Torx screw		

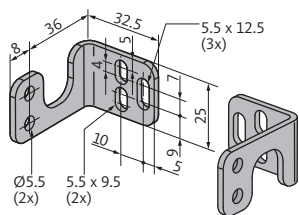

Mounting bracket K96-1

Application

- Surface-mounted installation on frames of inward-opening windows
- For fixed or swivel-mounted attachment of KS2 chain drives
- In combination with chain holding fixture F95

Finish*	PU	Order number
Stainless steel	1 pc	523997 
Contents: 2 x mounting bracket, 4 x M5x10 Torx screw, 2 x M5x16 Torx screw		

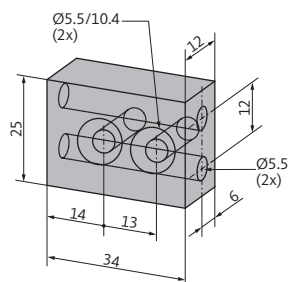

Mounting bracket K105-A

Application

- Concealed installation in frame profiles of inward/outward-opening windows
- For fixed attachment of concealed KS2 chain drives
- In combination with chain holding fixture F17
- Exterior sash height min 700 mm

Finish*	PU	Order number
Aluminium (EV1)	1 pc	523975 
Contents: 2 x mounting bracket		

*Mounting brackets painted/powder-coated in special colour (RAL colour) see page 228.

Chain drive KS2

Fixings – mounting brackets – concealed installation

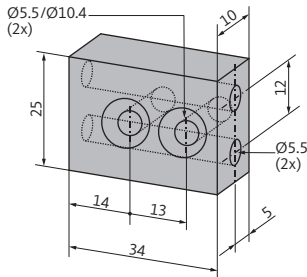

Mounting bracket K105-A-W77

Application

- Concealed installation in frame profiles of inward/outward-opening windows
- For fixed attachment of concealed KS2 chain drives
- In combination with chain holding fixture F18-1
- Exterior sash height min 400 mm

Finish*	PU	Order number	
Aluminium (EV1)	1 pc	523965	
Contents: 2 x mounting bracket			

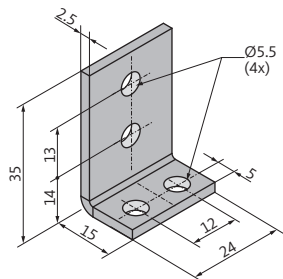

Mounting bracket K105-B

Application

- Concealed installation in frame profiles of inward/outward-opening windows
- For fixed attachment of concealed KS2 chain drives
- In combination with chain holding fixtures F17, F18, F19, F20

Finish*	PU	Order number	
Stainless steel	1 pc	523977	
Contents: 2 x mounting bracket, 4 x M5x10 lens screw, 4 x washer A 5.3			

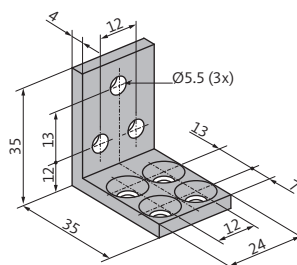

Mounting bracket K106

Application

- Concealed installation in frame profiles of inward/outward-opening windows
- For fixed attachment of concealed KS2 chain drives
- In combination with chain holding fixture F19, F20
- External sash height min. 700 mm (F19), min. 500 mm (F20)

Finish*	PU	Order number	
Aluminium (EV1)	1 pc	523976	
Contents: 2 x mounting bracket, 4 x M5x10 countersunk-head screw			

*Mounting brackets painted/powder-coated in special colour (RAL colour) see page 228.

Chain drive KS4

Product characteristics



24V



Product characteristics

- For controlled natural ventilation, SHEV and NSHEV according to EN 12101-2
- High-quality side-flexing chain made of stainless steel
 - without projecting rivet heads
 - straightforward connection to a chain holding fixture
 - small bending radii allow large opening angle with low sash height
- Programmable parameters of the intelligent S12 control electronics*
 - Checkback signal for "OPEN" end position (max. 24 V, 500 mA)
 - Synchronised multiple operation and sequential control
 - Soft start and soft stop at the end positions
 - Travel, closing force, speed
 - Reversing in the event of overload cut-off during the closing operation
- Suitable for concealed installation in frame profiles
- Fixed mounting of drive on frame without mounting brackets
- Checkback signal for "CLOSED" end position (max. 24 V, 500 mA)
- Cable routing integrated into the body with pluggable connector at both drive ends for the following options
 - Wire Click with connecting cables in various lengths
 - Series connection of several drives in interconnected systems
 - Cable entry from both sides of casing possible
- Compatible with the pluggable configuration module M-COM Click
- Aluminium body anodised or in RAL colours as option

- For information on protection class SK3 see page 459 (risk assessment for power-operated windows in accordance with Machine Directive 2006/42/EC)
- In addition to the drive system, Bottom-Hung sashes must be equipped with restrictor stays (see pages 226–227)

*For programming of S12 control electronics see page 229.

Chain drive KS4

Technical data



24V

Technical data

Specification	24 V DC		
	KS4 S12 24V DC R KS4 S12 24V DC L	KS4 400 S12 24V DC R + L elongated	KS4 Drehvolution
Nominal voltage	24 V DC (19 V ... 28 V)	24 V DC (19 V ... 28 V)	24 V DC (19 V ... 28 V)
Nominal current	0.9 A	0.9 A	0.9 A
Breaking current	1.2 A	1.2 A	1.2 A
Nominal power	22 W	22 W	22 W
Duty ratio	5 cycles (ED 30% - ON: 3 min. / OFF: 7 min.)		
Protection code	IP32		
Ambient temperature	-5 °C to +60 °C		
Max. pulling force	400 N	200 N	400 N
Max. thrust	see diagram	200 N	200 N
Max. locking force	1800 N [1]	1800 N [1]	1800 N [1]
Connecting cable	halogen-free, grey 5 x 0.5 mm ² , ~ 2 m	halogen-free, grey 5 x 0.5 mm ² , ~ 2 m	halogen-free, grey 5 x 0.5 mm ² , ~ 2 m
Speed	Travel ≤ 400 OPEN: 8.0 mm/s CLOSED: 8.0 mm/s	Travel < 400 OPEN: 8.0 mm/s CLOSED: 8.0 mm/s	Travel < 350 OPEN: 8.0 mm/s CLOSED: 8.0 mm/s
	Travel > 400 to 600 OPEN: 12.0 mm/s CLOSED: 8.0 mm/s		
	Travel > 600 OPEN: 13.5 mm/s CLOSED: 8.0 mm/s		
Max. travel	1000 mm	400 mm	350 mm
Total length	see order information	551 mm	551 mm
Monitoring contact	"CLOSED" end position (max. 24 V, 500 mA)		
Emission sound pressure level	≤ 70 dB (A)		

[1] depends on fixing

Pulling force + thrust with reference to travel

KS4 S12 24V DC R | KS4 S12 24V DC L

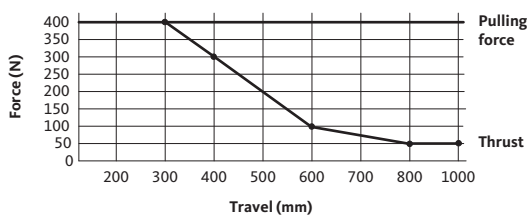

Travel > 600 mm only for tensile load

Chain drive KS4





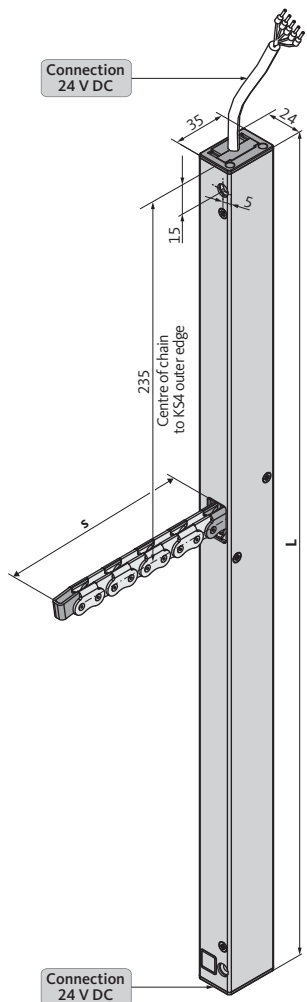

Order information – version KS4 S12 24V DC R



24V





Order information



Specification	KS4 S12 24V DC R				
	Travel [s]	Length [L]	Finish*	PU	Order number
KS4 200 S12 24V R	200 mm	455 mm	EV1	1 pc	522020 
KS4 300 S12 24V R	300 mm	551 mm	EV1	1 pc	522030 
KS4 400 S12 24V R	400 mm	551 mm	EV1	1 pc	522040 
KS4 500 S12 24V R	500 mm	665 mm	EV1	1 pc	522050 
KS4 600 S12 24V R	600 mm	665 mm	EV1	1 pc	522060 
KS4 800 S12 24V R	800 mm	755 mm	EV1	1 pc	522080 
KS4 1000 S12 24V R	1000 mm	868 mm	EV1	1 pc	522000 

*Drive housing painted in special colour (RAL colour) see page 228.

Plug solution

Wire Click	PU	Order number
3 m – halogen-free, grey – 5 x 0.5 mm ²	1 pc	501251 
5 m – halogen-free, grey – 5 x 0.5 mm ²	1 pc	501252 
10 m – halogen-free, grey – 5 x 0.5 mm ²	1 pc	501253 

Optional accessories

Specification	PU	Order number
M-COM Click configuration module for interconnected drive systems	1 pc	524167 
M-COM configuration module for interconnected drive systems	1 pc	524177 

Chain drive KS4





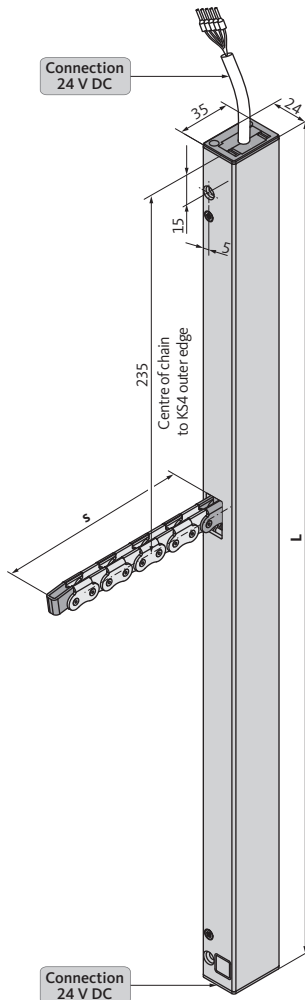

Order information – version KS4 S12 24V DC L



24V





Order information



Specification	KS4 S12 24V DC L				
	Travel [s]	Length [L]	Finish*	PU	Order number
KS4 200 S12 24V L	200 mm	455 mm	EV1	1 pc	520120 
KS4 300 S12 24V L	300 mm	551 mm	EV1	1 pc	520130 
KS4 400 S12 24V L	400 mm	551 mm	EV1	1 pc	520140 
KS4 500 S12 24V L	500 mm	665 mm	EV1	1 pc	520150 
KS4 600 S12 24V L	600 mm	665 mm	EV1	1 pc	520160 
KS4 800 S12 24V L	800 mm	755 mm	EV1	1 pc	520180 
KS4 1000 S12 24V L	1000 mm	868 mm	EV1	1 pc	520100 

*Drive housing painted in special colour (RAL colour) see page 228.

Plug solution

Wire Click	PU	Order number
3 m – halogen-free, grey – 5 x 0.5 mm ²	1 pc	501251 
5 m – halogen-free, grey – 5 x 0.5 mm ²	1 pc	501252 
10 m – halogen-free, grey – 5 x 0.5 mm ²	1 pc	501253 

Optional accessories

Specification	PU	Order number
M-COM Click configuration module for interconnected drive systems	1 pc	524167 
M-COM configuration module for interconnected drive systems	1 pc	524177 

Chain drive KS4

Order information – version KS4 400 S12 24V DC R + L elongated – surface-mounted installation



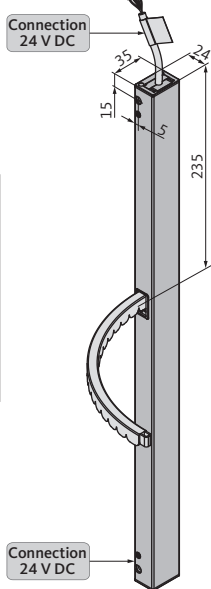

24V

Specification V1



Order information



Specification	KS4 400 S12 24V DC R + L elongated				
	Travel [s]	Length [L]	Finish*	PU	Order number
KS4 400 S12 24V L elongated V1	400 mm	551 mm	EV1	1 pc	522540 
KS4 400 S12 24V R elongated V2	400 mm	551 mm	EV1	1 pc	522440 

*Drive housing painted in special colour (RAL colour) see page 228.

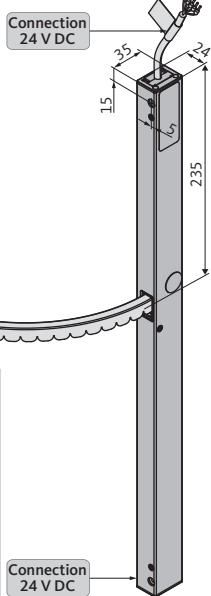

Specification V2



Plug solution

Wire Click	PU	Order number
3 m – halogen-free, grey – 5 x 0.5 mm ²	1 pc	501251 
5 m – halogen-free, grey – 5 x 0.5 mm ²	1 pc	501252 
10 m – halogen-free, grey – 5 x 0.5 mm ²	1 pc	501253 

Optional accessories

Specification	PU	Order number
M-COM Click configuration module for interconnected drive systems	1 pc	524167 
M-COM configuration module for interconnected drive systems	1 pc	524177 

Chain drive KS4

Order information – version KS4 400 S12 24V DC R + L elongated – surface-mounted installation



24V

Face-fixed mounting

Opening angle 90°:
from ESW 170 mm to 250 mm

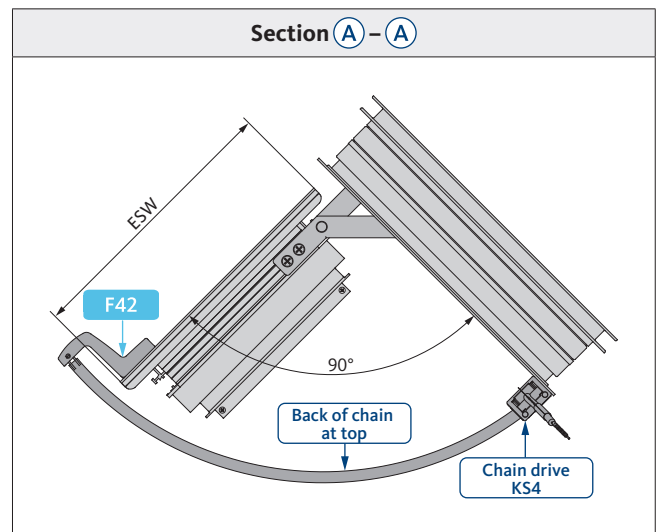
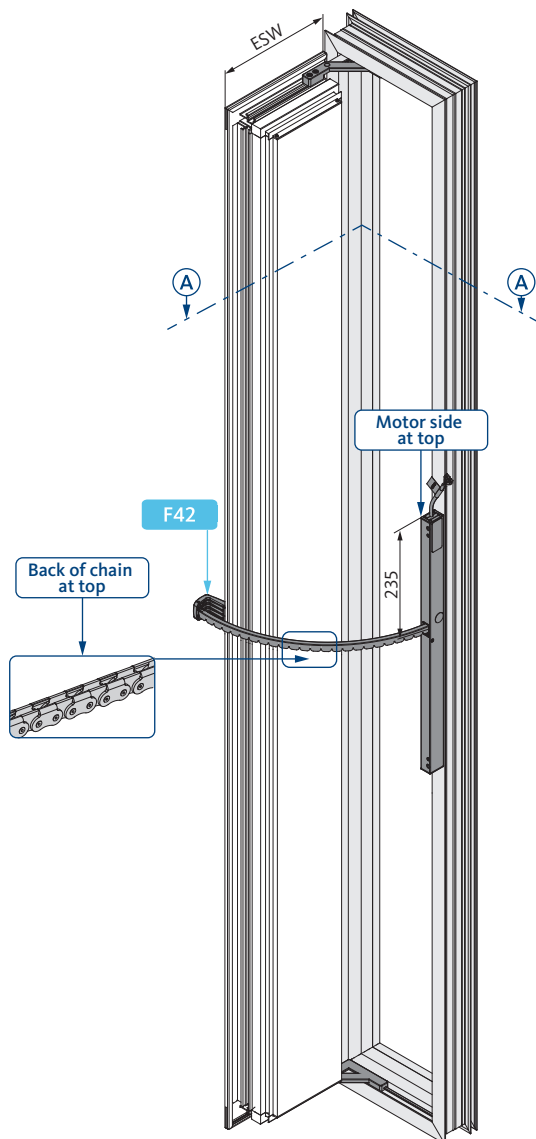

Travel programming

Exterior sash width (ESW)	Travel	Opening angle approx.
170 mm	280 mm	90°
180 mm	305 mm	90°
200 mm	330 mm	90°
225 mm	350 mm	90°
250 mm	375 mm	90°
275 mm	400 mm	85°
300 mm	400 mm	80°

The travel is programmed
 – depending on the required opening angle
 – depending on the exterior sash width

Chain drive KS4

Order information – version KS4 400 S12 24V DC R + L elongated – profile-integrated installation



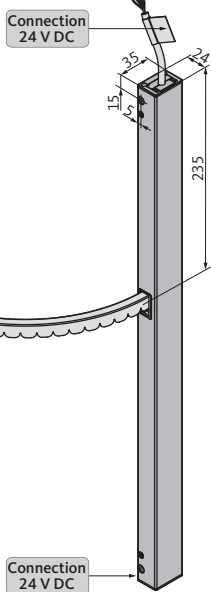

24V

Specification V2



Order information



Specification	KS4 400 S12 24V DC R + L elongated				
	Travel [s]	Length [L]	Finish*	PU	Order number
KS4 400 S12 24V L elongated V2	400 mm	551 mm	EV1	1 pc	522640 
KS4 400 S12 24V R elongated V1	400 mm	551 mm	EV1	1 pc	522340 

*Drive housing painted in special colour (RAL colour) see page 228.

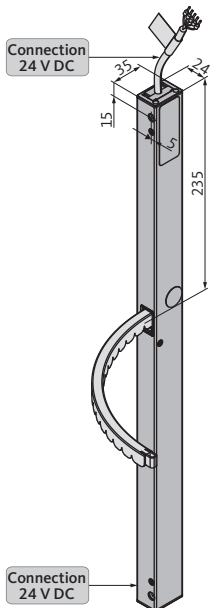

Specification V1



Plug solution

Wire Click	PU	Order number
3 m – halogen-free, grey – 5 x 0.5 mm ²	1 pc	501251 
5 m – halogen-free, grey – 5 x 0.5 mm ²	1 pc	501252 
10 m – halogen-free, grey – 5 x 0.5 mm ²	1 pc	501253 

Optional accessories

Specification	PU	Order number
M-COM Click configuration module for interconnected drive systems	1 pc	524167 
M-COM configuration module for interconnected drive systems	1 pc	524177 

Chain drive KS4

Order information – version KS4 400 S12 24V DC R + L elongated – profile-integrated installation



24V

Profile-integrated assembly

Opening angle 90°:
from ESW 170 mm to 250 mm

Profile-integrated installation can be scheduled on request!

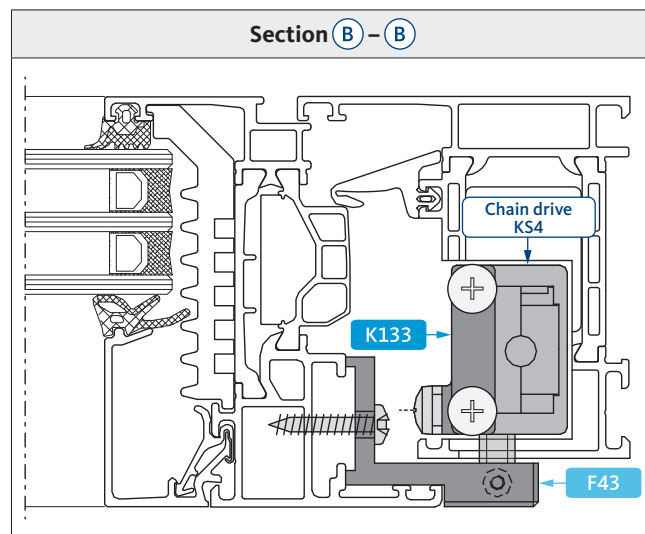
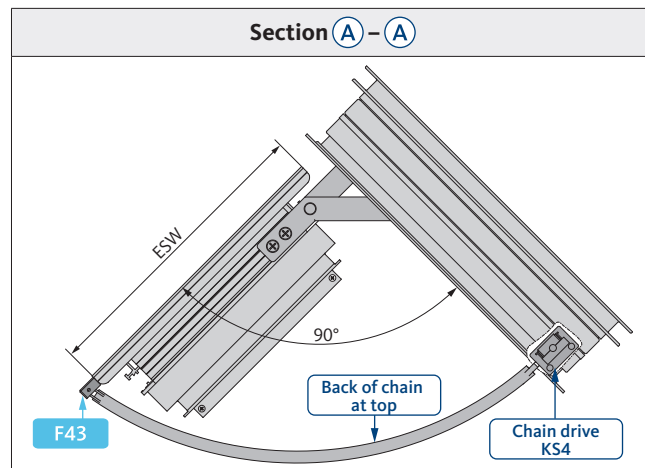
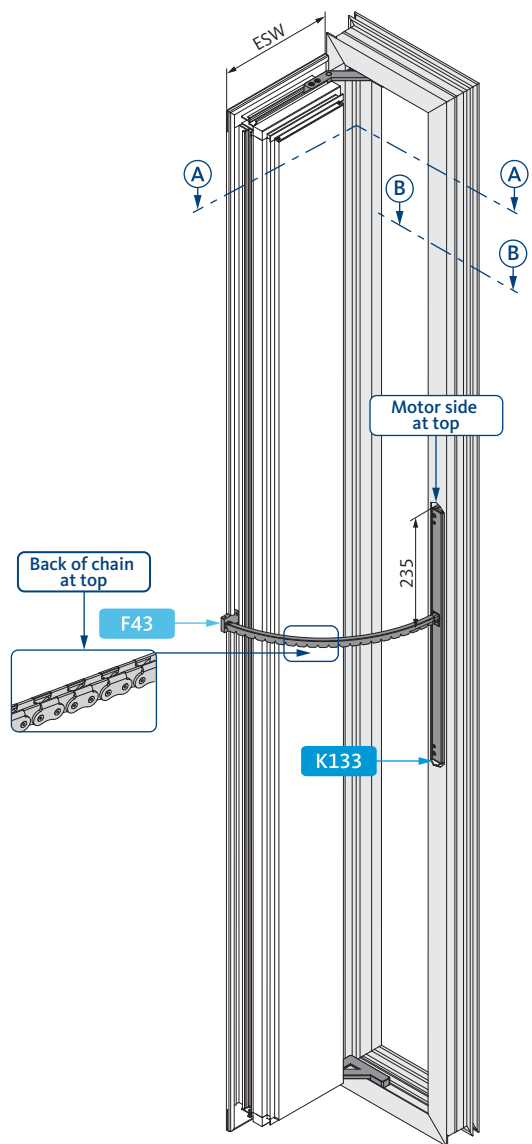

Travel programming

Exterior sash width (ESW)	Travel	Opening angle approx.
170 mm	280 mm	90°
180 mm	305 mm	90°
200 mm	330 mm	90°
225 mm	350 mm	90°
250 mm	375 mm	90°
275 mm	400 mm	85°
300 mm	400 mm	80°

The travel is programmed
– depending on the required opening angle
– depending on the exterior sash width

Chain drive KS4

Order information – version KS4 Drehvolution – Set 1



24V

Drehvolution Set 1 (KS4R and F55R) for DIN left Side-Hung sashes

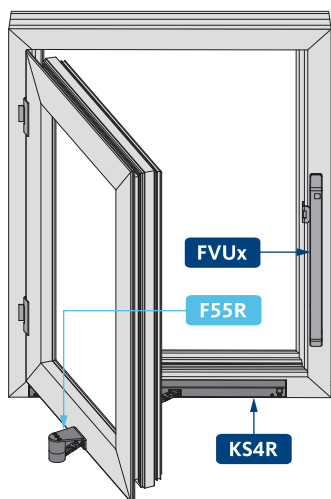

Order information

KS4 Drehvolution – Set 1				
Travel [s]	Length [L]	Finish*	PU	Order number
350 mm	551 mm	EV1	1 pc	522035

*Drive housing painted in special colour (RAL colour) see page 228.

Scope of delivery

1 x chain drive KS4 400 S12 24V DC R
 1 x connecting cable halogen-free, grey 5 x 0.5 mm², ~ 2 m
 1 x chain holding fixture F55R

Drehvolution Set 1 (KS4R and F55R) for DIN right Side-Hung sashes

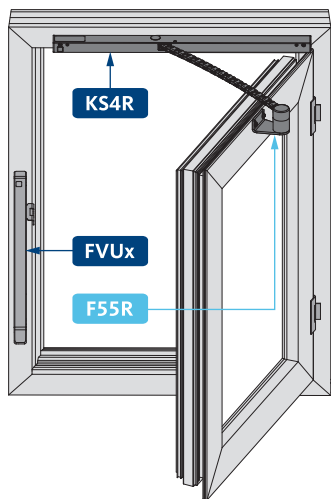

Plug solution

Wire Click	PU	Order number
3 m – halogen-free, grey – 5 x 0.5 mm ²	1 pc	501251
5 m – halogen-free, grey – 5 x 0.5 mm ²	1 pc	501252
10 m – halogen-free, grey – 5 x 0.5 mm ²	1 pc	501253

ESW = up to max. 1200 mm

ESW = up to 1000 mm use 1 x Drehvolution

ESW = from 1001 mm use 2 x Drehvolution Set 1 + Set 2 (synchronous mode)

Space required on frame = 26 mm

The specified window sizes are only recommendations.

A stable Side-Hung sash with additional locking device is required!

ESH = up to max. 2000 mm

ESH = up to 1200 mm use 1 x Drehvolution

ESH = from 1201 mm use 2 x Drehvolution Set 1 + Set 2 (synchronous operation)

Optional accessories

Specification	PU	Order number
M-COM Click configuration module for interconnected drive systems	1 pc	524167
M-COM configuration module for interconnected drive systems	1 pc	524177

Chain drive KS4

Order information – version KS4 Drehvolution – Set 2



24V

Drehvolution Set 2 (KS4L and F55L) for DIN left Side-Hung sashes

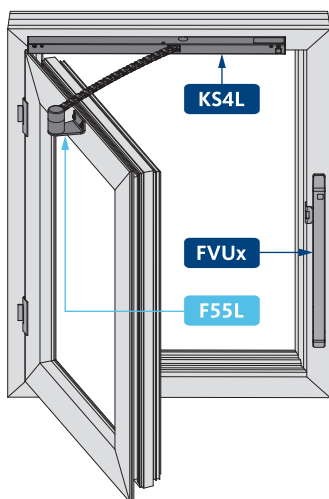

Drehvolution Set 2 (KS4L and F55L) for DIN right Side-Hung sashes

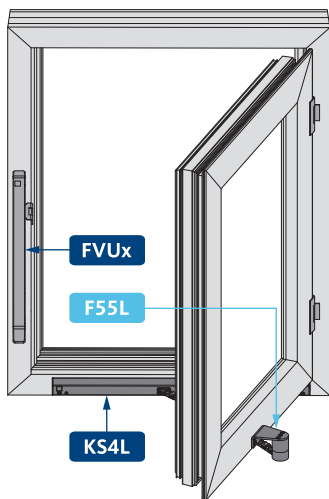

- ESW = up to max. 1200 mm
- ESW = up to 1000 mm use 1 x Drehvolution
- ESW = from 1001 mm use 2 x Drehvolution Set 1 + Set 2 (synchronous mode)

Space required on frame = 26 mm

The specified window sizes are only recommendations.
A stable Side-Hung sash with additional locking device is required!

- ESH = up to max. 2000 mm
- ESH = up to 1200 mm use 1 x Drehvolution
- ESH = from 1201 mm use 2 x Drehvolution Set 1 + Set 2 (synchronous operation)

Order information

KS4 Drehvolution – Set 2				
Travel [s]	Length [L]	Finish*	PU	Order number
350 mm	551 mm	EV1	1 pc	520035

*Drive housing painted in special colour (RAL colour) see page 228.

Scope of delivery

- 1 x chain drive KS4 400 S12 24V DC L
- 1 x connecting cable halogen-free, grey 5 x 0.5 mm², ~ 2 m
- 1 x chain holding fixture F55L

Plug solution

Wire Click	PU	Order number
3 m – halogen-free, grey – 5 x 0.5 mm ²	1 pc	501251
5 m – halogen-free, grey – 5 x 0.5 mm ²	1 pc	501252
10 m – halogen-free, grey – 5 x 0.5 mm ²	1 pc	501253

Optional accessories

Specification	PU	Order number
M-COM Click configuration module for interconnected drive systems	1 pc	524167
M-COM configuration module for interconnected drive systems	1 pc	524177

Chain drive KS4

Fixings – overview



Overview of fixings

Example of application					1	2	3	4	5
Mounting bracket					K134	K132	-	K133	K135
Chain holding fixture					F41	F42	F42	F43	F19
Space requirement		min.	[mm]		20	28	27	-	-
Overlap thickness [1]			[mm]		0 – 21	5 – 21	0 – 21	-	-
Opening angle [2]		max.	[DEG]		45	60	40	-	-
Sash weight [3]		max.	[kg]		85	70	85	-	-
Sash material		Aluminium			■	■	■	■	■
		Timber			■	■	■	■	■
		PVC			■	■	■	■	■
Sash and assembly type	Bottom-Hung	inward	MCE	SI	■	■	-	-	-
				FI	-	-	■	-	-
			SCE	SI	■	■	-	-	-
		FI		-	-	■	-	-	
		outward	MCE	FI	■	■	-	-	-
				SI	-	-	-	-	-
	SCE		FI	■	■	-	-	-	
		SI	-	-	-	-	-		
	Top-Hung	inward	MCE	SI	●	●	-	-	-
				FI	-	-	●	-	-
		outward	MCE	FI	●	-	-	-	-
				SI	-	-	-	-	-
	Side-Hung	inward	MCE	SI	■	■	-	-	-
				FI	-	-	■	-	-
			SCE	SI	-	-	-	-	-
		FI		-	-	-	-	-	
		outward	MCE	FI	■	■	-	-	-
				SI	-	-	-	-	-
	SCE		FI	■	■	-	-	-	
		SI	-	-	-	-	-		
Roof	outward	MCE	FI	●	●	-	-	-	
			SI	-	-	-	-	-	
		SCE	FI	-	-	-	-	-	
			SI	-	-	-	-	-	
Parallel-Projecting / Projecting Top-Hung	outward		FI	■	■	-	-	-	
Profile installation					-	-	-	■	■
ESW [4]		Solo	[mm]		600 – 1200				
ESH [4]		Solo	[mm]		250 – 1500				

■ suitable | ● less suitable

[1] Sash dimensions and opening angle may deviate.

[2] Guide value for opening angle calculated for min. ESW/ESH for inward-opening sash with drives mounted on MCE.

Different opening angles will be obtained for other sash heights, for outward-opening sashes and for sashes with drives mounted on the SCE.

[3] Observe attack points of the drives! Guide value for max. sash weight applies for solo drive on Bottom-Hung sash with max. opening angle.

[4] The instructions of the particular profile system, hardware and glass manufacturers must be observed. The specifications for ESW/ESH apply accordingly for Side-Hung sashes.

Chain drive KS4

Fixings – application examples



Application examples

1	2	3
Installation on Bottom-Hung sash, inwards Shown on aluminium window	Frame installation, inward-opening Bottom-Hung sash Shown on aluminium window	Frame installation, inward-opening Bottom-Hung sash Shown on aluminium window
1	3	3
Frame installation, Top-Hung sash, outward Shown on aluminium window	Frame installation, inward-opening Bottom-Hung sash Shown on timber window	Frame installation, inward-opening Top-Hung sash Shown on aluminium window
4	5	
Installation in profile (integrated into profile) in frame, inward-opening Bottom-Hung sash Shown on aluminium window	Installation in profile (integrated into profile) in frame, inward-opening Bottom-Hung sash Shown on timber window	

Chain drive KS4

Fixings – chain holding fixtures – surface-mounted installation

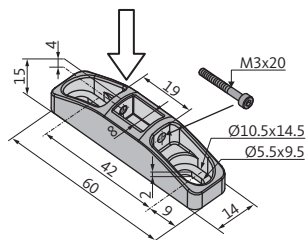

Attach chain in direction of arrow

Chain holding fixture F41

Application

- Surface-mounted installation on sashes and frames of the main and secondary closing edge of inward/outward-opening windows
- For surface-mounted chain drives KS4
- In combination with mounting bracket K132, K134

Finish*	PU	Order number	
Die-cast aluminium, gloss chrome-plated	1 pc	151440	
Contents: 1 x chain holding fixture, 1 x M3x20 screw, 1 x drilling template			

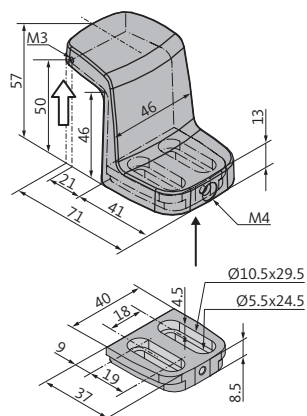

Attach chain in direction of arrow

Chain holding fixture F42

Application

- Surface-mounted installation on sashes of inward-opening windows
- For surface-mounted chain drives KS4

Finish*	PU	Order number	
Die-cast aluminium, gloss chrome-plated	1 pc	151441	
Contents: 1 x chain holding fixture, 1 x base plate, 1 x M4x10 countersunk screw, 1 x M3x25 screw, 1 x drilling template			

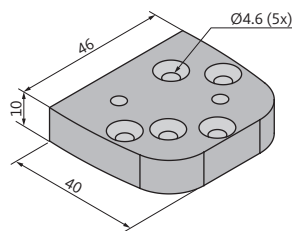

Packer for chain holding fixture F42

Application

- As compensating plate when installed on timber and PVC windows

Finish*	PU	Order number	
Aluminium (EV1)	1 pc	523961	

*Chain holding fixtures painted/powder-coated in special colour (RAL colour) see page 228.

Chain drive KS4

Fixings – chain holding fixtures – profile-integrated installation

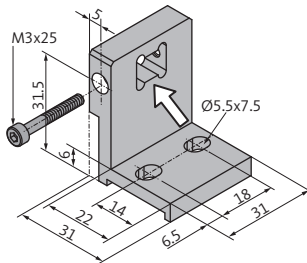

Attach chain in direction of arrow

Chain holding fixture F43

Application

- Surface-mounted installation on Schüco AWS 75 inward-opening window sashes
- For profile-integrated installation of KS4 chain drives
- In combination with mounting bracket K133

Finish*	PU	Order number	
Aluminium (EV1)	1 pc	151444	
Contents: 1 x chain holding fixture, 1 x M3x25 cheese-head screw			

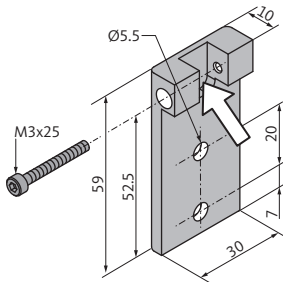

Attach chain in direction of arrow

Chain holding fixture F19

Application

- Surface-mounted installation on inward-opening timber window sashes
- For profile-integrated installation of KS4 chain drives
- In combination with mounting bracket K135

Finish*	PU	Order number	
Aluminium (EV1)	1 pc	151419	
Contents: 1 x chain holding fixture, 1 x M3x25 cheese-head screw			

*Chain holding fixtures painted/powder-coated in special colour (RAL colour) see page 228.

Chain drive KS4

Fixings – mounting brackets – surface-mounted installation

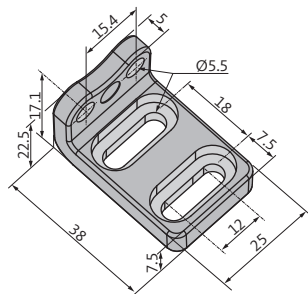

K132 mounting bracket

Application

- Surface-mounted installation on frames of inward-opening windows
- For swivel-mounted attachment of KS4 chain drives
- In combination with chain holding fixture F42

Finish*	PU	Order number	
Die-cast aluminium, gloss chrome-plated	1 pc	522940	
Contents: 2 x mounting bracket, 2 x M5x16 screw			

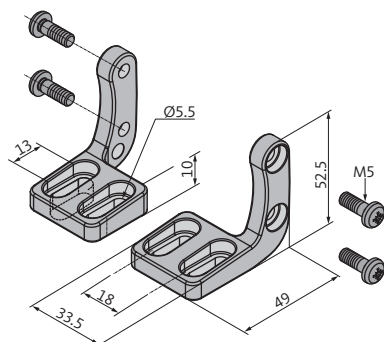

K134 mounting bracket

Application

- Surface-mounted installation on sashes and frames of inward/outward-opening windows
- For fixed or swivel-mounted attachment of KS4 chain drives
- In combination with chain holding fixture F41

Finish*	PU	Order number	
Die-cast aluminium, gloss chrome-plated	1 pc	522941	
Contents: 2 x mounting bracket, 4 x M5x10 screw			

*Mounting brackets painted/powder-coated in special colour (RAL colour) see page 228.

Chain drive KS4

Fixings – mounting brackets – profile-integrated installation

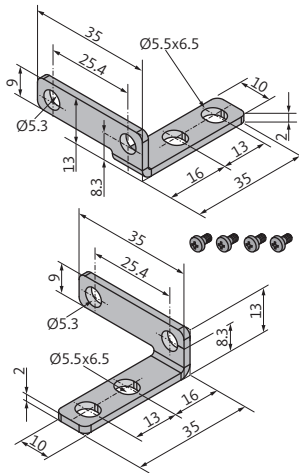

K133 mounting bracket

Application

- Profile-integrated installation in the frame of inward-opening windows
- For fixed attachment of KS4 chain drives
- In combination with chain holding fixture F43

Finish*	PU	Order number	
Stainless steel	1 pc	522946	
Contents: 2 x mounting bracket, 4 x M5x10 screw			

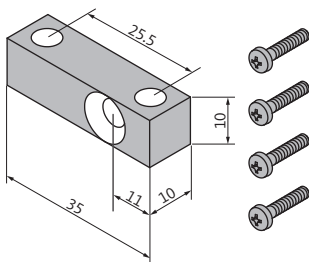

K135 mounting bracket

Application

- Profile-integrated installation in the frame of inward-opening timber windows
- For fixed attachment of KS4 chain drives
- In combination with chain holding fixture F19

Finish*	PU	Order number	
Aluminium, rotofinished	1 pc	522943	
Contents: 2 x mounting bracket, 4 x M5x16 screw			

*Mounting brackets painted/powder-coated in special colour (RAL colour) see page 228.

Chain drive KSA

Product characteristics



24V

230V

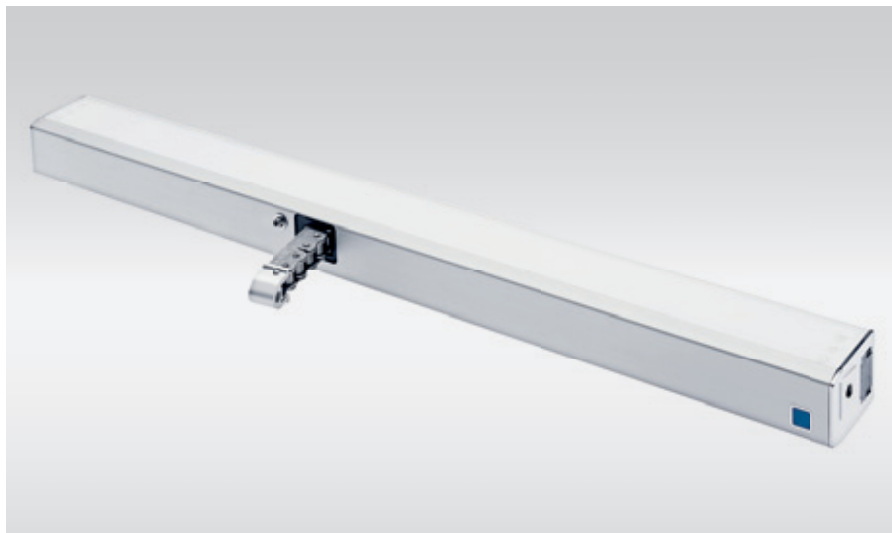

Product characteristics

- For controlled natural ventilation, SHEV and NSHEV according to EN 12101-2
- High-quality rugged stainless steel chain
- Adjustable chain pretension
- Mechanical chain unlocking
- Programmable parameters of the intelligent S12 control electronics*
 - Synchronised multiple operation and sequential control
 - Soft start and soft stop at the end positions
 - Travel, closing force, speed
 - Reversing in the event of overload cut-off during the closing operation
- Integrated plug solution
- Compatible with the pluggable configuration module M-COM Click
- TWIN version: with two chains and twice the force
- Version Z: programmable checkback signal for "OPEN" or "CLOSED" end position (max. 24 V, 500 mA)
- Aluminium body anodised or in RAL colours as option

- For information on protection class SK3 see page 459 (risk assessment for power-operated windows in accordance with Machine Directive 2006/42/EC)
- In addition to the drive system, Bottom-Hung sashes must be equipped with restrictor stays (see pages 226–227)

*For programming of S12 control electronics see page 229.

Chain drive KSA

Technical data



24V

230V

Technical data

Specification	24 V DC		230 V AC
	KSA S12 24V DC	KSA TWIN S12 24V DC	KSA S12 230V AC
Nominal voltage	24 V DC (19 V ... 28 V)	24 V DC (19 V ... 28 V)	230 V AC (50 Hz)
Nominal current	0.9 A	1.8 A	0.2 A
Breaking current	1.2 A	2.4 A	0.2 A
Nominal power	22 W	43 W	46 W
Duty ratio	5 cycles (ED 30% - ON: 3 min. / OFF: 7 min.)		
Protection code	IP32		
Ambient temperature	-5 °C to +60 °C		
Max. pulling force	600 N	1200 N	600 N
Max. thrust	see diagram	1200 N	see diagram
Max. locking force	3000 N [1]	2 x 2500 N [1]	3000 N [1]
Connecting cable	halogen-free, grey 5 x 0.5 mm ² , ~ 3 m	halogen-free, grey 5 x 0.5 mm ² , ~ 3 m	halogen-free, grey 6 x 0.75 mm ² , ~ 3 m
Speed	Travel ≤ 400 OPEN: 8.0 mm/s CLOSED: 8.0 mm/s	Travel ≤ 400 OPEN: 8.0 mm/s CLOSED: 8.0 mm/s	OPEN: 8.0 mm/s CLOSED: 8.0 mm/s
	Travel > 400 to 600 OPEN: 12.0 mm/s CLOSED: 8.0 mm/s	Travel > 400 to 600 OPEN: 12.0 mm/s CLOSED: 8.0 mm/s	
	Travel > 600 OPEN: 13.5 mm/s CLOSED: 8.0 mm/s		
Max. travel	1500 mm	600 mm	1500 mm
Total length	see order information		
Chain clearance	-	see order information	-
Emission sound pressure level	≤ 70 dB (A)		

[1] depends on fixing

Pulling force + thrust with reference to travel

KSA S12 24V DC | KSA S12 230V AC

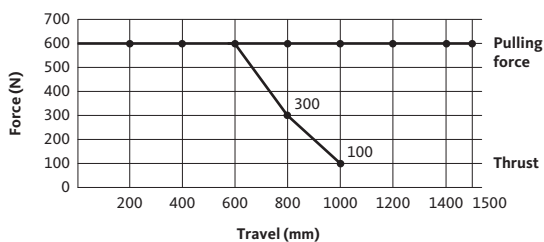

Travel > 600 mm only for tensile load

Chain drive KSA







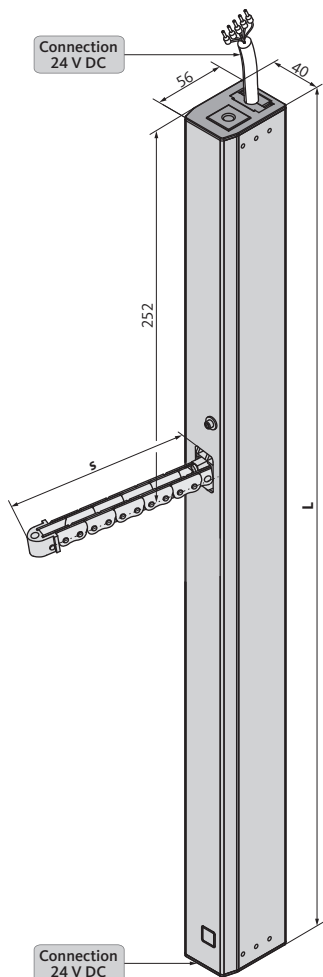

Order information – version KSA S12 24V DC



24V





Order information



Specification	KSA S12 24V DC				
	Travel [s]	Length [L]	Finish*	PU	Order number
KSA 250 S12 24V	250 mm	515 mm	EV1	1 pc	522725 
KSA 300 S12 24V	300 mm	591 mm	EV1	1 pc	522730 
KSA 400 S12 24V	400 mm	591 mm	EV1	1 pc	522740 
KSA 500 S12 24V	500 mm	693 mm	EV1	1 pc	522750 
KSA 600 S12 24V	600 mm	693 mm	EV1	1 pc	522760 
KSA 800 S12 24V	800 mm	794 mm	EV1	1 pc	522780 
KSA 1000 S12 24V	1000 mm	896 mm	EV1	1 pc	522810 
KSA 1200 S12 24V	1200 mm	998 mm	EV1	1 pc	522812 
KSA 1500 S12 24V	1500 mm	1151 mm	EV1	1 pc	522815 

*Drive housing painted in special colour (RAL colour) see page 228.

Plug solution

Wire Click	PU	Order number
5 m – halogen-free, grey – 5 x 0.5 mm ²	1 pc	501252 
10 m – halogen-free, grey – 5 x 0.5 mm ²	1 pc	501253 

Optional accessories

Specification	PU	Order number
M-COM Click configuration module for interconnected drive systems	1 pc	524167 
M-COM configuration module for interconnected drive systems	1 pc	524177 

Chain drive KSA







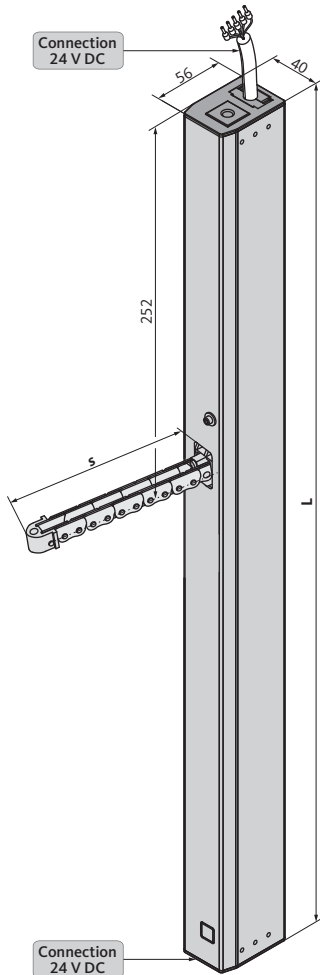

Order information – version KSA S12 24V DC Z version



24V





Order information



Specification	KSA S12 24V DC Z version				
	Travel [s]	Length [L]	Finish*	PU	Order number
KSA 250 S12 24V Z	250 mm	515 mm	EV1	1 pc	522723 
KSA 300 S12 24V Z	300 mm	591 mm	EV1	1 pc	522733 
KSA 400 S12 24V Z	400 mm	591 mm	EV1	1 pc	522743 
KSA 500 S12 24V Z	500 mm	693 mm	EV1	1 pc	522753 
KSA 600 S12 24V Z	600 mm	693 mm	EV1	1 pc	522763 
KSA 800 S12 24V Z	800 mm	794 mm	EV1	1 pc	522783 
KSA 1000 S12 24V Z	1000 mm	896 mm	EV1	1 pc	522813 
KSA 1200 S12 24V Z	1200 mm	998 mm	EV1	1 pc	522823 
KSA 1500 S12 24V Z	1500 mm	1151 mm	EV1	1 pc	522853 

*Drive housing painted in special colour (RAL colour) see page 228.

Plug solution

Wire Click	PU	Order number
5 m – halogen-free, grey – 5 x 0.5 mm ²	1 pc	501252 
10 m – halogen-free, grey – 5 x 0.5 mm ²	1 pc	501253 

Optional accessories

Specification	PU	Order number
M-COM Click configuration module for interconnected drive systems	1 pc	524167 
M-COM configuration module for interconnected drive systems	1 pc	524177 

Chain drive KSA



Order information – version KSA TWIN S12 24V DC

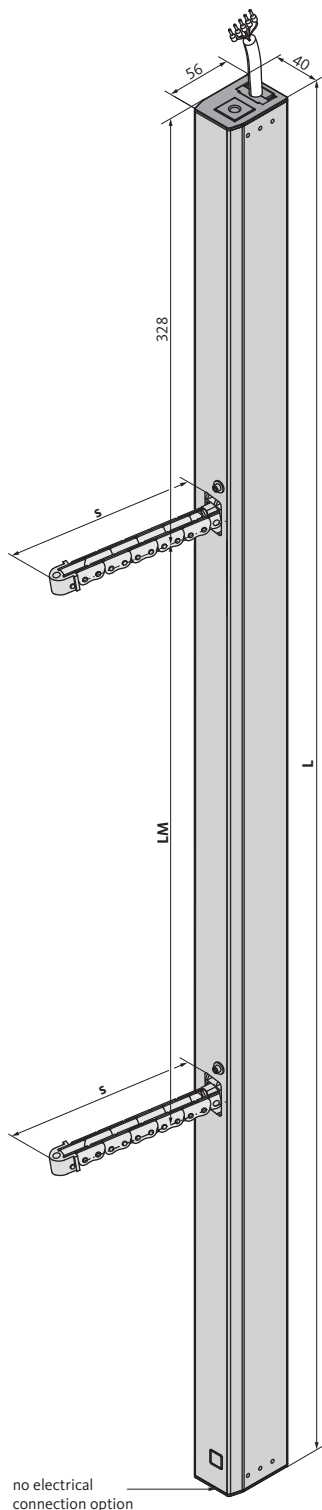

24V





Order information

Specification KSA TWIN	KSA TWIN S12 24V DC					
	Travel [s]	Length [L]	Chain- clearance [LM]	Finish*	PU	Order number
400 S12 24V	400 mm	1150 mm	485 mm	EV1	1 pc	522745 
500 S12 24V	500 mm	1353 mm	587 mm	EV1	1 pc	522755 
600 S12 24V	600 mm	1353 mm	587 mm	EV1	1 pc	522765 

*Drive housing painted in special colour (RAL colour) see page 228.

Plug solution

Wire Click	PU	Order number
5 m – halogen-free, grey – 5 x 0.5 mm ²	1 pc	501252 
10 m – halogen-free, grey – 5 x 0.5 mm ²	1 pc	501253 

Optional accessories

Specification	PU	Order number
M-COM configuration module for interconnected drive systems	1 pc	524177 

Chain drive KSA



Order information – KSA TWIN S12 24V DC Z version

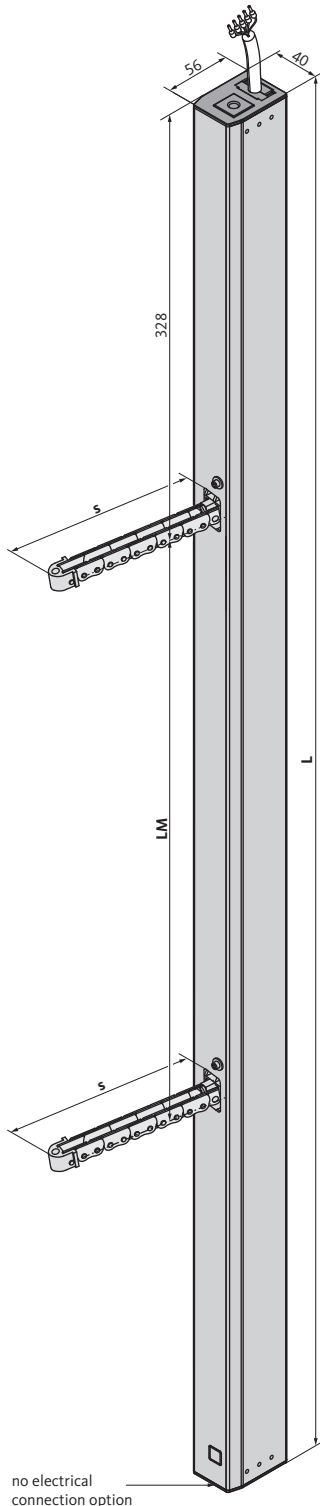

24V





Order information

Specification KSA TWIN	KSA TWIN S12 24V DC Z version					
	Travel [s]	Length [L]	Chain- clearance [LM]	Finish*	PU	Order number
400 S12 24V Z	400 mm	1150 mm	485 mm	EV1	1 pc	522747 
500 S12 24V Z	500 mm	1353 mm	587 mm	EV1	1 pc	522757 
600 S12 24V Z	600 mm	1353 mm	587 mm	EV1	1 pc	522767 

*Drive housing painted in special colour (RAL colour) see page 228.

Plug solution

Wire Click	PU	Order number
5 m – halogen-free, grey – 5 x 0.5 mm ²	1 pc	501252 
10 m – halogen-free, grey – 5 x 0.5 mm ²	1 pc	501253 

Optional accessories

Specification	PU	Order number
M-COM configuration module for interconnected drive systems	1 pc	524177 

Chain drive KSA







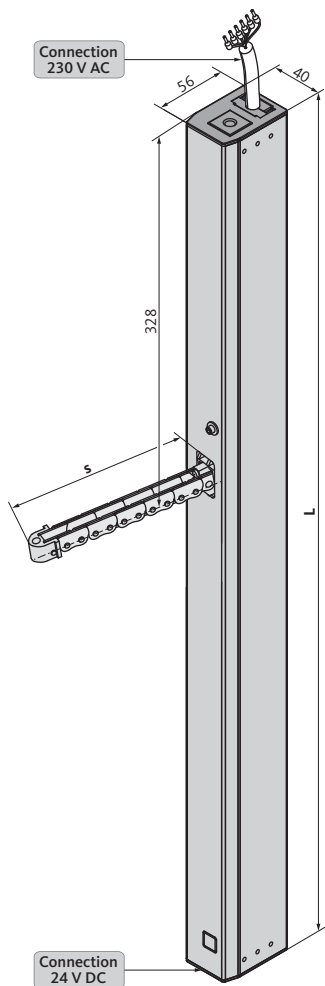

Order information – version KSA S12 230V AC



230V





Order information

Specification	KSA S12 230V AC				
	Travel [s]	Length [L]	Finish*	PU	Order number
KSA 250 S12 230V	250 mm	591 mm	EV1	1 pc	497025 
KSA 300 S12 230V	300 mm	667 mm	EV1	1 pc	497030 
KSA 400 S12 230V	400 mm	667 mm	EV1	1 pc	497040 
KSA 500 S12 230V	500 mm	769 mm	EV1	1 pc	497050 
KSA 600 S12 230V	600 mm	769 mm	EV1	1 pc	497060 
KSA 800 S12 230V	800 mm	870 mm	EV1	1 pc	497080 
KSA 1000 S12 230V	1000 mm	972 mm	EV1	1 pc	497110 
KSA 1200 S12 230V	1200 mm	1074 mm	EV1	1 pc	497112 
KSA 1500 S12 230V	1500 mm	1227 mm	EV1	1 pc	497115 

*Drive housing painted in special colour (RAL colour) see page 228.

Plug solution

Wire Click	PU	Order number
5 m – halogen-free, grey – 6 x 0.75 mm ²	1 pc	501275 
10 m – halogen-free, grey – 6 x 0.75 mm ²	1 pc	501280 

Chain drive KSA







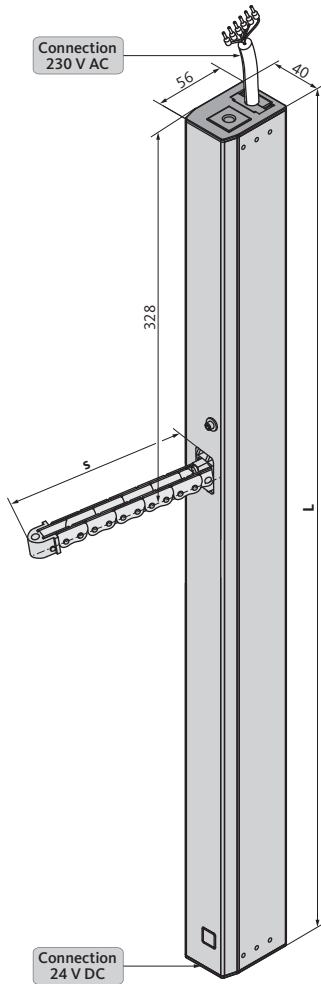

Order information – version KSA S12 230V AC Z version



230V





Order information

Specification	KSA S12 230V AC Z version				
	Travel [s]	Length [L]	Finish*	PU	Order number
KSA 250 S12 230V Z	250 mm	591 mm	EV1	1 pc	497023 
KSA 300 S12 230V Z	300 mm	667 mm	EV1	1 pc	497033 
KSA 400 S12 230V Z	400 mm	667 mm	EV1	1 pc	497043 
KSA 500 S12 230V Z	500 mm	769 mm	EV1	1 pc	497053 
KSA 600 S12 230V Z	600 mm	769 mm	EV1	1 pc	497063 
KSA 800 S12 230V Z	800 mm	870 mm	EV1	1 pc	497083 
KSA 1000 S12 230V Z	1000 mm	972 mm	EV1	1 pc	497113 
KSA 1200 S12 230V Z	1200 mm	1074 mm	EV1	1 pc	497123 
KSA 1500 S12 230V Z	1500 mm	1227 mm	EV1	1 pc	497153 

*Drive housing painted in special colour (RAL colour) see page 228.

Plug solution

Wire Click	PU	Order number
5 m – halogen-free, grey – 6 x 0.75 mm ²	1 pc	501275 
10 m – halogen-free, grey – 6 x 0.75 mm ²	1 pc	501280 

Chain drive KSA

Fixings – overview



Overview of fixings

Example of application				1	2	3	4	5	
Mounting bracket				K-A1	K84-1 K-E1 K87 K-E2	K-B1	-		
Chain holding fixture				F16 F49	F16 F29-2 F16-1 F33 F49	F16 F49		K-D3	
Space requirement		min.	[mm]	35	65 – 90	45 – 55		45	
Overlap thickness [1]			[mm]	0 – 21	-	0 – 21		0 – 21	
Opening angle [2]		max.	[DEG]	20	60	50		40	
Sash weight [3]		max.	[kg]	250	130	130		130	
Sash material		Aluminium		■	■	■	■	■	
		Timber		-	■	■	■	■	
		PVC		●	-	■	■	■	
Sash and assembly type	Bottom-Hung	inward	MCE	SI	■	-	■	■	-
				FI	-	-	-	-	■
			SCE	SI	■	-	■	■	-
		FI		-	-	-	-	■	
		outward	MCE	FI	■	-	■	■	-
				SI	-	■	-	-	-
	SCE		FI	■	■	■	■	-	
		SI	-	●	-	-	-		
	Top-Hung	inward	MCE	SI	■	-	■	■	-
				FI	-	-	-	-	■
		outward	MCE	FI	■	■	■	■	-
				SI	-	-	-	-	-
	Side-Hung	inward	MCE	SI	■	-	■	■	-
				FI	-	-	-	-	■
			SCE	SI	■	-	■	■	-
		FI		-	-	-	-	■	
		outward	MCE	SI	■	-	■	■	-
				FI	-	-	-	-	-
	SCE		SI	■	■	■	■	-	
		FI	-	-	-	-	-		
	Roof	outward	MCE	FI	●	-	●	●	-
				SI	-	●	-	-	-
			SCE	FI	●	-	●	●	-
				SI	-	●	-	-	-
Parallel-Projecting / Projecting Top-Hung	outward		FI	■	-	■	■	-	
Profile installation				-	-	-	-	-	
ESW [4]	Solo Sync2		[mm]	700 – 1300 1250 – 2500					
ESH [4]	Solo Sync2		[mm]	450 – 1500 250 – 2500					

■ suitable | ● less suitable

[1] Sash dimensions and opening angle may deviate.

[2] Guide value for opening angle calculated for min. ESW/ESH for inward-opening sash with drives mounted on MCE.

Different opening angles will be obtained for other sash heights, for outward-opening sashes and for sashes with drives mounted on the SCE.

[3] Observe attack points of the drives! Guide value for max. sash weight applies for solo drive on Bottom-Hung sash with max. opening angle.

[4] The instructions of the particular profile system, hardware and glass manufacturers must be observed. The specifications for ESW/ESH apply accordingly for Side-Hung sashes.

Chain drive KSA

Fixings – application examples



Application examples

1	2	2
<p>Frame installation, Top-Hung sash, outward Shown on aluminium window</p>	<p>Frame installation, outward-opening roof sash Shown on aluminium window</p>	<p>Frame installation, outward-opening roof sash Shown on aluminium window</p>
2	2	3
<p>Frame installation, outward-opening roof sash Shown on aluminium window</p>	<p>Frame installation, Projecting Top-Hung sash, outward Shown on aluminium window</p>	<p>Installation on Bottom-Hung sash, inwards Shown on aluminium window</p>
5		
<p>Frame installation, inward-opening Bottom-Hung sash Shown on aluminium window</p>		

Chain drive KSA

Fixings – chain holding fixtures – surface-mounted installation

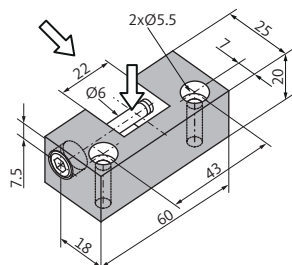

Attach chain in direction of arrow

Chain holding fixture F16

Application

- Surface-mounted installation on sashes and frames of inward/outward-opening windows
- For surface-mounted chain drives KSA
- In combination with mounting brackets K-A1, K-B1, K-B2, K-E1, K-E2, K84-1, K87

Finish*	PU	Order number	
Aluminium (EV1)	1 pc	524204	
Contents: 1 x chain holding fixture, 1 x M6x50 cylinder head screw			

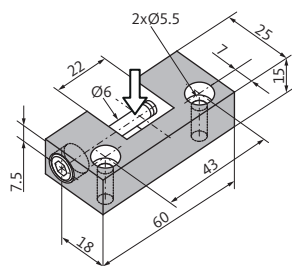

Attach chain in direction of arrow

Chain holding fixture F33

Application

- Surface-mounted installation on sashes of outward-opening windows
- For surface-mounted chain drives KSA
- In combination with mounting brackets K-A1, K-B1, K-B2, K-E1, K-E2, K84-1, K87

Finish*	PU	Order number	
Aluminium (EV1)	1 pc	524203	
Contents: 1 x chain holding fixture, 1 x M6x50 cylinder head screw			

*Chain holding fixtures painted/powder-coated in special colour (RAL colour) see page 228.

Chain drive KSA

Fixings – chain holding fixtures – surface-mounted installation

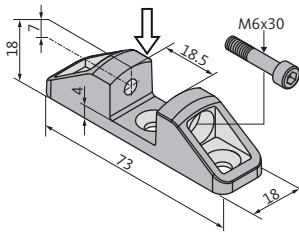

Attach chain in direction of arrow

Chain holding fixture F49

Application

- Surface-mounted installation on sashes and frames of the main and secondary closing edge of inward/outward-opening windows
- For surface-mounted chain drives KSA
- In combination with mounting brackets K-A1, K-B1, K-B2, K-E1, K-E2, K84-1, K125

Finish*	PU	Order number	
Die-cast aluminium (RAL 9006)	1 pc	524299	
Contents: 1 x chain holding fixture, 1 x M6x30 screw			

*Chain holding fixtures painted/powder-coated in special colour (RAL colour) see page 228.

Chain drive KSA

Fixings – mounting brackets – surface-mounted installation

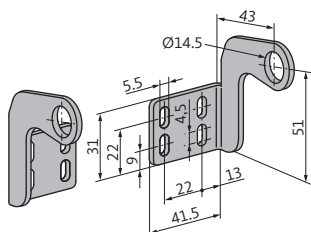

Mounting bracket K-A1

Application

- Surface-mounted installation on sashes and frames of inward/outward-opening windows
- For swivel-mounted attachment of KSA chain drives
- In combination with chain holding fixtures F16, F33, F49
- Space required on frame 35 mm

Finish*	PU	Order number
Stainless steel	1 pc	524057 
Contents: 1 x mounting bracket right, 1 x mounting bracket left		

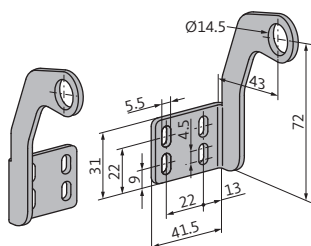

Mounting bracket K-B1

Application

- Surface-mounted installation on sashes and frames of inward/outward-opening windows
- For swivel-mounted attachment of KSA chain drives
- In combination with chain holding fixtures F16, F33, F49
- Space required on frame 35 – 52 mm

Finish*	PU	Order number
Stainless steel	1 pc	524053 
Contents: 1 x mounting bracket right, 1 x mounting bracket left		

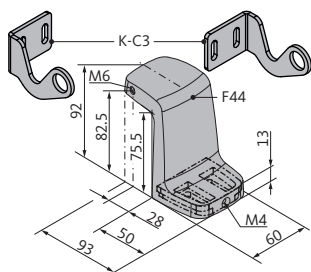

Mounting bracket K-D3

Application

- Surface-mounted installation on sashes and frames of inward-opening windows
- For swivel-mounted attachment of KSA chain drives
- Space required on frame 50 mm

Finish*	PU	Order number
Stainless steel (K-C3) Die-cast aluminium (F44)	1 pc	524068 
Contents: 1 x mounting bracket right (K-C3), 1 x mounting bracket left (K-C3), 1 x chain holding fixture (F44)		

*Mounting brackets painted/powder-coated in special colour (RAL colour) see page 228.

Chain drive KSA

Fixings – mounting brackets – surface-mounted installation

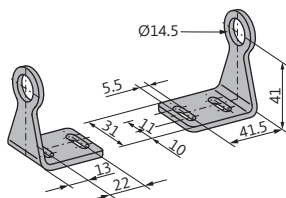

Mounting bracket K-E1

Application

- Surface-mounted installation on mullions/transoms of outward-opening windows
- For swivel-mounted attachment of KSA chain drives
- In combination with chain holding fixtures F16, F33, F49

Finish*	PU	Order number	
Stainless steel	1 pc	524056	
Contents: 1 x mounting bracket right, 1 x mounting bracket left			

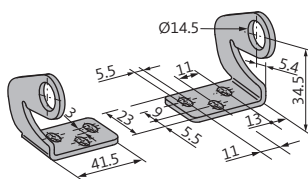

Mounting bracket K-E2

Application

- Surface-mounted installation on frames or mullions/transoms of outward-opening roof windows
- For swivel-mounted attachment of KSA chain drives
- In combination with chain holding fixtures F16, F16-1, F33, F49

Finish*	PU	Order number	
Stainless steel	1 pc	524066	
Contents: 1 x mounting bracket right, 1 x mounting bracket left			

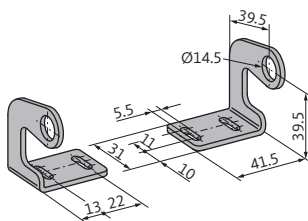

Mounting bracket K84-1

Application

- Surface-mounted installation on frames or mullions/transoms of outward-opening roof windows
- For swivel-mounted attachment of KSA chain drives
- In combination with chain holding fixtures F16, F33, F49

Finish*	PU	Order number	
Stainless steel	1 pc	524224	
Contents: 1 x mounting bracket right, 1 x mounting bracket left			

*Mounting brackets painted/powder-coated in special colour (RAL colour) see page 228.

Chain drive KSA

Fixings – specific applications – Schüco AWS 57 RO roof windows

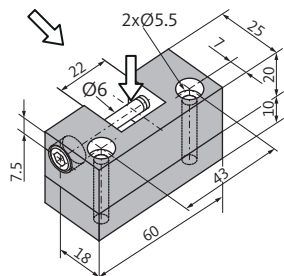

Attach chain in direction of arrow

Chain holding fixture F16-1

Application

- Surface-mounted installation on sashes of Schüco AWS 75 RO outward-opening roof windows
- For surface-mounted chain drives KSA

Finish*	PU	Order number	
Aluminium (EV1)	1 pc	155171	
Contents: 1 x chain holding fixture, 1 x M6x50 cylinder head screw, 1 x packer plate			

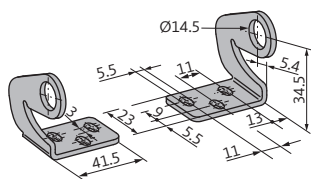

Mounting bracket K-E2

Application

- Surface-mounted installation on frames or mullions/transoms of outward-opening roof windows
- For swivel-mounted attachment of KSA chain drives
- In combination with chain holding fixtures F16, F16-1, F33, F49

Finish*	PU	Order number	
Stainless steel	1 pc	524066	
Contents: 1 x mounting bracket right, 1 x mounting bracket left			

*Chain holding fixtures/mounting brackets painted/powder-coated in special colour (RAL colour) see page 228.

Chain drive KSA

Fixings – specific applications – Schüco FW50 Projecting Top-Hung windows

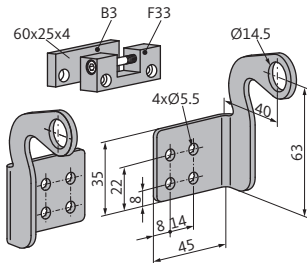

K87 mounting bracket

Application

- Surface-mounted installation on frames of outward-opening Schüco FW50+ Projecting Top-Hung windows
- For swivel-mounted attachment of KSA chain drives
- Space required on frame 35 mm

Finish*	PU	Order number	
Stainless steel	1 pc	524319	
Contents: 1 x mounting bracket right, 1 x mounting bracket left, 1 x chain holding fixture (F33), 1 x packer plate (B3)			

*Mounting brackets painted/powder-coated in special colour (RAL colour) see page 228.

Chain drive KSA

Fixings – specific applications – Heroal 085 / 180 roof windows

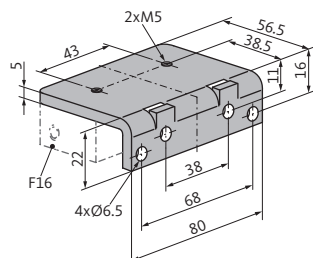

Chain holding fixture F29-2

Application

- Surface-mounted installation on sashes of Heroal 085/180 outward-opening roof windows
- For surface-mounted chain drives KSA
- In combination with chain holding fixture F16

Finish*	PU	Order number	
Stainless steel	1 pc	155157	
Contents: 1 x chain holding fixture, 2 x M6x20 cylinder head screw			

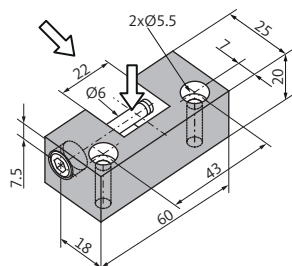

Chain holding fixture F16

Application

- Surface-mounted installation on sashes and frames of inward/outward-opening windows
- For surface-mounted chain drives KSA
- In combination with mounting brackets K-A1, K-B1, K-B2, K-E1, K-E2, K84-1, K87

Finish*	PU	Order number	
Aluminium (EV1)	1 pc	524204	
Contents: 1 x chain holding fixture, 1 x M6x50 cylinder head screw			

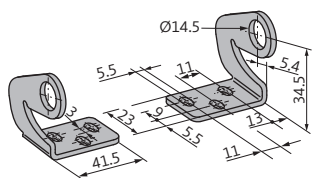

Mounting bracket K-E2

Application

- Surface-mounted installation on frames or mullions/transoms of outward-opening roof windows
- For swivel-mounted attachment of KSA chain drives
- In combination with chain holding fixtures F16, F16-1, F33, F49

Finish*	PU	Order number	
Stainless steel	1 pc	524066	
Contents: 1 x mounting bracket right, 1 x mounting bracket left			

*Chain holding fixtures/mounting brackets painted/powder-coated in special colour (RAL colour) see page 228.



Chain drive KS15

Product characteristics



24V

230V

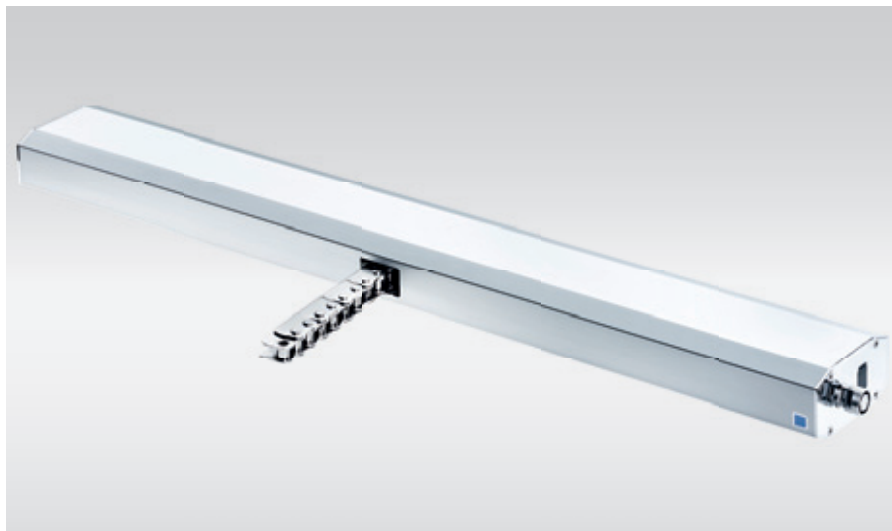

Product characteristics

- For controlled natural ventilation, SHEV and NSHEV according to EN 12101-2
- High-quality rugged nickel-plated steel chain
- Symmetrical chain outlet
- Short design due to triple-wound chain
- Particularly quiet running
- Programmable parameters of the intelligent S12 control electronics*
 - Checkback signal for "OPEN" end position (max. 24 V, 500 mA)
 - Synchronised multiple operation and sequential control
 - Soft start and soft stop at the end positions
 - Travel, closing force, speed
 - Reversing in the event of overload cut-off during the closing operation
- Checkback signal for "CLOSED" end position (max. 24 V, 500 mA)
- Integrated plug solution
- Aluminium body anodised or in RAL colours as option

- For information on protection class SK3 see page 459 (risk assessment for power-operated windows in accordance with Machine Directive 2006/42/EC)
- In addition to the drive system, Bottom-Hung sashes must be equipped with restrictor stays (see pages 226–227)

*For programming of S12 control electronics see page 229.

Chain drive KS15

Technical data



24V

230V

Technical data

Specification	24 V DC	230 V AC
	KS15 S12 24V	KS15 S12 230V
Nominal voltage	24 V DC (19 V ... 28 V)	230 V AC (50 Hz)
Nominal current	3.75 A	0.45 A
Breaking current	5.0 A	0.60 A
Nominal power	90 W	103 W
Duty ratio	5 cycles (ED 30% - ON: 3 min. / OFF: 7 min.)	5 cycles (ED 30% - ON: 3 min. / OFF: 7 min.)
Protection code	IP20	IP20
Ambient temperature	-5 °C to +60 °C	-5 °C to +60 °C
Max. pulling force	Freely adjustable: 300 N to 1500 N Preset: 1000 N, soft running 300 N	Freely adjustable: 300 N to 1500 N Preset: 1000 N, soft running 300 N
Max. thrust	1500 N, up to 1000 mm linear	1500 N, up to 1000 mm linear
Max. locking force	5000 N [1]	5000 N [1]
Connecting cable	halogen-free, grey, Ø 9 mm 5 x 1.0 mm ² , ~ 3 m	halogen-free, grey, Ø 9 mm 6 x 0.75 mm ² , ~ 3 m
Speed	Freely adjustable: 6.0 mm/s to 17 mm/s Preset: 17 mm/s	Freely adjustable: 6.0 mm/s to 17 mm/s Preset: 17 mm/s
Max. travel	1000 mm	1000 mm
Total length	see order information	see order information
Monitoring contact	"CLOSED" end position (max. 24 V, 500 mA)	"CLOSED" end position (max. 24 V, 500 mA)
Emission sound pressure level	≤ 70 dB (A)	≤ 70 dB (A)

[1] depends on fixing

Chain drive KS15



Order information – version KS15 S12 24V DC

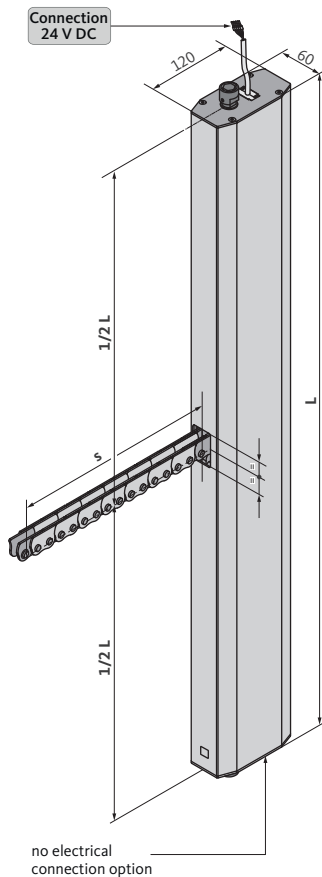

24V



Order information

Specification	KS15 S12 24V DC				
	Travel [s]	Length [L]	Finish*	PU	Order number
KS15 800 S12 24V	800 mm	800 mm	EV1	1 pc	525380 
KS15 1000 S12 24V	1000 mm	920 mm	EV1	1 pc	525400 

*Drive housing painted in special colour (RAL colour) see page 228.

Plug solution

Wire Click	PU	Order number
5 m – halogen-free, grey – 5 x 1.0 mm ²	1 pc	501290 

Optional accessories

Specification	PU	Order number
M-COM configuration module for interconnected drive systems	1 pc	524177 

Chain drive KS15

Order information – version KS15 S12 230V AC



230V

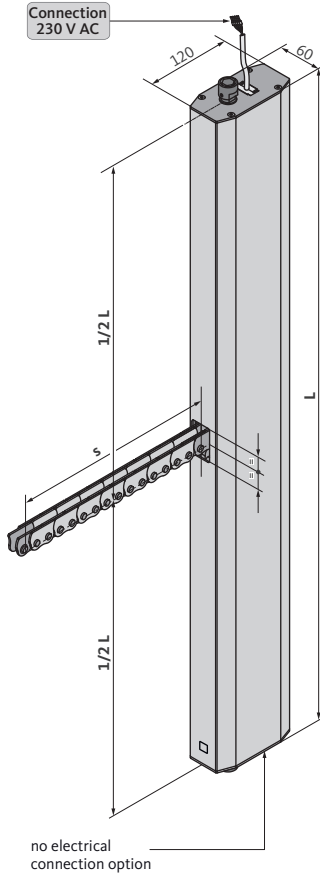

Order information

Specification	KS15 S12 230V AC				
	Travel [s]	Length [L]	Finish*	PU	Order number
KS15 1000 S12 230V	1000 mm	920 mm	EV1	1 pc	495170 

*Drive housing painted in special colour (RAL colour) see page 228.

Plug solution

Wire Click	PU	Order number
5 m – halogen-free, grey – 6 x 0.75 mm ²	1 pc	501292 

Chain drive KS15

Fixings – overview



Overview of fixings

Example of application					1	2
Mounting bracket					K153	K154
Chain holding fixture					F54	F54
Space requirement			min.	[mm]	49	49
Overlap thickness [1]				[mm]	0 – 21	0 – 21
Opening angle [2]			max.	[DEG]	60	60
Sash weight [3]			max.	[kg]	300	300
Sash material			Aluminium		■	■
			Timber		■	■
			PVC		■	■
Sash and assembly type	Top-Hung	outward	MCE	FI	■	-
				SI	-	-
	Roof	outward	MCE	FI	■	■
				SI	-	-
ESW [4]			Solo	[mm]	600 – 1200	
ESH [4]			Solo	[mm]	250 – 1500	

[1] Sash dimensions and opening angle may deviate.

[2] Guide value for opening angle calculated for min. ESW/ESH for inward-opening sash with drives mounted on MCE.

Different opening angles will be obtained for other sash heights, for outward-opening sashes and for sashes with drives mounted on the SCE.

[3] Observe attack points of the drives! Guide value for max. sash weight applies for solo drive on Bottom-Hung sash with max. opening angle.

[4] The instructions of the particular profile system, hardware and glass manufacturers must be observed. The specifications for ESW/ESH apply accordingly for Side-Hung sashes.

Chain drive KS15

Fixings – application examples



Application examples

1	2
<p>Frame installation, outward-opening roof sash Schüco AWS 57 RO Shown on aluminium window</p>	<p>Frame installation, outward-opening roof sash Raico FRAME+ 100/120 RI Shown on aluminium window</p>
2	
<p>Frame installation, Top-Hung sash, outward Universal installation for façade Shown on aluminium window</p>	

Chain drive KS15

Fixing set – Schüco AWS 57 RO roof window

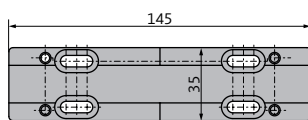
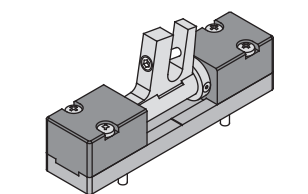
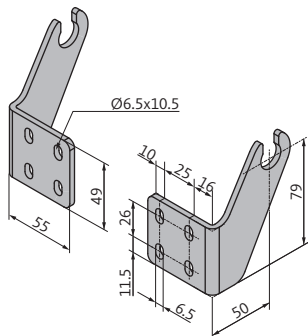

Mounting bracket set KS15 Schüco AWS 57 RO

Application

- Surface-mounted installation on frames of Schüco AWS 57 RO outward-opening roof windows
- For swivel-mounted attachment of KS15 chain drives
- In combination with chain holding fixture F54

Finish*	PU	Order number	
Stainless steel, rotofinished (K153) Aluminium EV1 (F54)	1 pc	524080	
Contents: 1 x fastening bracket right + left (K153), 1 x chain holding fixture (F54) consisting of base plate, chain mount, M5x30 screws, M5x30 Allen screw			

*Chain holding fixtures/mounting brackets painted/powder-coated in special colour (RAL colour) see page 228.

Chain drive KS15

Fixing set – Raico FRAME+ 100/120 RI roof windows

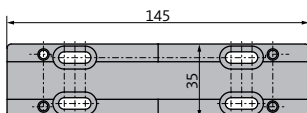
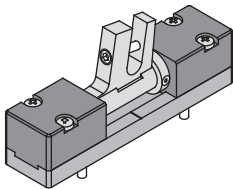
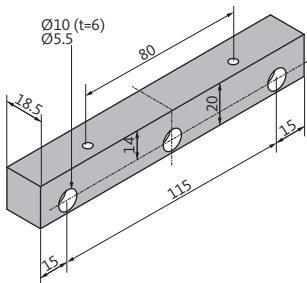
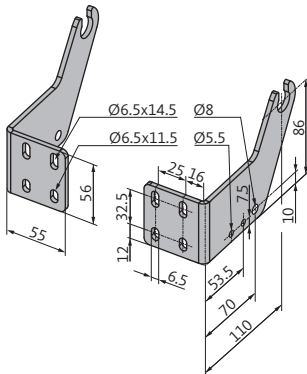

Set of mounting brackets KS15 Raico FRAME+ 100/120 RI

Application

- Surface-mounted installation on frames of Raico FRAME+ 100/120 RI outward-opening roof windows
- For swivel-mounted attachment of KS15 chain drives
- In combination with chain holding fixture F54

Finish*	PU	Order number	
Stainless steel, rotofinished (K154) Aluminium EV1 (F54)	1 pc	524085	
Contents: 1 x fastening bracket right + left (K154), fastening block, 1 x chain holding fixture (F54) consisting of base plate, chain mount, M5x30 screws, M5x30 Allen screw			

*Chain holding fixtures/mounting brackets painted/powder-coated in special colour (RAL colour) see page 228.

Chain drive ELTRAL KS20

Product characteristics



24V

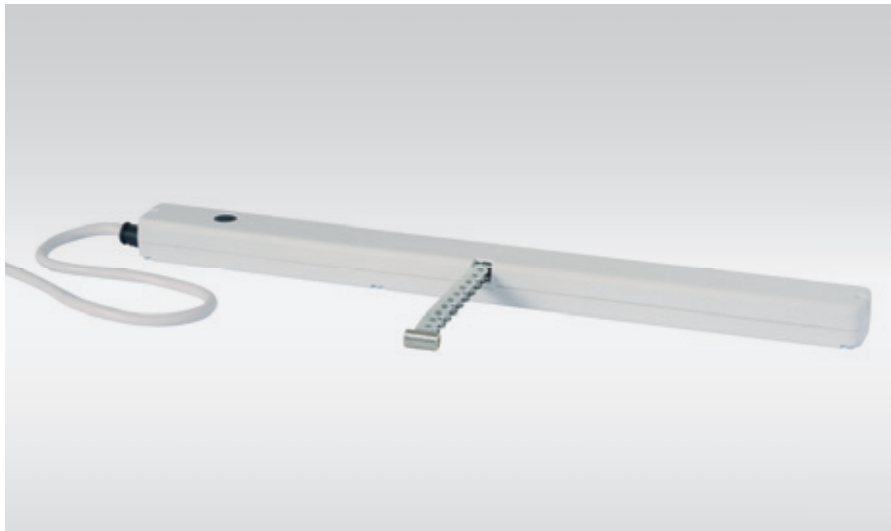

Product characteristics

- Smallest dimensions: 21 x 28 x 354 mm
- The intelligent control electronics
 - ensures synchronisation of up to 8 drives without additional connection of closed-loop and sequential controls
 - ensures automatic end and overload cut-off regardless of the overlap thicknesses
 - enables automatic seal relief
- Reduced closing speed (max. 5 mm/s) for the last 50 mm – corresponds to protection class SK3
- With LED display for installation and/or fault messages
- Suitable for small sash heights from 300 mm
- Travel adjustment in 3 stages:
 - 250 mm to 170 mm or 100 mm
- Straightforward direct installation with lateral mounting brackets
- Quiet thanks to patented chain and PVC housing

Dimensions

ELTRAL KS20

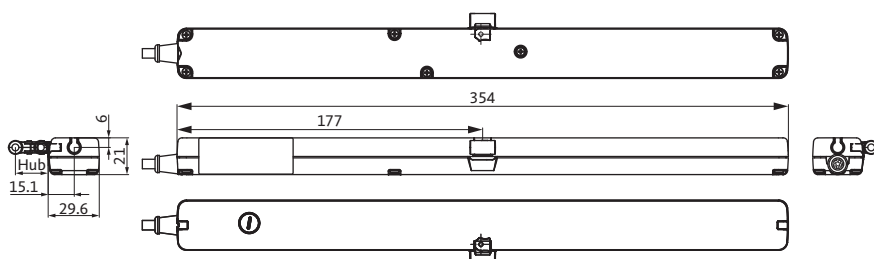

Chain drive ELTRAL KS20

Technical data | Order information



24V

Technical data

Specification	24 V DC
	ELTRAL KS20
Nominal voltage	24 V DC
Nominal current	0.45 A
Breaking current	1.0 A
Duty ratio	30 %
Protection code	IP42
Ambient temperature	-5 °C to +60 °C
Max. pulling force	200 N
Max. locking force	1000 N
Connecting cable	Silicone halogen-free; 3 x 0.5 mm ² , ~ 2 m
Max. travel	250 mm
Total length	354 mm

Travel [mm]	Pushing force [N]	Runtime [s]
100	150	25
170	150	42
250	120	62

Order information

ELTRAL KS20						
Specification	Connecting cable		Surface	PU	Order number	
	Length	Type				
ELTRAL KS20 Solo	2 m	3 x 0.5 mm ²	Grey (RAL 9006)	1 pc	K-20527-00-0-1	
	2 m	3 x 0.5 mm ²	Black (RAL 9005)	1 pc	K-20527-00-0-6	
	2 m	3 x 0.5 mm ²	Traffic white (RAL 9010)	1 pc	K-20527-00-0-7	

Contents: 1 x chain drive, fixing set

- As a result of the PVC body, this drive is not approved in the SHEV sector within the EU.
- For information on protection class SK3 see page 459 (risk assessment for power-operated windows in accordance with Machine Directive 2006/42/EC)
- Special cable lengths on request
- Special colours on request
- Fixing sets for standard applications are included in the scope of delivery
- In addition to the drive system, Bottom-Hung sashes must be equipped with restrictor stays (see pages 226–227)

Chain drive ELTRAL KS20

Mounting bracket sets – surface-mounted installation

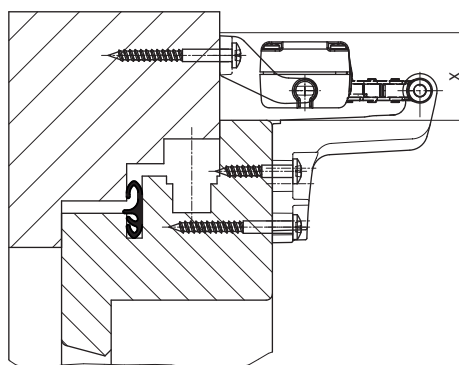
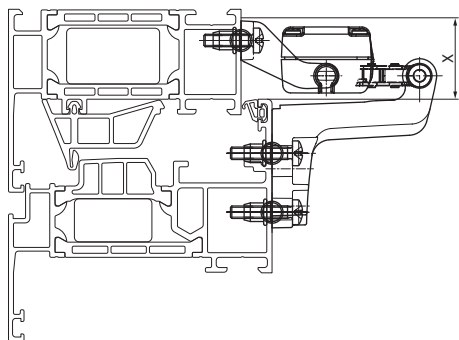

Fixing set KS20

Technical data	
Opening type	Bottom-Hung window Top-Hung window Side-Hung window
Type of installation	surface-mounted
Type of installation Bottom-Hung window (drive)	Frame installation (FI)
Type of installation Top-Hung window (drive)	Frame installation (FI)
Type of installation Side-Hung window (drive)	Frame installation (FI)
Opening direction Bottom-Hung window	inward
Opening direction Top-Hung window	inward
Opening direction Side-Hung window	inward
Frame material	Aluminium Timber PVC [1]
Space requirement X min. Aluminium Timber Plastic [mm]	26 26 26

Travel [mm]	Sash height min. for FI [mm]
250	300

Finish	PU	Order number
Grey (RAL 9006)	1 pc	included in the delivery scope of the drive
Black (RAL 9005)	1 pc	
White (RAL 9010)	1 pc	

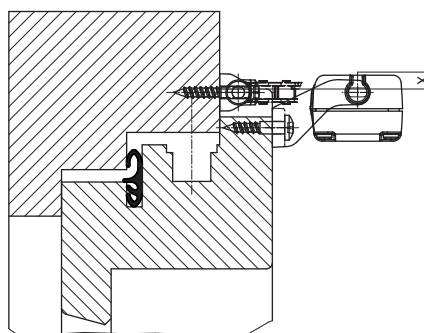
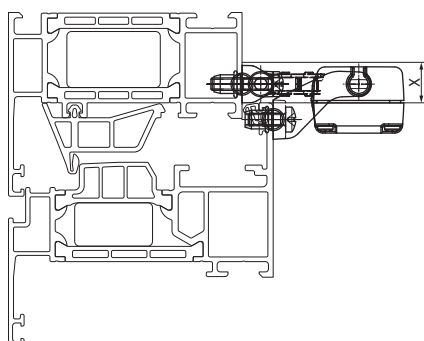

Fixing set KS20

Technical data	
Opening type	Bottom-Hung window Top-Hung window Side-Hung window
Type of installation	surface-mounted
Type of installation Bottom-Hung window (drive)	Sash installation (SI)
Type of installation Top-Hung window (drive)	Frame installation (FI)
Type of installation Side-Hung window (drive)	Frame installation (FI)
Opening direction Bottom-Hung window	inward
Opening direction Top-Hung window	inward outward
Opening direction Side-Hung window	inward
Frame material	Aluminium Timber PVC [1]
Space requirement X min. Aluminium Timber Plastic [mm]	13 13 13

Travel [mm]	Min. sash height [mm]	
	SI	FI
250	300	300

Finish	PU	Order number
Grey (RAL 9006)	1 pc	included in the delivery scope of the drive
Black (RAL 9005)	1 pc	
White (RAL 9010)	1 pc	

[1] Without fixing screws

Chain drive ELTRAL KS20

Mounting bracket sets – concealed installation

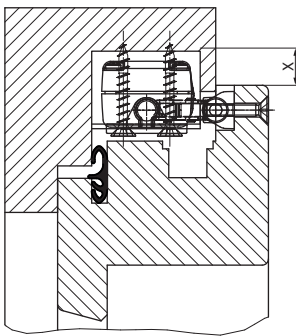
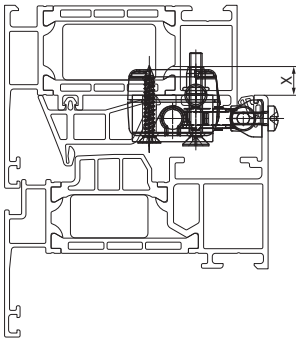

Fixing set KS20

Technical data

Opening type	Bottom-Hung window Top-Hung window Side-Hung window
Type of installation	surface-mounted
Type of installation Bottom-Hung window (drive)	Frame installation (FI)
Type of installation Top-Hung window (drive)	Frame installation (FI)
Type of installation Side-Hung window (drive)	Frame installation (FI)
Opening direction Bottom-Hung window	inward
Opening direction Top-Hung window	inward
Opening direction Side-Hung window	inward
Frame material	Aluminium Timber PVC [1]
Space requirement X min. Aluminium Timber Plastic [mm]	10 10 10

Travel [mm]	Sash height min. for FI [mm]
250	300

Finish	PU	Order number
Grey (RAL 9006)	1 pc	included in the delivery scope of the drive
Black (RAL 9005)	1 pc	
White (RAL 9010)	1 pc	

[1] Without fixing screws

Chain drive ELTRAL K30

Product characteristics



24V

230V



Product characteristics

- Tested and certified in accordance with EN 12101-2
- Compact size
- Synchronised tandem operation
- The integrated microprocessor control unit
 - ensures automatic end and overload cut-off regardless of the overlap thicknesses
 - enables automatic seal relief
- Reduced closing speed (max. 5 mm/s) for the last 50 mm – corresponds to protection class SK3
- Suitable for small sash heights from 350 mm
- Travel adjustment in 3 stages:
 - 500 mm to 400 mm or 300 mm
- Painted aluminium housing

Dimensions

ELTRAL K30

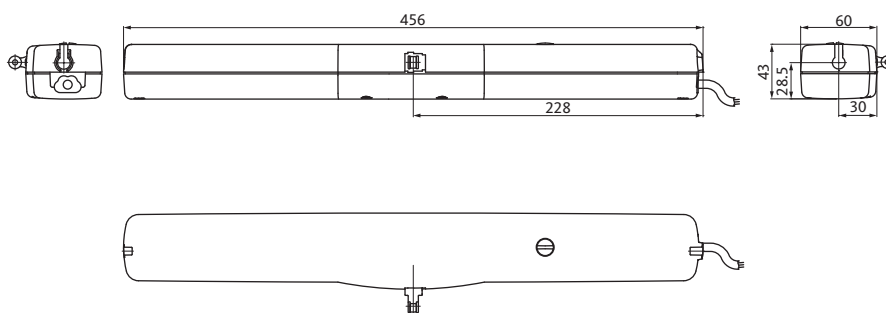

Chain drive ELTRAL K30

Technical data



24V

230V

Technical data

Specification	24 V DC	230 V AC
	ELTRAL K30	ELTRAL K30
Nominal voltage	24 V DC	230 V AC
Nominal current	0.9 A	0.16 A
Breaking current	1.2 A	-
Duty ratio	30 %	30 %
Protection code	IP32	IP32
Ambient temperature	-5 °C to +60 °C	-5 °C to +60 °C
Max. pulling force	300 N	300 N
Max. locking force	2000 N	2000 N
Max. travel	500 mm	500 mm
Total length	456 mm	456 mm

Travel [mm]	Pushing force [N]	Runtime [s]
300	300	34
400	300	45
500	300	56

Chain drive ELTRAL K30

Order information – version ELTRAL K30 24 V DC



24V

Order information

ELTRAL K30 24 V DC

Specification	Connecting cable		Surface	PU	Order number	
	Length	Type				
ELTRAL K30 Solo	2 m	3 x 0.5 mm ²	Silver (RAL 9006)	1 pc	K-17832-00-0-1	
	2 m	3 x 0.5 mm ²	Black (RAL 9005)	1 pc	K-17832-00-0-6	
	2 m	3 x 0.5 mm ²	Traffic white (RAL 9010)	1 pc	K-17832-00-0-7	
Contents: 1 x chain drive						
ELTRAL K30 Synchro	2.5 m	5 x 0.5 mm ²	Silver (RAL 9006)	1 pc	K-17833-00-0-1	
	2.5 m	5 x 0.5 mm ²	Black (RAL 9005)	1 pc	K-17833-00-0-6	
	2.5 m	5 x 0.5 mm ²	Traffic white (RAL 9010)	1 pc	K-17833-00-0-7	
Contents: 2 x chain drive						
ELTRAL K30 Solo with VAN	2 m	3 x 0.5 mm ²	Silver (RAL 9006)	1 pc	K-18023-00-0-1	
	2 m	3 x 0.5 mm ²	Black (RAL 9005)	1 pc	K-18023-00-0-6	
	2 m	3 x 0.5 mm ²	Traffic white (RAL 9010)	1 pc	K-18023-00-0-7	
Contents: 1 x chain drive, 1 x locking drive						
ELTRAL K30 Synchro with VAN	2.5 m	5 x 0.5 mm ²	Silver (RAL 9006)	1 pc	K-18024-00-0-1	
	2.5 m	5 x 0.5 mm ²	Black (RAL 9005)	1 pc	K-18024-00-0-6	
	2.5 m	5 x 0.5 mm ²	Traffic white (RAL 9010)	1 pc	K-18024-00-0-7	
Contents: 2 x chain drive, 1 x locking drive						

- For information on protection class SK3 see page 459 (risk assessment for power-operated windows in accordance with Machine Directive 2006/42/EC)
- Special cable lengths on request
- Special colours on request

- Fixing sets must be ordered separately (see following pages)
- In addition to the drive system, Bottom-Hung sashes must be equipped with restrictor stays (see pages 226–227)

Chain drive ELTRAL K30

Order information – version ELTRAL K30 230 V AC



230V

Order information

ELTRAL K30 230 V AC						
Specification	Connecting cable		Surface	PU	Order number	
	Length	Type				
ELTRAL K30 Solo	2 m	3 x 0.5 mm ²	Silver (RAL 9006)	1 pc	K-17834-00-0-1	
	2 m	3 x 0.5 mm ²	Black (RAL 9005)	1 pc	K-17834-00-0-6	
	2 m	3 x 0.5 mm ²	Traffic white (RAL 9010)	1 pc	K-17834-00-0-7	
Contents: 1 x chain drive						
ELTRAL K30 Synchro	2.5 m	5 x 0.5 mm ²	Silver (RAL 9006)	1 pc	K-17835-00-0-1	
	2.5 m	5 x 0.5 mm ²	Black (RAL 9005)	1 pc	K-17835-00-0-6	
	2.5 m	5 x 0.5 mm ²	Traffic white (RAL 9010)	1 pc	K-17835-00-0-7	
Contents: 2 x chain drive						

- For information on protection class SK3 see page 459 (risk assessment for power-operated windows in accordance with Machine Directive 2006/42/EC)

- Special cable lengths on request

- Special colours on request

- Fixing sets must be ordered separately (see following pages)

- In addition to the drive system, Bottom-Hung sashes must be equipped with restrictor stays (see pages 226–227)

Chain drive ELTRAL K30

Mounting bracket sets – surface-mounted installation

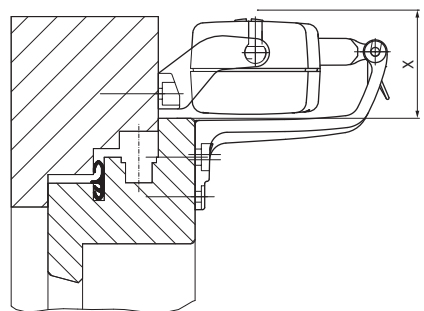
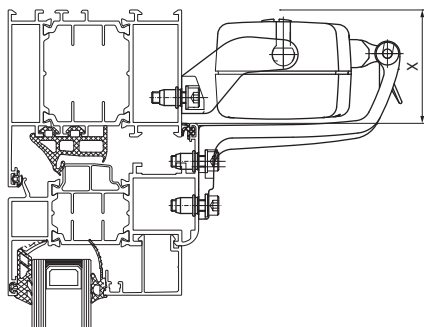

Fixing set K30

Technical data

Opening type	Bottom-Hung window Top-Hung window Side-Hung window
Type of installation	surface-mounted
Type of installation Bottom-Hung window (drive)	Frame installation (FI)
Type of installation Top-Hung window (drive)	Frame installation (FI)
Type of installation Side-Hung window (drive)	Frame installation (FI)
Opening direction Bottom-Hung window	inward
Opening direction Top-Hung window	inward
Opening direction Side-Hung window	inward
Frame material	Aluminium Timber PVC [1]
Space requirement X min. Aluminium Timber Plastic [mm]	50 50 50

Travel [mm]	Sash height min. for FI [mm]
300	350
400	550
500	700

Finish	PU	Order number
Silver painted (RAL 9006)	1 pc	K-18157-00-0-1
Black painted (RAL 9005)	1 pc	K-18157-00-0-6
White painted (RAL 9010)	1 pc	K-18157-00-0-7

[1] Without fixing screws

Chain drive ELTRAL K30

Mounting bracket sets – surface-mounted installation

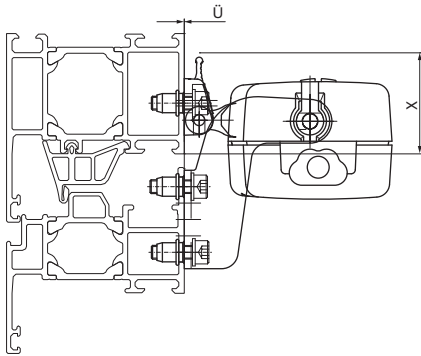

Fixing set K30

Technical data

Opening type	Bottom-Hung window Top-Hung window Side-Hung window
Type of installation	surface-mounted
Type of installation Bottom-Hung window (drive)	Sash installation (SI)
Type of installation Top-Hung window (drive)	Frame installation (FI)
Type of installation Side-Hung window (drive)	Frame installation (FI)
Opening direction Bottom-Hung window	inward
Opening direction Top-Hung window	inward outward
Opening direction Side-Hung window	inward
Overlap OL [mm] [2]	0
Frame material	Aluminium Timber PVC [1]
Space requirement X min. Aluminium Timber Plastic [mm]	37 37 37

Travel [mm]	Min. sash height [mm]	
	SI	FI
300	500	350
400	700	450
500	900	600

Finish	PU	Order number
Silver painted (RAL 9006)	1 pc	K-17841-00-0-1
Black painted (RAL 9005)	1 pc	K-17841-00-0-6
White painted (RAL 9010)	1 pc	K-17841-00-0-7

[1] without fixing screws | [2] only for frame installation, outward Top-Hung window

Chain drive ELTRAL K30

Mounting bracket sets – surface-mounted installation

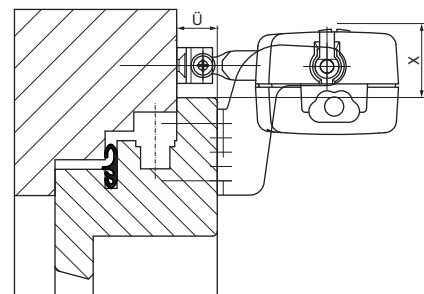
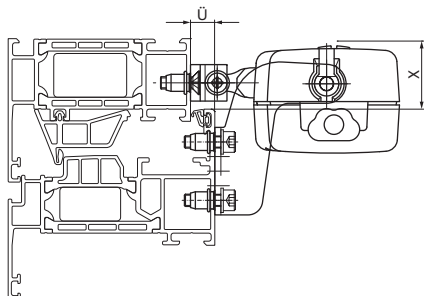

Fixing set K30

Technical data	
Opening type	Bottom-Hung window Top-Hung window Side-Hung window
Type of installation	surface-mounted
Type of installation Bottom-Hung window (drive)	Sash installation (SI)
Type of installation Top-Hung window (drive)	Frame installation (FI)
Type of installation Side-Hung window (drive)	Frame installation (FI)
Opening direction Bottom-Hung window	inward
Opening direction Top-Hung window	inward outward
Opening direction Side-Hung window	inward
Overlap OL [mm] [2]	4
Frame material	Aluminium Timber PVC [1]
Space requirement X min. Aluminium Timber Plastic [mm]	28 31 31

Travel [mm]	Min. sash height [mm]	
	SI	FI
300	500	350
400	700	450
500	900	600

Finish	PU	Order number
Silver painted (RAL 9006)	1 pc	K-17843-00-0-1
Black painted (RAL 9005)	1 pc	K-17843-00-0-6
White painted (RAL 9010)	1 pc	K-17843-00-0-7

[1] without fixing screws | [2] only for frame installation, outward Top-Hung window

Chain drive ELTRAL K30

Mounting bracket sets – surface-mounted installation

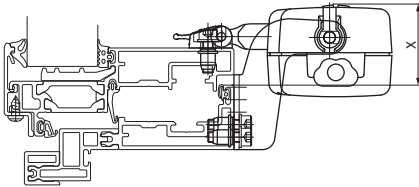

Fixing set K30

Technical data

Opening type	Projecting Top-Hung window
Type of installation	surface-mounted
Type of installation Top-Hung window (drive)	Frame installation (FI)
Opening direction Top-Hung window	outward
Frame material	Aluminium [1]
Space requirement X min. Aluminium Timber Plastic [mm]	39 - -

Travel [mm]	Sash height min. for FI [mm]
300	350
400	450
500	600

Finish	PU	Order number
Silver painted (RAL 9006)	1 pc	K-17840-00-0-1
Black painted (RAL 9005)	1 pc	K-17840-00-0-6
White painted (RAL 9010)	1 pc	K-17840-00-0-7

[1] Without fixing screws

Chain drive ELTRAL KS 30/40

Product characteristics



24V

230V



Product characteristics

- Cost-effective and efficient entry model
 - Compact size
 - Synchronised tandem operation
 - The integrated microprocessor control unit
 - ensures automatic end and overload cut-off regardless of the overlap thicknesses
 - enables automatic seal relief
 - Reduced closing speed (max. 5 mm/s) for the last 50 mm – corresponds to protection class SK3
 - Suitable for small sash heights from 250 mm
 - Travel adjustment in 3 stages:
 - 400 mm to 300 mm or 200 mm
 - Quick and simple installation with the accompanying installation template
 - Painted PVC housing
- With ELTRAL KS 30/40 radio**
- With integrated radio receiver
 - Radio remote control and/or ventilation push-button

Dimensions

ELTRAL KS 30/40

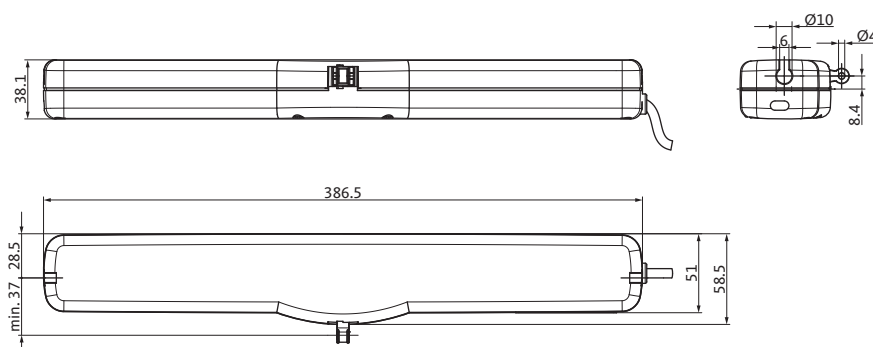

Chain drive ELTRAL KS 30/40

Technical data



24V

230V

Technical data

Specification	24 V DC	230 V AC	
	ELTRAL KS 30/40	ELTRAL KS 30/40	ELTRAL KS 30/40 radio
Nominal voltage	24 V DC \pm 15 %	230 V AC \pm 15 %	230 V AC \pm 15 %
Nominal current	0.9 A	0.12 A	0.16 A
Breaking current	1.2 A	-	-
Duty ratio	30 %	30 %	30 %
Protection code	IP30	IP30	IP30
Ambient temperature	-5 °C to +60 °C	-5 °C up to +60 °C	-5 °C to +60 °C
Max. pulling force	300 N	300 N	300 N
Max. locking force	1000 N	1000 N	1000 N
Max. travel	400 mm	400 mm	400 mm
Total length	386 mm	386 mm	386 mm

Travel [mm]	Pushing force [N]	Runtime [s]
200	300	22
300	250	33
400	200	44

Chain drive ELTRAL KS 30/40

Order information – version ELTRAL KS 30/40 24 V DC



24V

Order information

ELTRAL KS 30/40 24 V DC

Specification	Connecting cable		Surface	PU	Order number	
	Length	Type				
ELTRAL KS 30/40 Solo	2 m	3 x 0.75 mm ²	Silver (RAL 7047)	1 pc	K-17434-00-0-1	
	2 m	3 x 0.75 mm ²	Black (RAL 9004)	1 pc	K-17434-00-0-6	
	2 m	3 x 0.75 mm ²	Traffic white (RAL 9003)	1 pc	K-17434-00-0-7	
	5 m	3 x 0.75 mm ²	Silver (RAL 7047)	1 pc	K-17434-05-0-1	
	5 m	3 x 0.75 mm ²	Black (RAL 9004)	1 pc	K-17434-05-0-6	
	5 m	3 x 0.75 mm ²	Traffic white (RAL 9003)	1 pc	K-17434-05-0-7	
Contents: 1 x chain drive						
ELTRAL KS 30/40 Synchro	2.5 m	5 x 0.75 mm ²	Silver (RAL 7047)	1 pc	K-17436-02-0-1	
	2.5 m	5 x 0.75 mm ²	Black (RAL 9004)	1 pc	K-17436-02-0-6	
	2.5 m	5 x 0.75 mm ²	Traffic white (RAL 9003)	1 pc	K-17436-02-0-7	
Contents: 2 x chain drive						
ELTRAL KS 30/40 Solo with VAN	2 m	3 x 0.75 mm ²	Silver (RAL 7047)	1 pc	K-18025-00-0-1	
	2 m	3 x 0.75 mm ²	Black (RAL 9004)	1 pc	K-18025-00-0-6	
	2 m	3 x 0.75 mm ²	Traffic white (RAL 9003)	1 pc	K-18025-00-0-7	
Contents: 1 x chain drive, 1 x locking drive						
ELTRAL KS 30/40 Synchro with VAN	2.5 m	5 x 0.75 mm ²	Silver (RAL 7047)	1 pc	K-18026-00-0-1	
	2.5 m	5 x 0.75 mm ²	Black (RAL 9004)	1 pc	K-18026-00-0-6	
	2.5 m	5 x 0.75 mm ²	Traffic white (RAL 9003)	1 pc	K-18026-00-0-7	
Contents: 2 x chain drive, 1 x locking drive						

■ As a result of the PVC body, this drive is not approved in the SHEV sector within the EU.

■ For information on protection class SK3 see page 459 (risk assessment for power-operated windows in accordance with Machine Directive 2006/42/EC)

■ Special cable lengths on request

■ Special colours on request

■ Fixing sets for standard applications are included in the scope of delivery

■ Fixing sets for special application must be ordered separately (see following pages)

■ In addition to the drive system, Bottom-Hung sashes must be equipped with restrictor stays (see pages 226–227)

Chain drive ELTRAL KS 30/40

Order information – version ELTRAL KS 30/40 230 V AC



230V

Order information

ELTRAL KS 30/40 230 V AC						
Specification	Connecting cable		Surface	PU	Order number	
	Length	Type				
ELTRAL KS 30/40 Solo	2 m	3 x 0.75 mm ²	Silver (RAL 7047)	1 pc	K-17433-00-0-1	
	2 m	3 x 0.75 mm ²	Black (RAL 9004)	1 pc	K-17433-00-0-6	
	2 m	3 x 0.75 mm ²	Traffic white (RAL 9003)	1 pc	K-17433-00-0-7	
	5 m	3 x 0.75 mm ²	Silver (RAL 7047)	1 pc	K-17433-05-0-1	
	5 m	3 x 0.75 mm ²	Black (RAL 9004)	1 pc	K-17433-05-0-6	
	5 m	3 x 0.75 mm ²	Traffic white (RAL 9003)	1 pc	K-17433-05-0-7	
Contents: 1 x chain drive						
ELTRAL KS 30/40 Synchro	2.5 m	5 x 0.75 mm ²	Silver (RAL 7047)	1 pc	K-17435-02-0-1	
	2.5 m	5 x 0.75 mm ²	Black (RAL 9004)	1 pc	K-17435-02-0-6	
	2.5 m	5 x 0.75 mm ²	Traffic white (RAL 9003)	1 pc	K-17435-02-0-7	
Contents: 2 x chain drive						

- For information on protection class SK3 see page 459 (risk assessment for power-operated windows in accordance with Machine Directive 2006/42/EC)

- Special cable lengths on request

- Special colours on request

- Fixing sets for standard applications are included in the scope of delivery

- Fixing sets for special application must be ordered separately (see following pages)

- In addition to the drive system, Bottom-Hung sashes must be equipped with restrictor stays (see pages 226–227)

Chain drive ELTRAL KS 30/40



Order information – version ELTRAL KS 30/40 wireless 230 V AC



230V

Order information

ELTRAL KS 30/40 wireless 230 V AC

Specification	Connecting cable		Surface	PU	Order number	
	Length	Type				
ELTRAL KS 30/40 radio	2 m	3 x 0.75 mm ²	Silver (RAL 7047)	1 pc	K-19045-00-0-1	
	2 m	3 x 0.75 mm ²	Black (RAL 9004)	1 pc	K-19045-00-0-6	
	2 m	3 x 0.75 mm ²	Traffic white (RAL 9003)	1 pc	K-19045-00-0-7	

Contents: 1 x chain drive

- Special cable lengths on request
- Special colours on request
- Fixing sets for standard applications are included in the scope of delivery
- Fixing sets for special application must be ordered separately (see following pages)
- In addition to the drive system, Bottom-Hung sashes must be equipped with restrictor stays (see pages 226–227)
- The radio remote control must be ordered separately

Chain drive ELTRAL KS 30/40

Accessories



Radio remote control

- Multichannel radio remote control for individual and group control of ELTRAL KS 30/40 radio chain drives
- Microprocessor-controlled
- With display for functions, transmission status and battery charge level

Technical data

- Dimensions (W x H x D): 38.5 x 145 x 22.5 mm
- Transmission range approx. 50 m

	PU	Order number
	1 pc	K-19046-00-0-0

Chain drive ELTRAL KS 30/40

Mounting bracket sets – surface-mounted installation

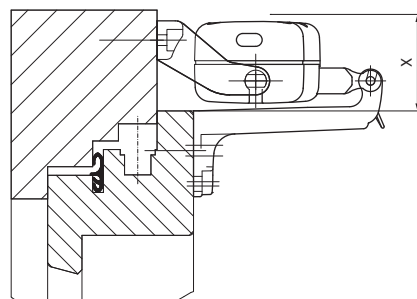
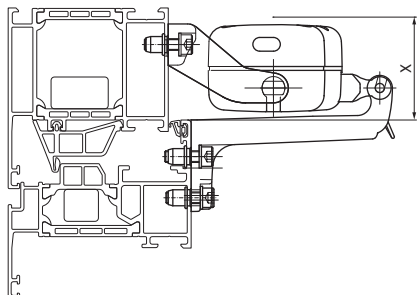

Fixing set KS 30/40

Technical data	
Opening type	Bottom-Hung window Top-Hung window Side-Hung window
Type of installation	surface-mounted
Type of installation Bottom-Hung window (drive)	Frame installation (FI)
Type of installation Top-Hung window (drive)	Frame installation (FI)
Type of installation Side-Hung window (drive)	Frame installation (FI)
Opening direction Bottom-Hung window	inward
Opening direction Top-Hung window	inward
Opening direction Side-Hung window	inward
Frame material	Aluminium Timber PVC [1]
Space requirement X min. Aluminium Timber PVC [mm]	45 45 45

Travel [mm]	Sash height min. for FI [mm]
200	600
300	1100
400	1500

Finish	PU	Order number
Silver painted (RAL 7047)	1 pc	included in the delivery scope of the drive
Black painted (RAL 9004)	1 pc	
White painted (RAL 9016)	1 pc	

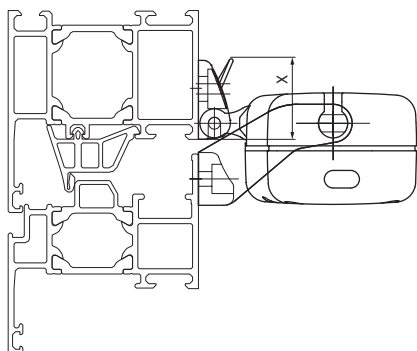

Fixing set KS 30/40

Technical data	
Opening type	Bottom-Hung window Top-Hung window Side-Hung window
Type of installation	surface-mounted
Type of installation Bottom-Hung window (drive)	Sash installation (SI)
Type of installation Top-Hung window (drive)	Frame installation (FI)
Type of installation Side-Hung window (drive)	Frame installation (FI)
Opening direction Bottom-Hung window	inward
Opening direction Top-Hung window	inward outward
Opening direction Side-Hung window	inward
Frame material	Aluminium Timber PVC [1]
Space requirement X min. Aluminium Timber PVC [mm]	28 28 28

Travel [mm]	Min. sash height [mm]	
	SI	FI
200	400	250
300	650	350
400	900	450

Finish	PU	Order number
Silver painted (RAL 7047)	1 pc	included in the delivery scope of the drive
Black painted (RAL 9004)	1 pc	
White painted (RAL 9016)	1 pc	

[1] Without fixing screws

Chain drive ELTRAL KS 30/40

Mounting bracket sets – surface-mounted installation

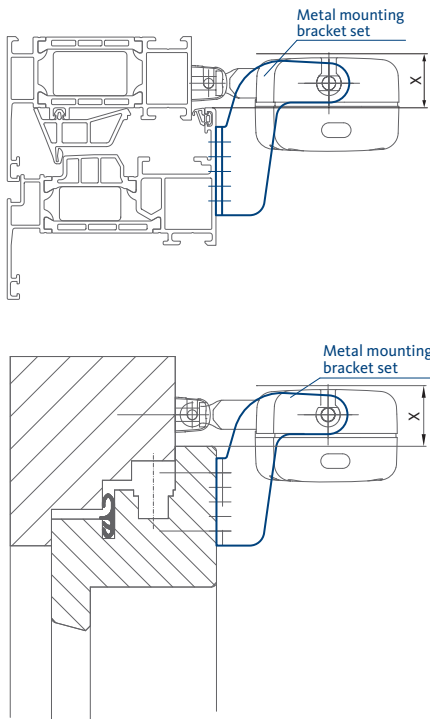

Fixing set KS 30/40

Technical data	
Opening type	Bottom-Hung window Top-Hung window Side-Hung window
Type of installation	surface-mounted
Type of installation Bottom-Hung window (drive)	Sash installation (SI)
Type of installation Top-Hung window (drive)	Frame installation (FI)
Type of installation Side-Hung window (drive)	Frame installation (FI)
Opening direction Bottom-Hung window	inward
Opening direction Top-Hung window	inward outward
Opening direction Side-Hung window	inward
Frame material	Aluminium Timber PVC [1]
Space requirement X min. Aluminium Timber PVC [mm]	22 25 25

Travel [mm]	Min. sash height [mm]	
	SI	FI
200	400	250
300	650	350
400	900	450

Finish	PU	Order number
Silver painted (RAL 7047)	1 pc	K-17720-00-0-1
Black painted (RAL 9004)	1 pc	K-17720-00-0-6
White painted (RAL 9003)	1 pc	K-17720-00-0-7

[1] Without fixing screws

Chain drive ELTRAL KS 30/40

Mounting bracket sets – surface-mounted installation

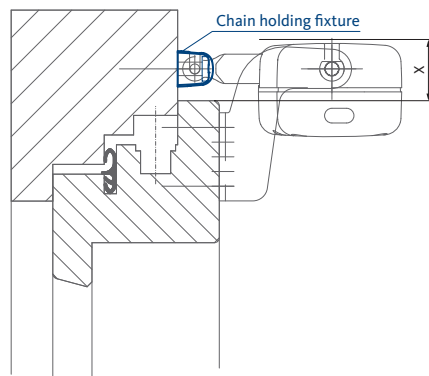
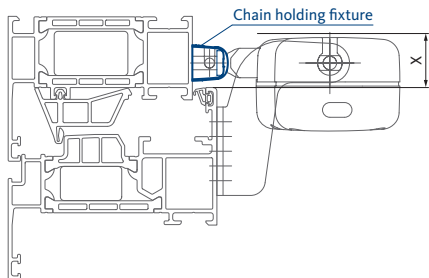

Chain holding fixture

Technical data

Opening type	Bottom-Hung window Top-Hung window Side-Hung window
Type of installation	surface-mounted
Type of installation Bottom-Hung window (drive)	Sash installation (SI)
Type of installation Top-Hung window (drive)	Frame installation (FI)
Type of installation Side-Hung window (drive)	Frame installation (FI)
Opening direction Bottom-Hung window	inward
Opening direction Top-Hung window	inward outward
Opening direction Side-Hung window	inward
Frame material	Aluminium Timber PVC [1]
Space requirement X min. Aluminium Timber PVC [mm]	22 25 25

Travel [mm]	Min. sash height [mm]	
	SI	FI
200	400	250
300	650	350
400	900	450

Finish	PU	Order number
Silver painted (RAL 7047)	1 pc	K-17441-00-0-1
Black painted (RAL 9004)	1 pc	K-17441-00-0-6
White painted (RAL 9003)	1 pc	K-17441-00-0-7

[1] Without fixing screws

Chain drive ELTRAL KS 30/40

Mounting bracket sets – surface-mounted installation

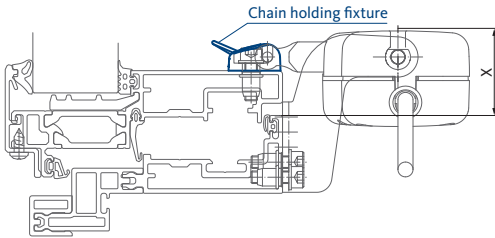

Chain holding fixture

Technical data	
Opening type	Projecting Top-Hung window
Type of installation	surface-mounted
Type of installation Top-Hung window (drive)	Frame installation (FI)
Opening direction Top-Hung window	outward
Frame material	Aluminium Timber PVC [1]
Space requirement X min. Aluminium Timber PVC [mm]	36 36 36

Travel [mm]	Sash height min. for FI [mm]
200	250
300	350
400	450

Finish	PU	Order number
Silver painted (RAL 7047)	1 pc	9-44272-00-0-1
Black painted (RAL 9004)	1 pc	9-44272-00-0-6
White painted (RAL 9003)	1 pc	9-44272-00-0-7

[1] Without fixing screws

Chain drive ELTRAL KS 30/40

Mounting bracket sets – surface-mounted installation

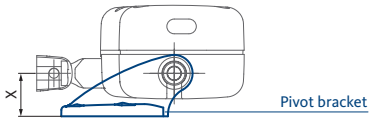

Pivot bracket for installation on reveal

Technical data	
Opening type	Top-Hung window
Type of installation	surface-mounted
Type of installation Top-Hung window (drive)	Frame installation (FI)
Opening direction Top-Hung window	outward
Frame material	Aluminium Timber PVC [1]
Space requirement X min. Aluminium Timber PVC [mm]	17.5 17.5 17.5

Travel [mm]	Sash height min. for FI [mm]
200	600
300	1100
400	1500

Finish	PU	Order number
Silver painted (RAL 7047)	1 pc	K-17440-00-0-1
Black painted (RAL 9004)	1 pc	K-17440-00-0-6
White painted (RAL 9003)	1 pc	K-17440-00-0-7

[1] Without fixing screws

Chain drive ELTRAL KS 30/40

Mounting bracket sets – surface-mounted installation

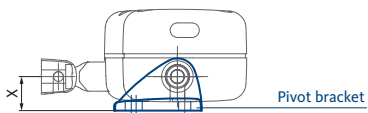

Pivot bracket

Technical data	
Opening type	Skylight
Type of installation	surface-mounted
Type of installation skylight (drive)	Frame installation (FI)
Opening direction skylight	outward
Frame material	Aluminium Timber PVC [1]
Space requirement X min. Aluminium Timber PVC [mm]	14 14 14

Finish	PU	Order number
Silver painted (RAL 7047)	1 pc	K-17735-00-0-1
Black painted (RAL 9004)	1 pc	K-17735-00-0-6
White painted (RAL 9003)	1 pc	K-17735-00-0-7

[1] Without fixing screws

Chain drive ELTRAL K35

Product characteristics



24V



Product characteristics

- Tested and certified in accordance with EN 12101-2
- Small dimensions
- The integrated microprocessor control unit
 - ensures automatic end and overload cut-off regardless of the overlap thicknesses
 - enables automatic seal relief
- Reduced closing speed (max. 5 mm/s) for the last 50 mm – corresponds to protection class SK3
- Suitable for small sash heights from 200 mm
- Travel adjustment in 3 stages:
 - 300 mm to 200 mm or 100 mm
 - 500 mm to 400 mm or 300 mm
 - 800 mm to 700 mm or 600 mm
- Aluminium housing, painted black (RAL 9005)
- Optional: covers for surface-mounted installation

Dimensions

ELTRAL K35

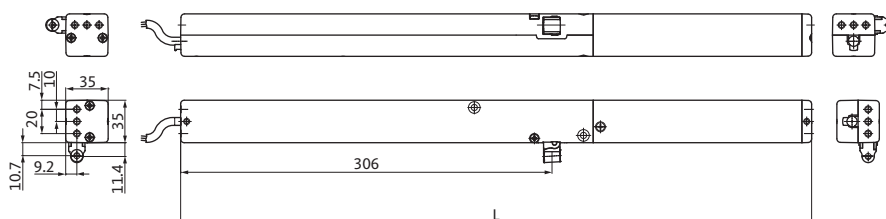

Chain drive ELTRAL K35

Technical data



24V

Technical data

Specification	24 V DC
	ELTRAL K35
Nominal voltage	24 V DC
Nominal current	0.9 A
Breaking current	1.2 A
Duty ratio	30 %
Protection code	IP32
Ambient temperature	-5 °C to +60 °C
Max. pulling force	350 N
Max. locking force	3000 N
Max. travel	300 / 500 / 800 mm
Total length	see order information

Travel [mm]	Pushing force [N]	Runtime [s]
100	350	11
200	350	21
300	350	31
400	200	42
500	100	52
600	50	63
700	50	73
800	50	83

Chain drive ELTRAL K35

Order information



24V

Order information

ELTRAL K35

Specification	Max. travel	Length	Connecting cable		PU	Order number	
			Length	Type			
ELTRAL K35 Solo	300 mm	520 mm	2 m	3 x 0.5 mm ²	1 pc	K-18159-30-0-6	
	500 mm	611 mm	2 m	3 x 0.5 mm ²	1 pc	K-18159-50-0-6	
	800 mm	765 mm	2 m	3 x 0.5 mm ²	1 pc	K-18159-80-0-6	
	300 mm	520 mm	5 m	3 x 0.5 mm ²	1 pc	K-18159-30-5-6	
	500 mm	611 mm	5 m	3 x 0.5 mm ²	1 pc	K-18159-50-5-6	
	800 mm	765 mm	5 m	3 x 0.5 mm ²	1 pc	K-18159-80-5-6	
Contents: 1 x chain drive							
ELTRAL K35 Synchro	300 mm	520 mm	2.5 m	5 x 0.5 mm ²	1 pc	K-18160-30-0-6	
	500 mm	611 mm	2.5 m	5 x 0.5 mm ²	1 pc	K-18160-50-0-6	
	800 mm	765 mm	2.5 m	5 x 0.5 mm ²	1 pc	K-18160-80-0-6	
Contents: 2 x chain drive							
ELTRAL K35 Solo with VAN	300 mm	520 mm	2 m	3 x 0.5 mm ²	1 pc	K-18193-30-0-6	
	500 mm	611 mm	2 m	3 x 0.5 mm ²	1 pc	K-18193-50-0-6	
	800 mm	765 mm	2 m	3 x 0.5 mm ²	1 pc	K-18193-80-0-6	
Contents: 1 x chain drive, 1 x locking drive							
ELTRAL K35 Synchro with VAN	300 mm	520 mm	2.5 m	5 x 0.5 mm ²	1 pc	K-18194-30-0-6	
	500 mm	611 mm	2.5 m	5 x 0.5 mm ²	1 pc	K-18194-50-0-6	
	800 mm	765 mm	2.5 m	5 x 0.5 mm ²	1 pc	K-18194-80-0-6	
Contents: 2 x chain drive, 1 x locking drive							

- For information on protection class SK3 see page 459 (risk assessment for power-operated windows in accordance with Machine Directive 2006/42/EC)
- Special cable lengths on request
- Special colours on request
- Covers must be ordered separately (see following pages)

- Fixing sets must be ordered separately (see following pages)
- Appropriate power supply units for voltage supply and control must be ordered separately (see page 225)
- In addition to the drive system, Bottom-Hung sashes must be equipped with restrictor stays (see pages 226–227)

Chain drive ELTRAL K35

Covers

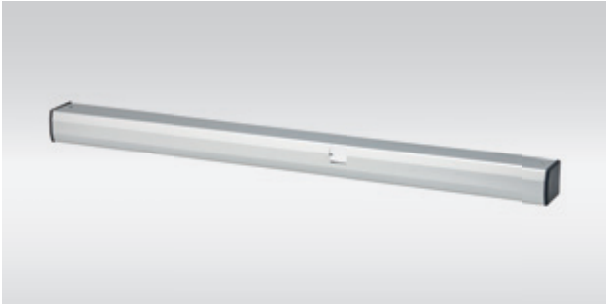

Cover ELTRAL K35
for frame installation, inward-opening

Max. travel [mm]	Finish	PU	Order number
300	EV1, silver	1 pc	K-18323-30-0-1
	White (RAL 9016)	1 pc	K-18323-30-0-7
500	EV1, silver	1 pc	K-18323-50-0-1
	White (RAL 9016)	1 pc	K-18323-50-0-7
800	EV1, silver	1 pc	K-18323-80-0-1
	White (RAL 9016)	1 pc	K-18323-80-0-7

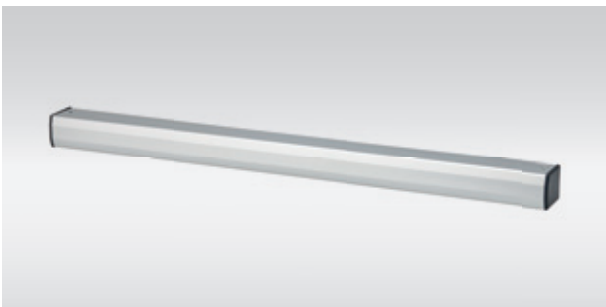

Cover ELTRAL K35
for installation on sash, inward-opening |
for installation on frame, outward-opening

Max. travel [mm]	Finish	PU	Order number
300	EV1, silver	1 pc	K-18324-30-0-1
	White (RAL 9016)	1 pc	K-18324-30-0-7
500	EV1, silver	1 pc	K-18324-50-0-1
	White (RAL 9016)	1 pc	K-18324-50-0-7
800	EV1, silver	1 pc	K-18324-80-0-1
	White (RAL 9016)	1 pc	K-18324-80-0-7

Chain drive ELTRAL K35

Covers

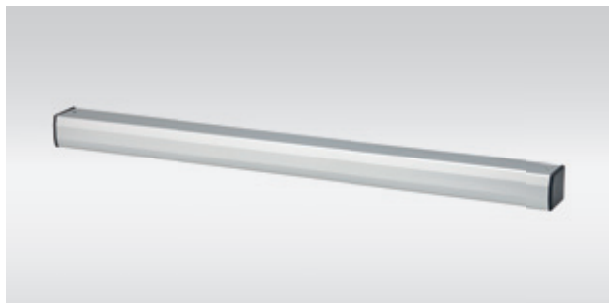

Cover ELTRAL K35 for special lengths and Synchro applications

Length [mm]	Finish	PU	Order number
2000	EV1, silver	1 pc	K-18325-02-0-1
	White (RAL 9016)	1 pc	K-18325-02-0-7

Lengths exceeding 2000 mm on request.



Side cover cap for special lengths | as spare part

Finish	PU	Order number
Black	1 pc	9-46487-00-0-6

Chain drive ELTRAL K35

Mounting bracket sets – surface-mounted installation

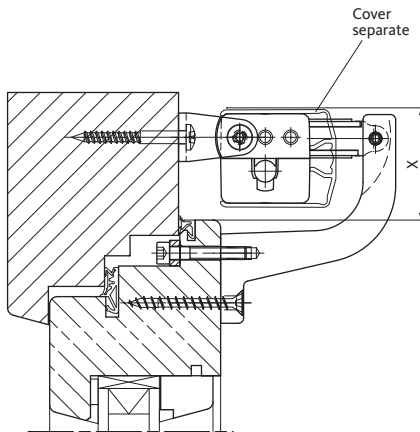
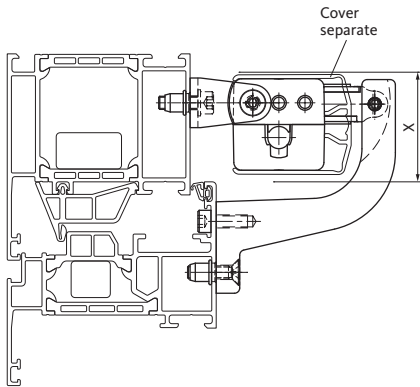

Fixing set K35

Technical data

Opening type	Bottom-Hung window Top-Hung window Side-Hung window
Type of installation	surface-mounted
Type of installation Bottom-Hung window (drive)	Frame installation (FI)
Type of installation Top-Hung window (drive)	Frame installation (FI)
Type of installation Side-Hung window (drive)	Frame installation (FI)
Opening direction Bottom-Hung window	inward
Opening direction Top-Hung window	inward
Opening direction Side-Hung window	inward
Space requirement X min. Aluminium Timber PVC [mm]	42 44 44

Travel [mm]	Sash height min. for FI [mm]
100	200
200	200
300	350
400	500
500	650
600	850
700	1000
800	1200

Frame material	Finish	PU	Order number
Aluminium [1]	Silver painted (RAL 7047)	1 pc	K-18205-00-0-1
	White painted (RAL 9016)	1 pc	K-18205-00-0-7
Timber PVC [2]	Silver painted (RAL 7047)	1 pc	K-18439-00-0-1
	White painted (RAL 9016)	1 pc	K-18439-00-0-7

[1] With fixing screws | [2] Without fixing screws

Chain drive ELTRAL K35

Mounting bracket sets – surface-mounted installation

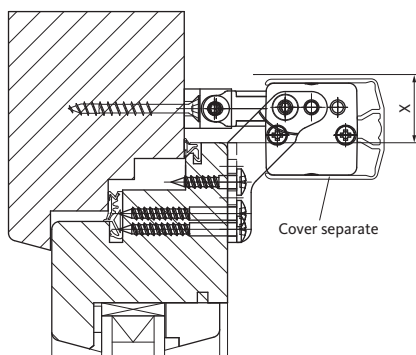
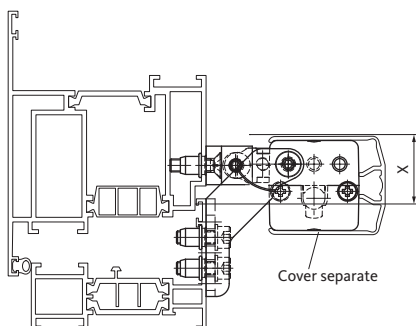
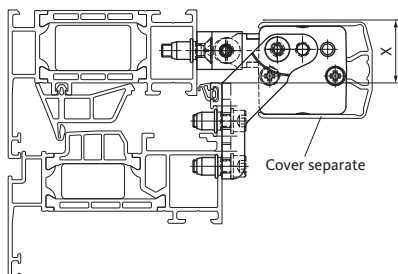

Fixing set K35

Technical data

Opening type	Bottom-Hung window Top-Hung window Side-Hung window
Type of installation	surface-mounted
Type of installation Bottom-Hung window (drive)	Sash installation (SI)
Type of installation Top-Hung window (drive)	Frame installation (FI)
Type of installation Side-Hung window (drive)	Frame installation (FI)
Opening direction Bottom-Hung window	inward
Opening direction Top-Hung window	inward outward
Opening direction Side-Hung window	inward
Space requirement X min. Aluminium Timber PVC [mm]	27 [3] 26 26

Travel [mm]	Min. sash height [mm]	
	SI	FI
100	350	350
200	350	350
300	500	450
400	700	550
500	900	700
600	1100	900
700	1300	1000
800	1500	1100

Frame material	Finish	PU	Order number
Aluminium [1] Timber [2] PVC [2]	Silver painted (RAL 7047)	1 pc	K-18204-00-0-1
	White painted (RAL 9016)	1 pc	K-18204-00-0-7

[1] With fixing screws | [2] Without fixing screws

[3] Space requirement X min. = 25 mm for aluminium Bottom-Hung windows and 27 mm for aluminium Top-Hung windows

Chain drive ELTRAL K35

Mounting bracket sets – concealed installation

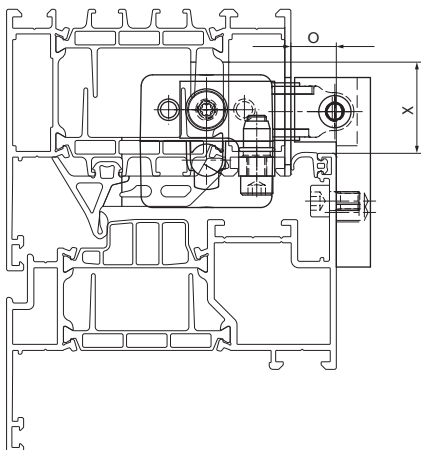

Fixing set K35

Technical data

Opening type	Bottom-Hung window Top-Hung window Side-Hung window
Type of installation	concealed
Type of installation Bottom-Hung window (drive)	Frame installation (FI)
Type of installation Top-Hung window (drive)	Frame installation (FI)
Type of installation Side-Hung window (drive)	Frame installation (FI)
Opening direction Bottom-Hung window	inward
Opening direction Top-Hung window	inward
Opening direction Side-Hung window	inward
Chain holding fixture	surface-mounted
Frame material	Aluminium [1]
Space requirement X min. Aluminium Timber PVC [mm]	24 - -

Travel [mm]	Sash height min. for FI [mm]
100	550
200	550
300	650
400	850
500	1100
600	1300
700	1450
800	1600

Overlap O [mm]	Finish	PU	Order number
7.5-9	Silver painted (RAL 7047)	1 pc	K-18218-00-0-1
	White painted (RAL 9016)	1 pc	K-18218-00-0-7
10-11	Silver painted (RAL 7047)	1 pc	K-18217-00-0-1
	White painted (RAL 9016)	1 pc	K-18217-00-0-7
12	Silver painted (RAL 7047)	1 pc	K-18219-00-0-1
	White painted (RAL 9016)	1 pc	K-18219-00-0-7

[1] With fixing screws | [2] Without fixing screws

[3] Space requirement X min. = 25 mm for aluminium Bottom-Hung windows and 27 mm for aluminium Top-Hung windows

Chain drive ELTRAL K35

Mounting bracket sets – concealed installation

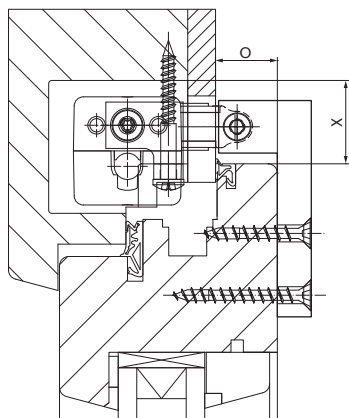

Fixing set K35

Technical data	
Opening type	Bottom-Hung window Top-Hung window Side-Hung window
Type of installation	concealed
Type of installation Bottom-Hung window (drive)	Frame installation (FI)
Type of installation Top-Hung window (drive)	Frame installation (FI)
Type of installation Side-Hung window (drive)	Frame installation (FI)
Opening direction Bottom-Hung window	inward
Opening direction Top-Hung window	inward
Opening direction Side-Hung window	inward
Chain holding fixture	surface-mounted
Frame material	Timber [1]
Space requirement X min. Aluminium Timber PVC [mm]	- 27 -

Travel [mm]	Sash height min. for FI [mm]
100	300
200	300
300	400
400	550
500	700
600	900
700	1100
800	1200

Overlap O [mm]	Finish	PU	Order number
15-20	Silver painted (RAL 7047)	1 pc	K-18418-00-0-1
	White painted (RAL 9016)	1 pc	K-18418-00-0-7

[1] Without fixing screws

Chain drive ELTRAL K35

Mounting bracket sets – concealed installation

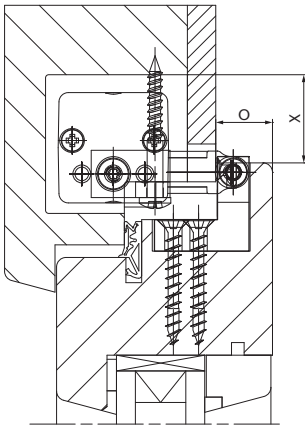

Fixing set K35

Technical data	
Opening type	Bottom-Hung window Top-Hung window Side-Hung window
Type of installation	concealed
Type of installation Bottom-Hung window (drive)	Frame installation (FI)
Type of installation Top-Hung window (drive)	Frame installation (FI)
Type of installation Side-Hung window (drive)	Frame installation (FI)
Opening direction Bottom-Hung window	inward
Opening direction Top-Hung window	inward
Opening direction Side-Hung window	inward
Chain holding fixture	concealed
Frame material	Timber [1]
Space requirement X min. Aluminium Timber PVC [mm]	- 27 -

Travel [mm]	Sash height min. for FI [mm]
100	500
200	500
300	700
400	900
500	1100
600	1300
700	1500
800	1700

Overlap O [mm]	Finish	PU	Order number
18	Silver painted (RAL 7047)	1 pc	K-18512-00-0-1

[1] Without fixing screws





1.2 Locking drives 24 V DC

Locking drive ELTRAL VAN	114
Locking drive FVUI	118
Locking drive FVUR	122
Locking drive FVUB	126
Locking drive OFV	132

Locking drives

Application ranges

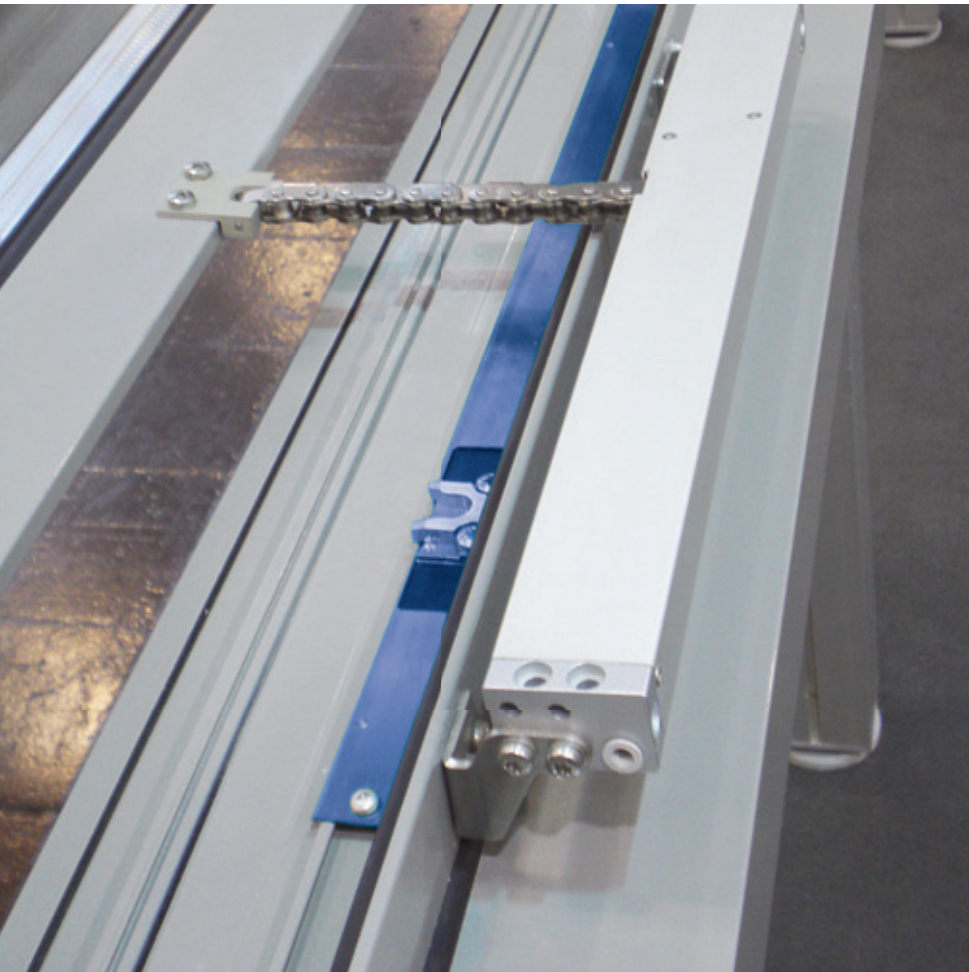

When it comes to heavy window elements with large sash areas and large sash heights in particular, the drive alone is often not enough to keep the window closed.

The locking drives from the Gretsch-Unitas group offer the ideal solution for electromechanical locking and unlocking of Bottom-Hung, Top-Hung, Bottom-Hung, Parallel or Side-Hung windows.

The locking is accomplished either via the interior central locking system (e.g. UNI-JET or ALU-JET) or via a surface-mounted lock. Both the tightness of the window element and the burglar protection are increased by the additional locking points.

The locking drives can be used in combination with a chain drive.

Depending on the profile system (for virtually all standard profiles) and installation situation, drives can be installed on the window or integrated in the window profile for a more sophisticated finish.

Locking drives

Application ranges

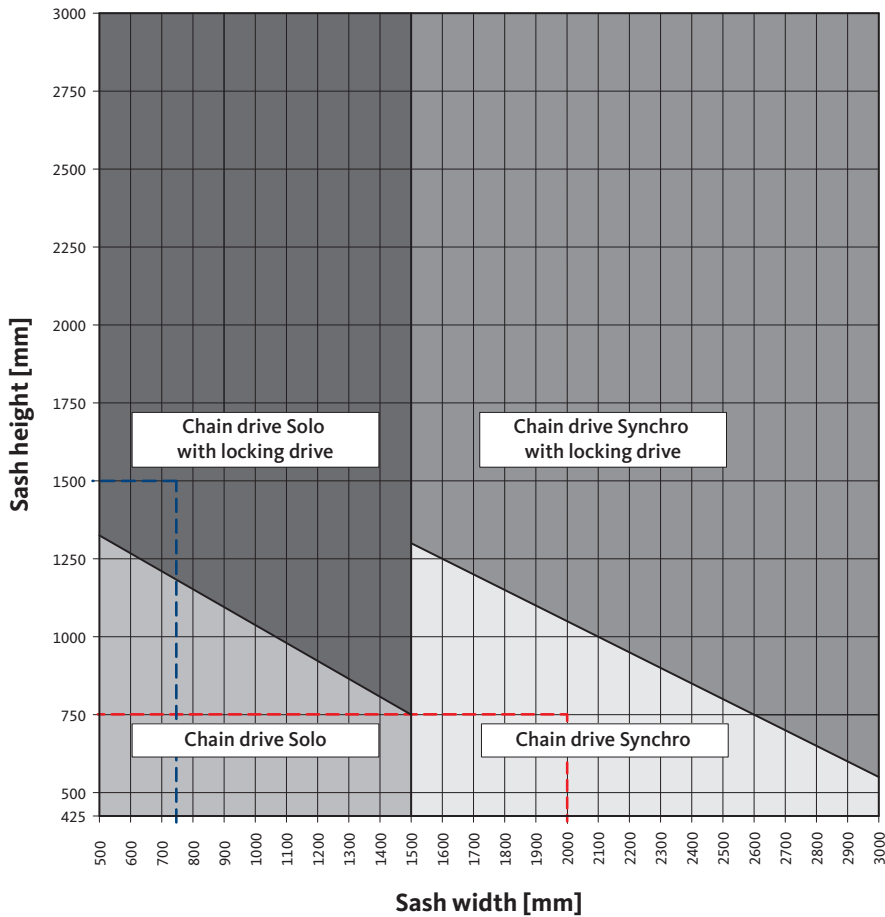

Application ranges

Determination of which drive type to use (Solo/Synchro drive, with or without locking drive) based on the sash width and sash height.

■ **Example 1:**
Bottom-Hung window with the dimensions: 750 x 1500 mm (W x H)
A chain drive Solo with locking drive must be used.

■ **Example 2:**
Bottom-Hung window with the dimensions: 2000 x 750 mm (W x H)
A Synchro chain drive must be used.

All values are reference values which may vary depending on the profile used and the height of the building.
The permissible edge length and the maximum window size must be coordinated with the system provider or the window fabricator.
The instructions of the particular profile system, hardware and glass manufacturers must be observed.
The maximum length of unmounted profile jambs is 1500 mm.

Locking drive ELTRAL VAN

Product characteristics



24V

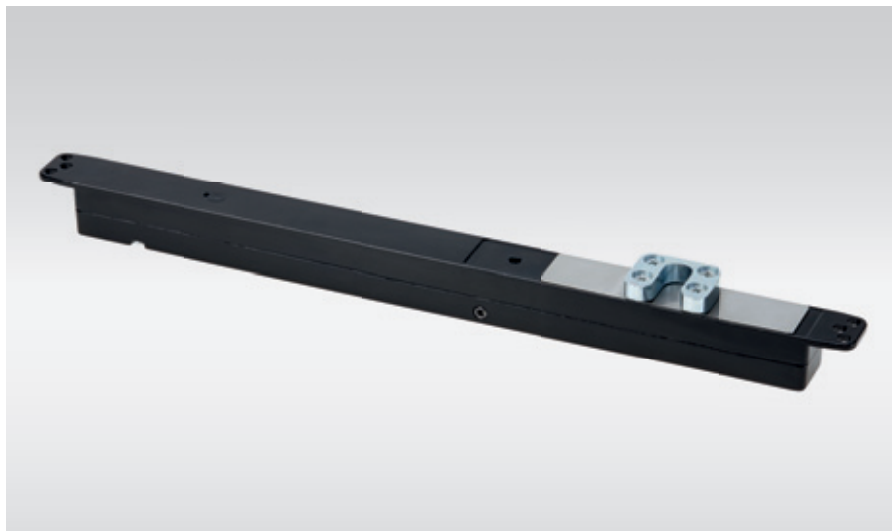

Product characteristics

- Electromotor-driven locking and unlocking by means of the internal central locking system
- Tested and certified in accordance with EN 12101-2
- Compact size
- The integrated microprocessor control ensures the
 - automatic end and overload cut-off
 - closing sequence control
- High break-away force
- Emergency unlocking for opening the central locking system
- Travel adjustment: 18 mm or 35 mm
- Can only be used in combination with the 24-V chain drives ELTRAL K30, KS 30/40 and K35

Dimensions

ELTRAL VAN

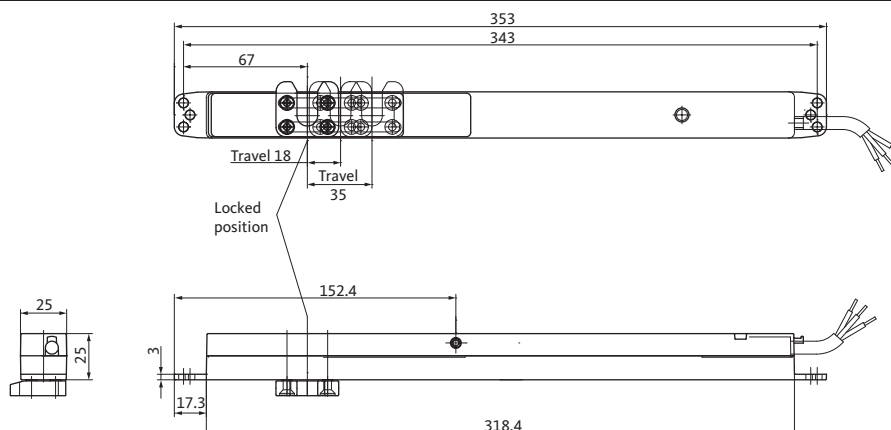

Locking drive ELTRAL VAN

Technical data | Order information



24V

Technical data

Specification	ELTRAL VAN
Nominal voltage	24 V DC
Nominal current	1.5 A
Breaking current	1.5 A
Duty ratio	30 %
Protection code	IP43
Ambient temperature	-5 °C to +60 °C
Max. thrust	600 N
Max. break-away force	850 N
Travel	18/35 mm
Connecting cable	Silicone halogen-free 3 x 0.75 mm ² , ~ 2 m
Dimensions (L x W x H)	353 x 25 x 25 mm

Travel [mm]	Runtime [s]
18	3
35	6

Order information

ELTRAL VAN				
Specification	Finish	PU	Order number	
ELTRAL VAN	Black	1 pc	K-17990-00-0-6	

Contents: 1 x locking drive

Locking drive ELTRAL VAN

Mounting bracket sets – concealed installation

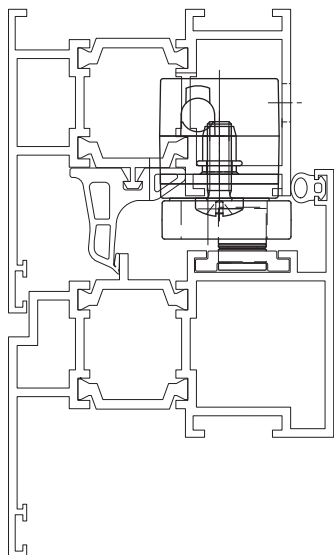

Fixing set VAN

Technical data	
Opening type	Bottom-Hung window Top-Hung window
Type of installation	concealed
Frame material	Aluminium [1] Timber [2]
Min. space requirement	26

Finish	PU	Order number
Silver	1 pc	K-18522-00-0-0

[1] With fixing screws | [2] Without fixing screws

Locking drive ELTRAL VAN

Accessories



Emergency unlocking pin

	PU	Order number
		9-46215-00-0-0
	1 pc	

Dummy plug for emergency unlocking bore

Finish	PU	Order number
		9-45806-00-0-6
Black	1 pc	

Cable sleeve

Finish	PU	Order number
		9-45397-00-0-6
Black	1 pc	

Locking drive FVUI

Product characteristics



24V



Product characteristics

- For controlled natural ventilation, SHEV and NSHEV according to EN 12101-2
- Integrated, intelligent M-COM control electronics with sequential control for S12 drives*
- Suitable for profile-integrated installation in the frame of inward- or outward-opening windows
- Dog made of die-cast zinc
 - actuates multipoint locking systems via an additional locking roller
 - can be mounted on both sides and turned 180°
- Manual emergency unlocking
- Concealed terminal clamps
- Internal push-button for adjusting the running direction
- Rugged corrosion-resistant design
- Slender shortened design of 415 x 26 x 26 mm
- Aluminium body anodised or in RAL colours as option

*For programming of S12 control electronics see page 229.

Locking drive FVUI

Technical data



24V

Technical data

Specification	FVUI 24V DC
Nominal voltage	24 V DC (19 V ... 28 V)
Nominal current	0.6 A
Breaking current	~ 1.0 A
Nominal power	15 W
Duty ratio	5 cycles (ED 30% - ON: 3 min. / OFF: 7 min.)
Protection code	IP32
Ambient temperature	-5 °C to +60 °C
Max. thrust	~ 600 N
Max. break-away force	~ 1000 N
Max. locking force	1500 N
Runtime	~ 5.0 s
Travel	~ 18 mm (± 1)
Connecting cable	halogen-free, grey, Ø 6.2 mm 3 x 0.5 mm ² , ~ 3 m
Dimensions (L x W x H)	415 x 26 x 26 mm
Emission sound pressure level	≤ 70 dB (A)

Locking drive FVUI

Order information – version FVUI 24V DC



24V

Factory condition

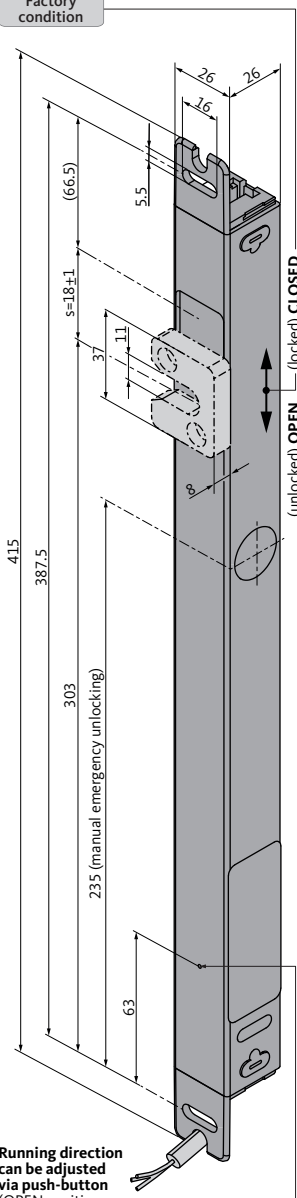



Order information

Specification	Travel [s]	Length [L]	Finish*	PU	Order number
FVUI 24V DC	18 mm	415 mm	EV1	1 pc	515910 

*Drive housing painted in special colour (RAL colour) see page 228.

Special cable lengths

Standard connecting cable length extended to:	Order number
5 m – halogen-free, grey – 3 x 0.5 mm ²	501034 
10 m – halogen-free, grey – 3 x 0.5 mm ²	501036 

Optional accessories

Specification	PU	Order number
M-COM configuration module for interconnected drive systems	1 pc	524177 

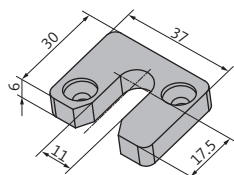

Striker 6 mm

Alternative to striker 8 mm

Surface	Dimensions	PU	Order number
Zinc die-cast	37 x 30 x 6 mm	1 pc	515911 

Locking drive FVUI

Application examples



24V

Application examples

1	2
<p>Profile installation Sash, outward opening Shown on aluminium window</p>	<p>Profile installation Sash, inward-opening Shown on aluminium window</p>

Striker mounting options

Striker is supplied separately (can be installed as option)

Installation example 1	Installation example 2

Locking drive FVUR

Product characteristics



24V



Product characteristics

- For controlled natural ventilation, SHEV and NSHEV according to EN 12101-2
- Integrated, intelligent M-COM control electronics with sequential control for S12 drives*
- Suitable for surface-mounted installation on frame of outward-opening windows or on sash of inward-opening windows
- Stainless steel dog actuates multipoint locking systems via an additional locking roller
- Dog can be adapted to the specific project/profile
- Concealed terminal clamps
- Internal push-button for adjusting the running direction
- Rugged corrosion-resistant design
- Slender shortened design of 415 x 26 x 26 mm
- Aluminium body anodised or in RAL colours as option

*For programming of S12 control electronics see page 229.

Locking drive FVUR

Technical data



24V

Technical data

Specification	FVUR 24V DC
Nominal voltage	24 V DC (19 V ... 28 V)
Nominal current	0.6 A
Breaking current	~ 1.0 A
Nominal power	15 W
Duty ratio	5 cycles (ED 30% - ON: 3 min. / OFF: 7 min.)
Protection code	IP32
Ambient temperature	-5 °C to +60 °C
Max. thrust	~ 600 N
Max. break-away force	~ 1000 N
Max. locking force	1500 N
Runtime	~ 5.0 s
Travel	~ 18 mm (± 1)
Connecting cable	halogen-free, grey, Ø 6.2 mm 3 x 0.5 mm ² , ~ 3 m
Dimensions (L x W x H)	415 x 26 x 26 mm
Emission sound pressure level	≤ 70 dB (A)

Locking drive FVUR

Order information – version FVUR 24V DC



24V

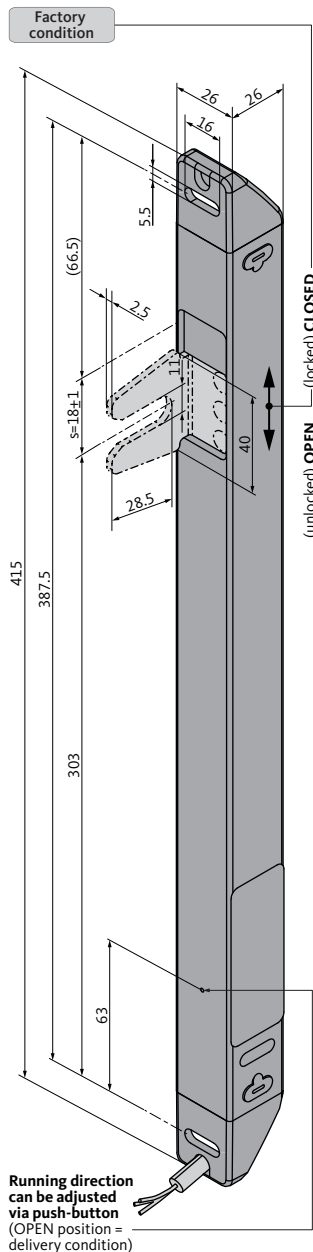



Order information

Specification	Travel [s]	Length [L]	Finish*	PU	Order number
FVUR 24V DC	18 mm	415 mm	EV1	1 pc	515920 

*Drive housing painted in special colour (RAL colour) see page 228.

Special cable lengths



Standard connecting cable length extended to:	Order number
5 m – halogen-free, grey – 3 x 0.5 mm ²	501034 
10 m – halogen-free, grey – 3 x 0.5 mm ²	501036 

Optional accessories

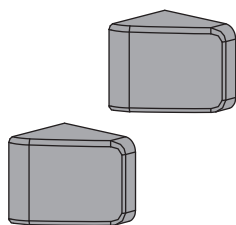
Specification	PU	Order number
M-COM configuration module for interconnected drive systems	1 pc	524177 



PVC cover caps

Finish	PU	Order number
RAL 7035 (light grey)	2 pc	515921 
RAL 9004 (black)	2 pc	515923 

Locking drive FVUR

Application examples



24V

Application examples

1	2
<p>Sash installation Sash, inward-opening Shown on aluminium window</p>	<p>Frame installation Sash, outward opening Shown on aluminium window</p>

Dog mounting options

Dog is supplied separately (can be installed as option)

Installation example 1	Installation example 2
<p>Dog is supplied separately</p>	<p>Dog is supplied separately</p>

Locking drive FVUB

Product characteristics



24V



Product characteristics

- For controlled natural ventilation, SHEV and NSHEV according to EN 12101-2
- Integrated, intelligent M-COM control electronics with sequential control for S12 drives*
- Suitable for installation on frame of inward-opening sashes
- Stainless steel dog actuates multipoint locking systems via an additional locking roller
- Dog can be adapted to the specific project/profile
- Concealed terminal clamps
- Internal push-button for adjusting the running direction
- Rugged corrosion-resistant design
- Slender shortened design of 415 x 26 x 26 mm
- Aluminium body anodised or in RAL colours as option

*For programming of S12 control electronics see page 229.

Locking drive FVUB

Technical data



24V

Technical data

Specification	FVUB 24V DC
Nominal voltage	24 V DC (19 V ... 28 V)
Nominal current	0.6 A
Breaking current	~ 1.0 A
Nominal power	15 W
Duty ratio	5 cycles (ED 30% - ON: 3 min. / OFF: 7 min.)
Protection code	IP32
Ambient temperature	-5 °C to +60 °C
Max. thrust	~ 600 N
Max. break-away force	~ 1000 N
Max. locking force	1500 N
Runtime	~ 5.0 s
Travel	~ 18 mm (± 1)
Connecting cable	halogen-free, grey, Ø 6.2 mm 3 x 0.5 mm ² , ~ 3 m
Dimensions (L x W x H)	415 x 26 x 26 mm
Emission sound pressure level	≤ 70 dB (A)

Locking drive FVUB

Order information – version FVUB 24V DC R



24V

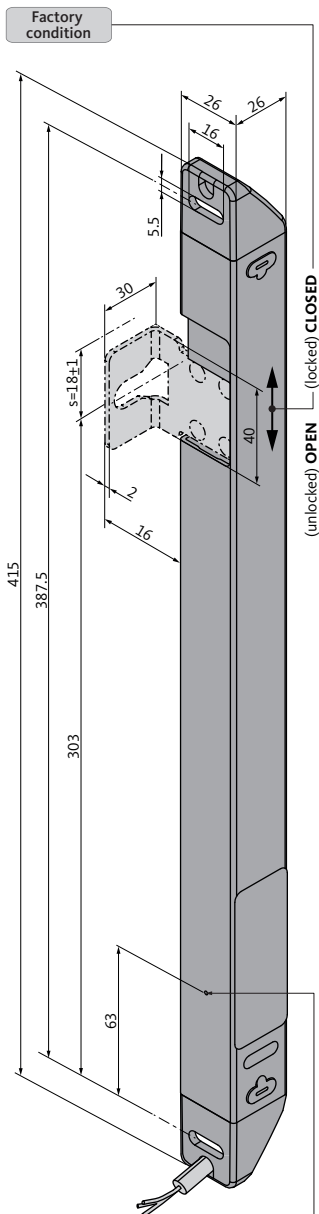



Running direction can be adjusted via push-button (OPEN position = delivery condition)

Order information

Specification	Travel [s]	Length [L]	Finish*	PU	Order number
FVUB 24V DC R	18 mm	415 mm	EV1	1 pc	515930 

*Drive housing painted in special colour (RAL colour) see page 228.

Special cable lengths

Standard connecting cable length extended to:	Order number
5 m – halogen-free, grey – 3 x 0.5 mm ²	501034 
10 m – halogen-free, grey – 3 x 0.5 mm ²	501036 

Optional accessories

Specification	PU	Order number
M-COM configuration module for interconnected drive systems	1 pc	524177 

Dog mounting options

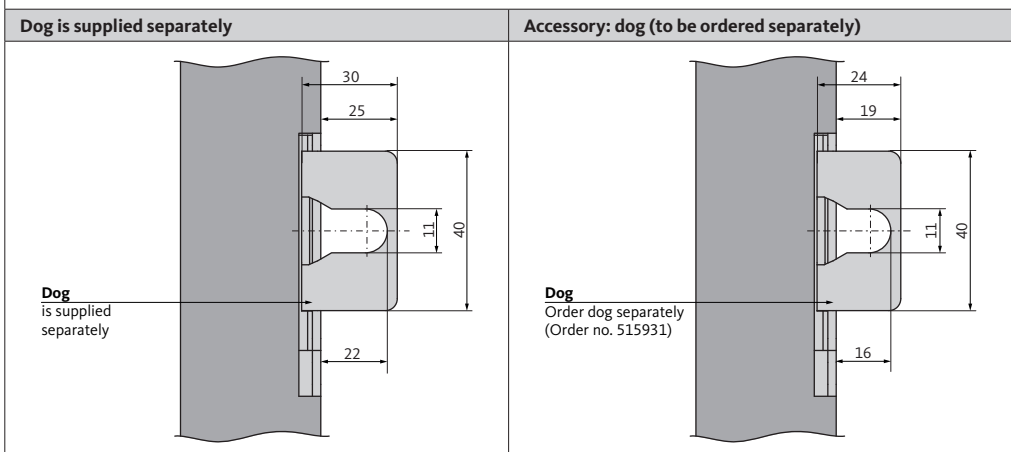

Locking drive FVUB

Order information – version FVUB 24V DC L



24V

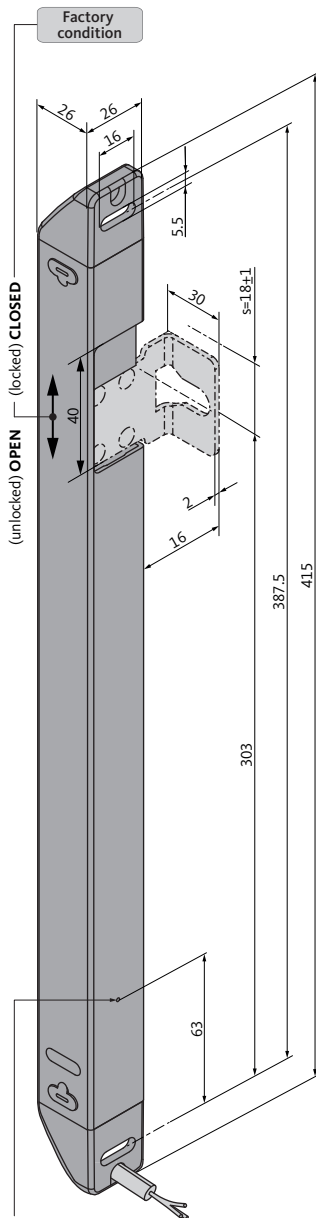



Running direction can be adjusted via push-button (OPEN position = delivery condition)

Order information

Specification	Travel [s]	Length [L]	Finish*	PU	Order number
FVUB 24V DC L	18 mm	415 mm	EV1	1 pc	515940 

*Drive housing painted in special colour (RAL colour) see page 228.

Special cable lengths

Standard connecting cable length extended to:	Order number
5 m – halogen-free, grey – 3 x 0.5 mm ²	501034 
10 m – halogen-free, grey – 3 x 0.5 mm ²	501036 

Optional accessories

Specification	PU	Order number
M-COM configuration module for interconnected drive systems	1 pc	524177 

Dog mounting options

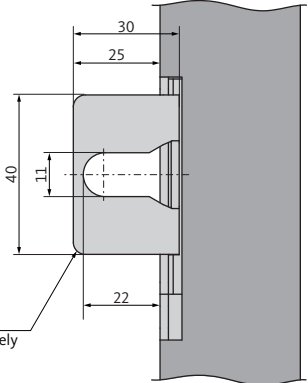
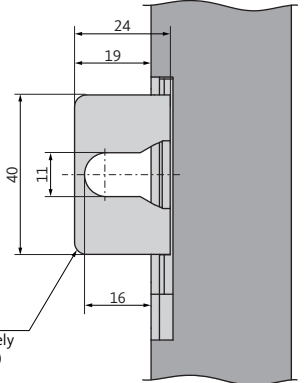
Dog is supplied separately	Accessory: dog (to be ordered separately)
 <p>Dog is supplied separately</p>	 <p>Dog Order dog separately (Order no. 515931)</p>

Locking drive FVUB

Accessories



24V

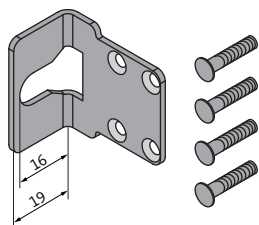



Dog 16 mm

Alternative to 22 mm dog (dog length 25 mm)

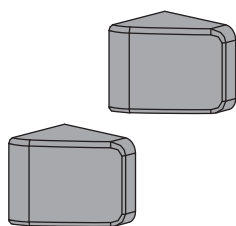
Surface	Dog length	PU	Order number
Stainless steel	19 mm	1 pc	515931 
Contents: 1 x dog, 4 x screw			



PVC cover caps

Finish	PU	Order number
RAL 7035 (light grey)	2 pc	515921 
RAL 9004 (black)	2 pc	515923 

Locking drive FVUB

Application examples



24V

Application examples

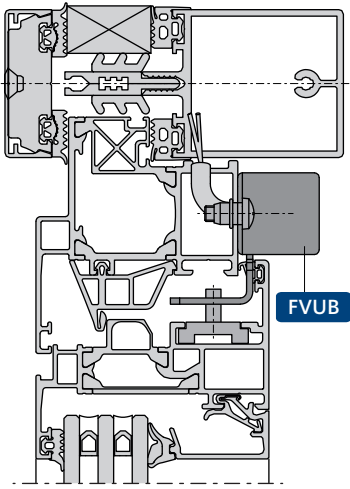
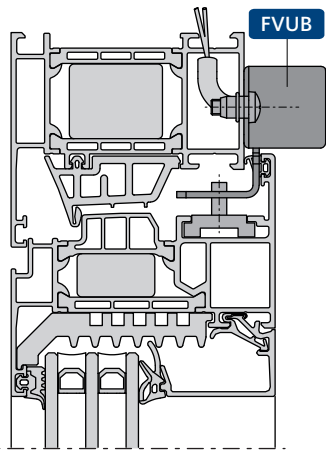
1	2
<p>Frame installation Sash, inward-opening Shown on aluminium window</p>	<p>Frame installation Sash, inward-opening Shown on aluminium window</p>
	

Locking drive OFV

Product characteristics



24V



Product characteristics

- For controlled natural ventilation, SHEV and NSHEV according to EN 12101-2
- Integrated, intelligent M-COM control electronics with sequential control for S12 drives
- Rotation angle can be adjusted to 90°/180°.
- Rotation angle detection, self-learning
- Opening direction adjustable for right/left
- Installation on chamber gear of inward-opening sash instead of window handle
- Dog actuates multipoint locking systems via chamber gear
- Rugged corrosion-resistant design
- Easy to install due to concealed drill holes
- Concealed terminal clamps
- DIP switch for settings
- Plastic housing, grey-white

- Cropping of square spindle according to profile to be provided by customer
- Opening angle preset from factory to 90°

*For programming of S12 control electronics see page 229.

Locking drive OFV

Technical data | Order information



24V

Technical data

Specification	OFV1 M-COM 24V DC
Nominal voltage	24 V DC (19 V ... 28 V)
Nominal current	0.8 A
Breaking current	1.1 A
Fail-safe	< 28 mA (10 Nm)
Nominal power	19 W
Duty ratio	5 cycles (ED 30% - ON: 3 min. / OFF: 7 min.)
Protection code	IP32
Ambient temperature	-5 °C to +60 °C
Torque, max.	10 Nm
Max. blocking moment	22 Nm
Runtime	90° = ~ 4.5 s 180° = ~ 9.0 s
Connecting cable	halogen-free, grey 3 x 0.5 mm ² , ~ 3 m
Dimensions (W x H x D)	40 x 156 x 83.5 mm
Emission sound pressure level	≤ 70 dB (A)

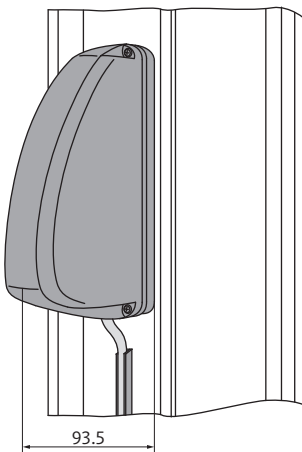
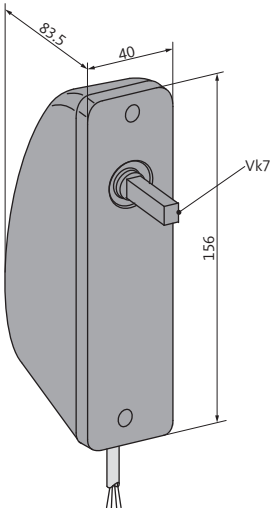

Order information

OFV1 M-COM 24V DC				
Specification	Finish	PU	Order number	
OFV1 M-COM 24V DC	Grey-white	1 pc	513860	
<p>Contents: 1 x locking drive, 1 x adapter plate with Vk 7x55, 2 x M5x40 countersunk screw, 1 x 4.5x30 Spax countersunk screw, 1 x M5x16 countersunk screw, 2 x M5x16 lens screw, 2 x spring ring, 1 x warning sticker</p>				

Optional accessories

Specification	PU	Order number	
M-COM configuration module for interconnected drive systems	1 pc	524177	





1.3 Spindle drives 24 V DC / 230 V AC

Spindle drive PLA	138
Spindle drive PLS	154
Spindle drive SP	170

Spindle drives

Application ranges



The spindle drives from the Gretsch-Unitas group are perfectly suited to opening and closing large and heavy skylights or facade openings.

Regardless of whether the drives are used in shopping centres, theatre foyers, airport terminals or conservatories – in the event of a fire they ensure fast and natural smoke exhaust. In everyday life, the drives provide a healthy and agreeable room climate through automatic air supply and ventilation.

They are particularly important for operating heavy skylights and light domes, where strong pushing forces are required together with large opening widths. A further benefit lies in the high protection class and therefore weather-resistant application.

For very wide and heavy skylights, the intelligent, integrated technology also enables synchronous control of up to eight spindle drives.

Spindle drives

Application ranges



Installation options: spindle drives PLA and PLS

Roof-mounted Bottom-Hung sash

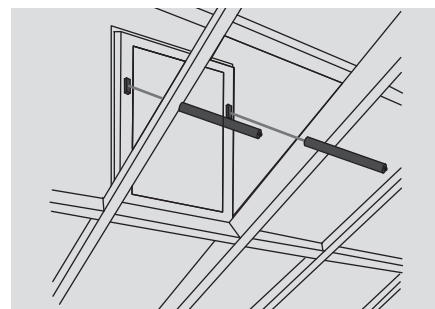
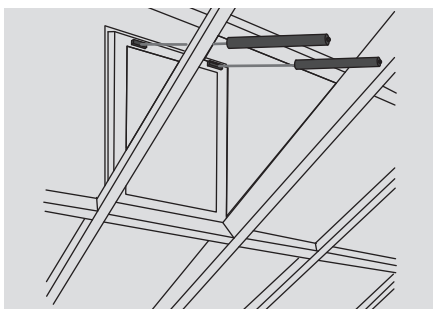
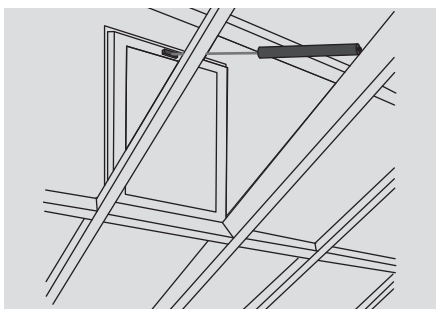

Roof-mounted Top-Hung sash

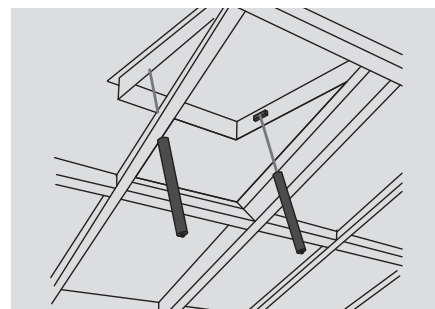
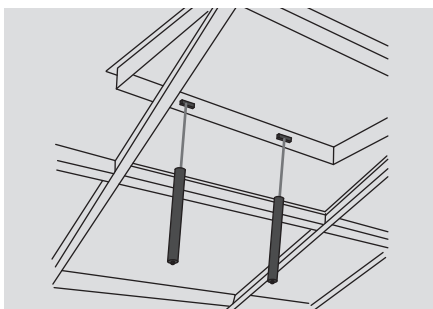
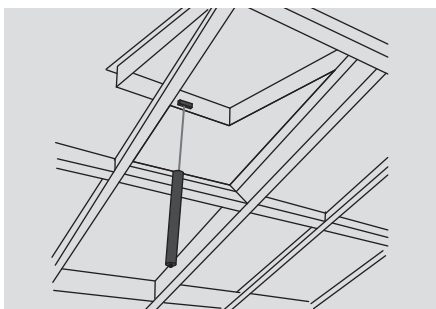

Installation options: spindle drives SP

Roof-mounted Bottom-Hung sash

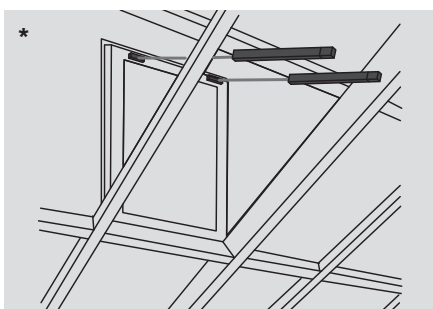
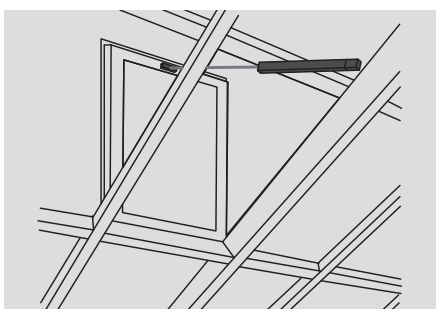

Roof-mounted Top-Hung sash

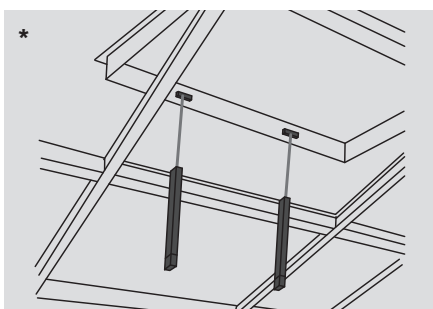
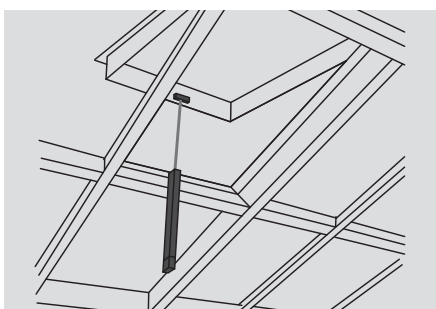

*Running monitoring device for tandem operation for < 300 mm travel with inspection module USKM (ordering no. 512140)

Spindle drive PLA

Product characteristics



24V

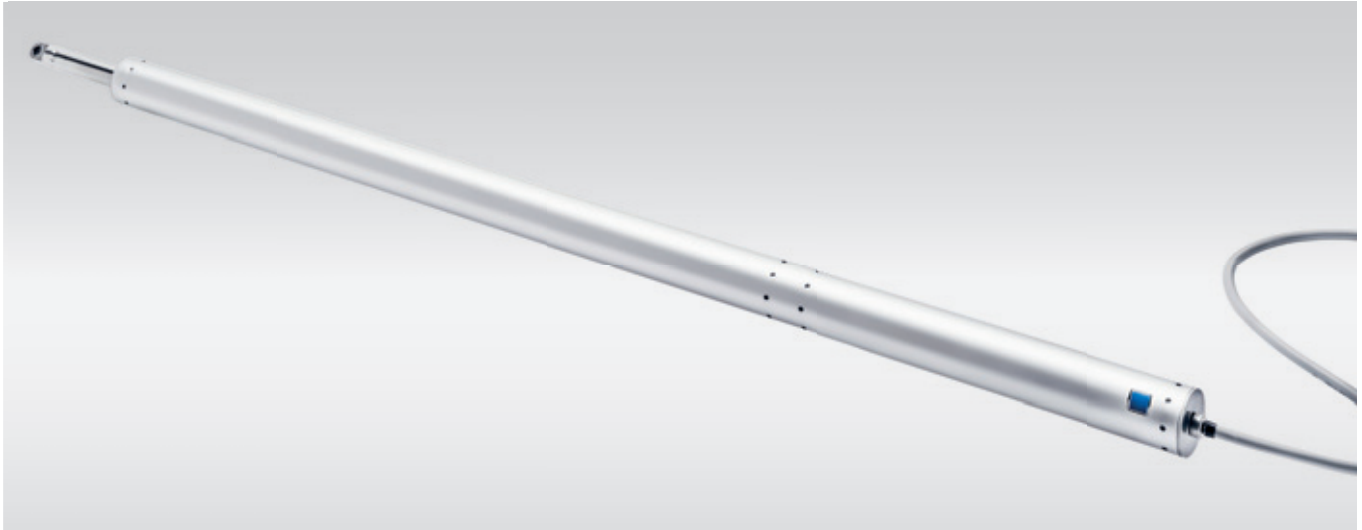

Product characteristics

- For controlled natural ventilation, SHEV and NSHEV according to EN 12101-2
- Easy to install with adjustable clamping ring and rear suspension bracket
- Ball-bearing mounted spindle with end position damping
- Programmable parameters of the intelligent S12 control electronics*
 - Synchronised multiple operation and sequential control
 - Soft start and soft stop at the end positions
 - Travel, closing force, speed
 - Reversing in the event of overload cut-off during the closing operation
- Suitable for operation with M-COM for automatic configuration of synchronous running and sequential controls
- Stainless steel thrust tube
- Rugged corrosion-resistant design
- Aluminium body anodised or in RAL colours as option
- Slender design with 36 mm diameter
- With GoreTex membrane

*For programming of S12 control electronics see page 229.

Spindle drive PLA

Technical data



24V

Technical data

Specification	24 V DC	
	PLA8 S12 24V DC	PLA10 S12 24V DC
Nominal voltage	24 V DC (19 V ... 28 V)	24 V DC (19 V ... 28 V)
Nominal current	1.0 A	1.9 A
Breaking current	1.4 A	2.5 A
Nominal power	24 W	45 W
Duty ratio	5 cycles (ED 30% - ON: 3 min. / OFF: 7 min.)	5 cycles (ED 30% - ON: 3 min. / OFF: 7 min.)
Protection code	IP65	IP65
Ambient temperature	-5 °C to +60 °C	-5 °C to +60 °C
Max. pulling force	800 N	1000 N
Max. locking force	5000 N [1]	5000 N [1]
Connecting cable	halogen-free, grey 3 x 1.0 mm ² , ~ 3 m	halogen-free, grey 3 x 1.0 mm ² , ~ 3 m
Speed	OPEN: 10.0 mm/s CLOSED: 10.0 mm/s	OPEN: 12.6 mm/s CLOSED: 12.6 mm/s
Max. travel	1200 mm	1200 mm
Total length	see order information	
Emission sound pressure level	≤ 70 dB (A)	

[1] depends on fixing

Thrust with reference to travel

PLA8 S12 24V DC

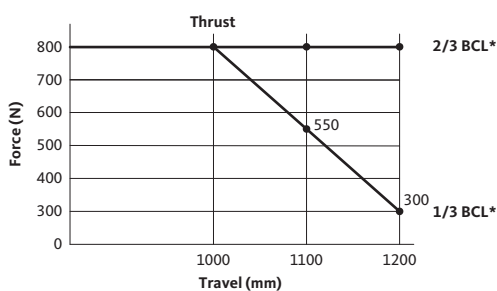

PLA10 S12 24V DC

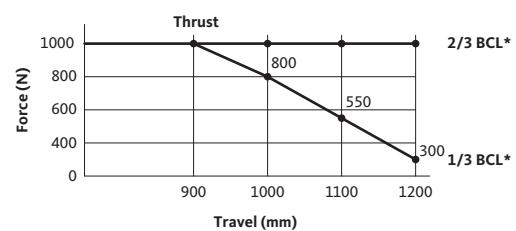

*BCL = Bracket clamping area

Spindle drive PLA







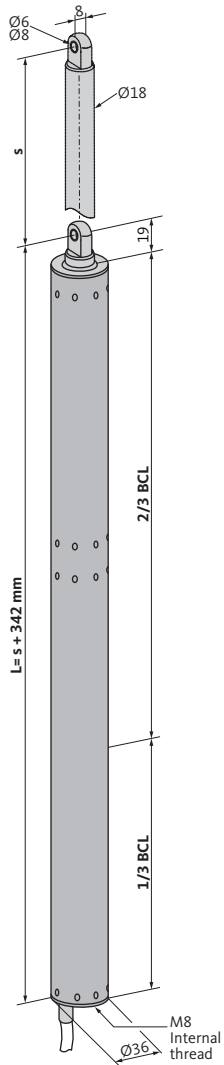

Order information – version PLA8 S12 24V DC



24V





Order information

Specification	PLA8 S12 24V DC				
	Travel [s]	Length [L]	Finish*	PU	Order number
PLA8 100 S12	100 mm	442 mm	EV1	1 pc	515210 
PLA8 200 S12	200 mm	542 mm	EV1	1 pc	515220 
PLA8 300 S12	300 mm	642 mm	EV1	1 pc	515230 
PLA8 400 S12	400 mm	742 mm	EV1	1 pc	515240 
PLA8 500 S12	500 mm	842 mm	EV1	1 pc	515250 
PLA8 600 S12	600 mm	942 mm	EV1	1 pc	515260 
PLA8 750 S12	750 mm	1092 mm	EV1	1 pc	515275 
PLA8 1000 S12	1000 mm	1342 mm	EV1	1 pc	515295 

*Drive housing painted in special colour (RAL colour) see page 228.

Special cable lengths

Standard connecting cable length extended to:	Order number
5 m – halogen-free, grey – 3 x 1.0 mm ²	501037 
10 m – halogen-free, grey – 3 x 1.0 mm ²	501039 

Optional accessories

Specification	PU	Order number
M-COM configuration module for interconnected drive systems	1 pc	524177 

Spindle drive PLA







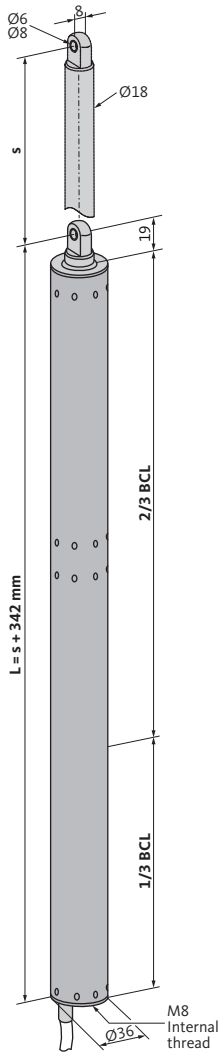

Order information – version PLA10 S12 24V DC



24V





Order information

Specification	PLA10 S12 24V DC				
	Travel [s]	Length [L]	Finish*	PU	Order number
PLA10 100 S12	100 mm	442 mm	EV1	1 pc	523610 
PLA10 200 S12	200 mm	542 mm	EV1	1 pc	523620 
PLA10 300 S12	300 mm	642 mm	EV1	1 pc	523630 
PLA10 400 S12	400 mm	742 mm	EV1	1 pc	523640 
PLA10 500 S12	500 mm	842 mm	EV1	1 pc	523650 
PLA10 600 S12	600 mm	942 mm	EV1	1 pc	523660 
PLA10 750 S12	750 mm	1092 mm	EV1	1 pc	523675 
PLA10 1000 S12	1000 mm	1342 mm	EV1	1 pc	523700 

*Drive housing painted in special colour (RAL colour) see page 228.

Special cable lengths

Standard connecting cable length extended to:	Order number
5 m – halogen-free, grey – 3 x 1.0 mm ²	501037 
10 m – halogen-free, grey – 3 x 1.0 mm ²	501039 

Optional accessories

Specification	PU	Order number
M-COM configuration module for interconnected drive systems	1 pc	524177 

Spindle drive PLA

Fixings – overview



Overview of fixings

Example of application				1	2	5	6	7	8	9	
Mounting bracket				K5	K5	K82	K122	K127	K122-1	K122-1	
Fixing accessories				B4							
Chain holding fixture				F29-1	F10.6 F11 F40	F10.6 F11 F40	F29	F11	F36	F30	
Profile system				Heraol 085D	-	-	Heraol 085D	Raico Wing 105D	Schüco AWS 57RO	Wicona Wictec 50	
Space requirement min. [mm]				50	50	45	60	35	68	68	
Sash material				Aluminium	■	■	■	■	■	■	
				Timber	-	■	■	-	-	-	-
				PVC	-	■	■	-	-	-	-
Sash and assembly type	Roof	outward	MCE	FI	■	-	■	-	-	-	
				SI	-	■	-	-	-	-	
			SCE	FI	-	-	-	■	■	■	■
				SI	-	■	-	-	-	-	-
ESW [1]				Solo [mm]		450 – 1300					
				Sync2 [mm]		1200 – 2400					
ESH [1]				Solo [mm]		450 – 1500					
				Sync2 [mm]		450 – 2500					

[1] The instructions of the particular profile system, hardware and glass manufacturers must be observed. The specifications for ESW/ESH apply accordingly for Side-Hung sashes.

Spindle drive PLA

Fixings – application examples



Application examples

<p style="text-align: center;">1</p>	<p style="text-align: center;">2</p>	<p style="text-align: center;">5</p>
<p>Installation on frame, main closing edge, outward-opening roof window Shown on aluminium window</p>	<p>Installation on frame, main closing edge, outward-opening roof window Shown on aluminium window</p>	<p>Installation on frame, main closing edge, outward-opening roof window Shown on aluminium window</p>
<p style="text-align: center;">6</p>	<p style="text-align: center;">7</p>	<p style="text-align: center;">8</p>
<p>Installation on frame, secondary closing edge, outward-opening roof window Shown on aluminium window</p>	<p>Installation on frame, secondary closing edge, outward-opening roof window Shown on aluminium window</p>	<p>Installation on frame, secondary closing edge, outward-opening roof window Shown on aluminium window</p>
<p style="text-align: center;">9</p>		
<p>Installation on frame, secondary closing edge, outward-opening roof window Shown on aluminium window</p>		

Spindle drive PLA

Fixings – chain holding fixtures – surface-mounted installation

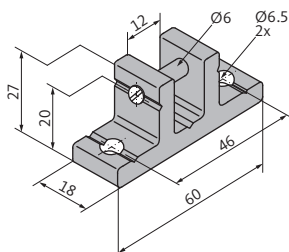

Chain holding fixture F10.6

Application

- Surface-mounted installation on main closing edge of outward-opening roof window sashes
- For spindle drives with front or rear mounting
- Drill hole Ø 6 mm
- Stud bolt, screwable
- Max. load 1600 N

Finish*	PU	Order number	
Aluminium (EV1)	1 pc	151000	
Contents: 1 x chain holding fixture, 1 x stud bolt Ø 6 mm			

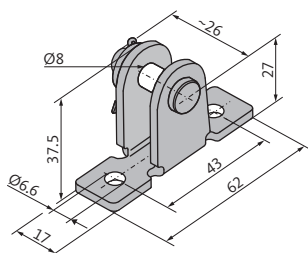

Chain holding fixture F11

Application

- Surface-mounted installation on secondary closing edge of sashes or frames of outward-opening roof windows
- For spindle drives with front or rear mounting
- Drill hole Ø 8 mm
- Max. load 3000 N

Finish*	PU	Order number	
Steel, galvanised (F11ST)	1 pc	151400	
Contents: 1 x chain holding fixture, 1 x pin Ø 8 mm, 1 x washer, 1 x split pin			

*Chain holding fixtures painted/powder-coated in special colour (RAL colour) see page 228.

Spindle drive PLA

Fixings – chain holding fixtures – surface-mounted installation

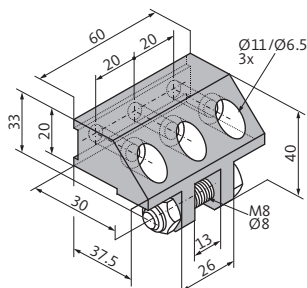

Chain holding fixture F40

Application

- Surface-mounted installation on main closing edge of outward-opening roof window sashes
- For spindle drives with front or rear mounting
- Drill hole Ø 8 mm

Finish*	PU	Order number	
Aluminium (EV1)	1 pc	155172	
Contents: 1 x chain holding fixture, 1 x M8x35 screw, 1 x M8 nut			

*Chain holding fixtures painted/powder-coated in special colour (RAL colour) see page 228.

Spindle drive PLA

Fixings – mounting brackets – surface-mounted installation

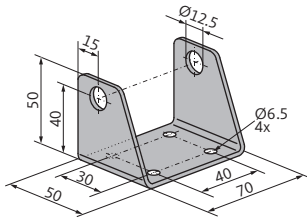

K5 mounting bracket

Application

- Surface-mounted installation on main closing edge of the frame of outward-opening roof windows
- For swivel-mounting of spindle drives PLA
- In combination with clamping ring B4**
- Drill holes Ø 12.5 mm

Finish*	PU	Order number	
Galvanised steel	1 pc	155800	
Contents: 1 x mounting bracket			

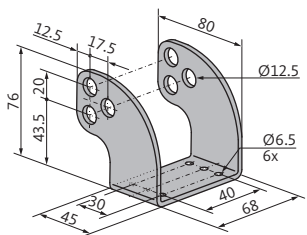

K82 mounting bracket

Application

- Surface-mounted installation on main closing edge of the frame of outward-opening roof windows
- For swivel-mounting of spindle drives PLA
- In combination with clamping ring B4**
- Drill holes Ø 12.5 mm

Finish*	PU	Order number	
Stainless steel	1 pc	151320	
Contents: 1 x mounting bracket			

*Mounting brackets painted/powder-coated in special colour (RAL colour) see page 228.

**Not included in the scope of delivery.

Spindle drive PLA

Fixings – accessories

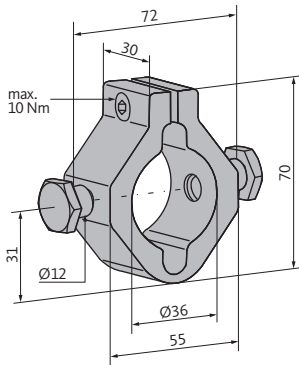

Clamping ring B4

Application

- Adjustable clamp fastening on PLA drive housing
- For surface-mounted installation with swivel mount
- In combination with mounting brackets K5, K82, K122, K122-1, K127

Finish*	PU	Order number
Aluminium (uncoated), stainless steel	1 pc	515900 
Contents: 1 x clamping ring, 2 x flange bolt B8 (Ø 12 mm, G1/8), 1 x M6x16 cheese-head screw		

Spindle drive PLA

Fixings – specific applications – main closing edge
Schüco AWS 57RO, Wicona Wictec 50, Raico Wing 105D

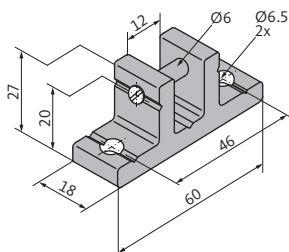

Chain holding fixture F10.8S

Application

- Surface-mounted installation on main closing edge of outward-opening roof window sashes
- For spindle drives with front or rear mounting
- Drill hole \varnothing 8 mm
- Max. load 3000 N

Finish*	PU	Order number	
Aluminium	1 pc	151105	
Contents: 1 x chain holding fixture, 1 x M8 nut, 1 x M8x35 screw			

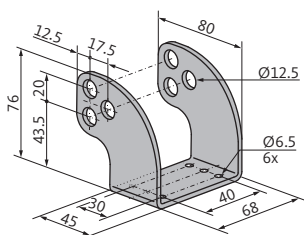

K82 mounting bracket

Application

- Surface-mounted installation on main closing edge of the frame of outward-opening roof windows
- For swivel-mounting of spindle drives PLA
- In combination with clamping ring B4**
- Drill holes \varnothing 12.5 mm

Finish*	PU	Order number	
Stainless steel	1 pc	151320	
Contents: 1 x mounting bracket			

Spindle drive PLA

Fixings – specific applications – secondary closing edge
Schüco AWS 57RO

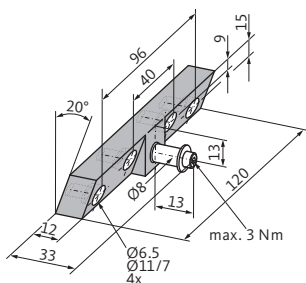

Chain holding fixture F36

Application

- Surface-mounted installation on secondary closing edge of sashes of outward-opening roof windows
- For spindle drives with front mounting
- Drill hole \varnothing 8 mm

Finish*	PU	Order number	
Aluminium (EV1), stainless steel	1 pc	155170	
Contents: 1 x chain holding fixture, 1 x pin \varnothing 8 mm, 1 x M4 screw, 1 x washer A4.3			

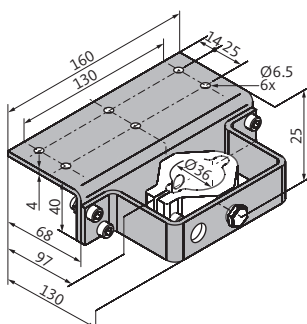

Mounting bracket K122-1

Application

- Surface-mounted installation on secondary closing edge of frames of outward-opening roof windows
- For swivel-mounting of spindle drives PLA
- In combination with clamping ring B4**

Finish*	PU	Order number	
Stainless steel	1 pc	155116	
Contents: 1 x mounting bracket			

*Chain holding fixtures/mounting brackets painted/powder-coated in special colour (RAL colour) see page 228. | **Not included in the scope of delivery.

Spindle drive PLA

Fixings – specific applications – secondary closing edge
Wicona Wictec 50

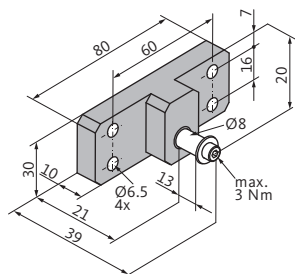

Chain holding fixture F30

Application

- Surface-mounted installation on secondary closing edge of sashes of outward-opening roof windows
- For spindle drives with front mounting
- Drill hole Ø 8 mm

Finish*	PU	Order number	
Aluminium (EV1), stainless steel	1 pc	155160	
Contents: 1 x chain holding fixture, 1 x pin Ø 8 mm, 1 x M4 screw, 1 x washer A4.3			

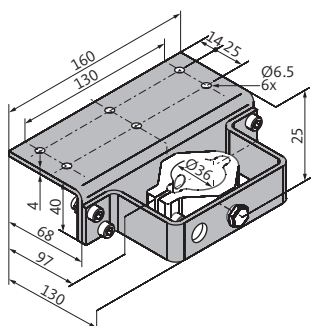

Mounting bracket K122-1

Application

- Surface-mounted installation on secondary closing edge of frames of outward-opening roof windows
- For swivel-mounting of spindle drives PLA
- In combination with clamping ring B4**

Finish*	PU	Order number	
Stainless steel	1 pc	155116	
Contents: 1 x mounting bracket			

*Chain holding fixtures/mounting brackets painted/powder-coated in special colour (RAL colour) see page 228. | **Not included in the scope of delivery.

Spindle drive PLA

Fixings – specific applications – secondary closing edge
Raico Wing 105D

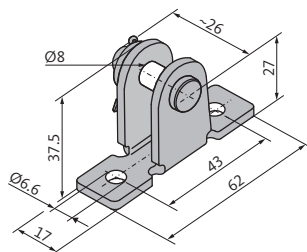

Chain holding fixture F11

Application

- Surface-mounted installation on secondary closing edge of sashes or frames of outward-opening roof windows
- For spindle drives with front or rear mounting
- Drill hole Ø 8 mm
- Max. load 3000 N

Finish*	PU	Order number	
Steel, galvanised (F11ST)	1 pc	151400	
Stainless steel (F11VA)	1 pc	151401	

Contents: 1 x chain holding fixture, 1 x pin Ø 8 mm, 1 x washer, 1 x split pin

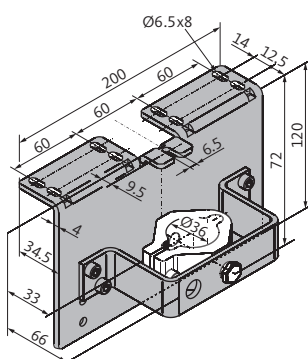

K127 mounting bracket

Application

- Surface-mounted installation on secondary closing edge of frames of outward-opening roof windows
- For swivel-mounting of spindle drives PLA
- In combination with clamping ring B4**

Finish*	PU	Order number	
Stainless steel	1 pc	155119	

Contents: 1 x mounting bracket

Spindle drive PLA

Fixings – specific applications – main closing edge
Heraol 085D

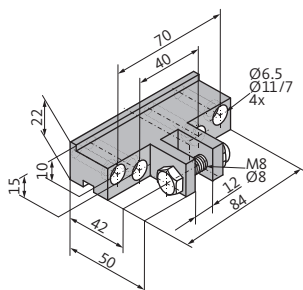

Chain holding fixture F29-1

Application

- Surface-mounted installation on main closing edge of outward-opening roof window sashes
- For spindle drives with front mounting
- Drill hole \varnothing 8 mm

Finish*	PU	Order number	
Aluminium (EV1), stainless steel	1 pc	155158	
Contents: 1 x chain holding fixture, 1 x M8x35 screw, 1 x M8 nut			

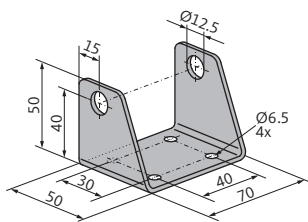

K5 mounting bracket

Application

- Surface-mounted installation on main closing edge of the frame of outward-opening roof windows
- For swivel-mounting of spindle drives PLA
- In combination with clamping ring B4**
- Drill holes \varnothing 12.5 mm

Finish*	PU	Order number	
Galvanised steel	1 pc	155800	
Contents: 1 x mounting bracket			

Spindle drive PLA

Fixings – specific applications – secondary closing edge
Heraol 085D

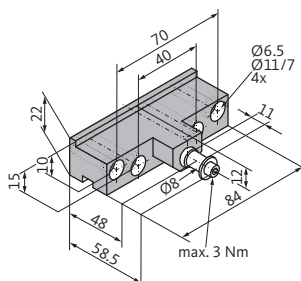

Chain holding fixture F29

Application

- Surface-mounted installation on secondary closing edge of sashes of outward-opening roof windows
- For spindle drives with front mounting
- Drill hole \varnothing 8 mm

Finish*	PU	Order number	
Aluminium (EV1), stainless steel	1 pc	155156	
Contents: 1 x chain holding fixture, 1 x pin \varnothing 8 mm, 1 x M4 screw, 1 x washer A4.3			

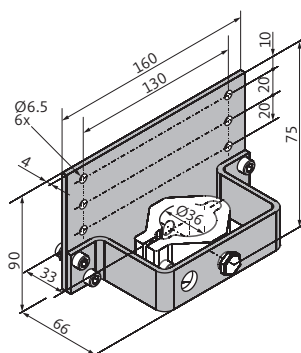

K122 mounting bracket

Application

- Surface-mounted installation on secondary closing edge of frames of outward-opening roof windows
- For swivel-mounting of spindle drives PLA
- In combination with clamping ring B4**

Finish*	PU	Order number	
Stainless steel	1 pc	155115	
Contents: 1 x mounting bracket			

Spindle drive PLS

Product characteristics



24V

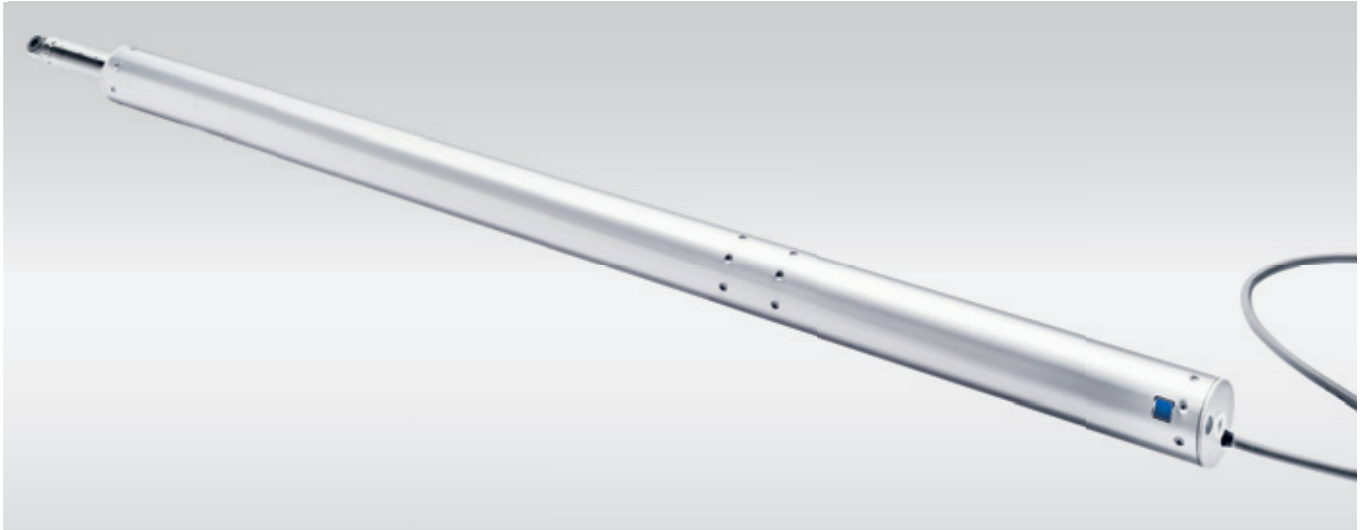

Product characteristics

- For controlled natural ventilation, SHEV and NSHEV according to EN 12101-2
- Easy to install with adjustable clamping ring (rear mounting on request)
- Ball-bearing mounted spindle with end position damping
- Programmable parameters of the intelligent S12 control electronics*
 - Synchronised multiple operation and sequential control
 - Soft start and soft stop at the end positions
 - Travel, closing force, speed
 - Reversing in the event of overload cut-off during the closing operation
- Suitable for operation with M-COM for automatic configuration of synchronous running and sequential controls
- Stainless steel thrust tube
- Rugged corrosion-resistant design
- Aluminium body anodised or in RAL colours as option
- With GoreTex membrane

*For programming of S12 control electronics see page 229.

Spindle drive PLS

Technical data



24V

Technical data

Specification	24 V DC
	PLS15 S12 24V DC
Nominal voltage	24 V DC (19 V ... 28 V)
Nominal current	3.0 A
Breaking current	4.0 A
Nominal power	72 W
Duty ratio	5 cycles (ED 30% - ON: 3 min. / OFF: 7 min.)
Protection code	IP54
Ambient temperature	-5 °C to +60 °C
Max. pulling force	1500 N
Max. locking force	25000 N [1]
Connecting cable	halogen-free, grey 3 x 1.0 mm ² , ~ 3 m
Speed	OPEN: 16.0 mm/s CLOSED: 16.0 mm/s
Max. travel	1200 mm
Total length	see order information
Emission sound pressure level	≤ 70 dB (A)

[1] depends on fixing

Thrust with reference to travel

PLS15 S12 24V DC

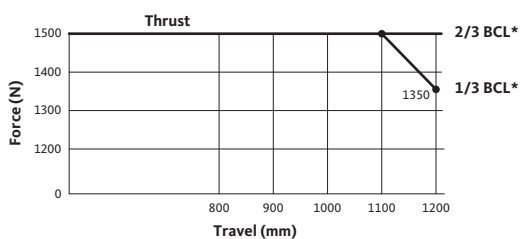

*BCL = Bracket clamping area

Spindle drive PLS





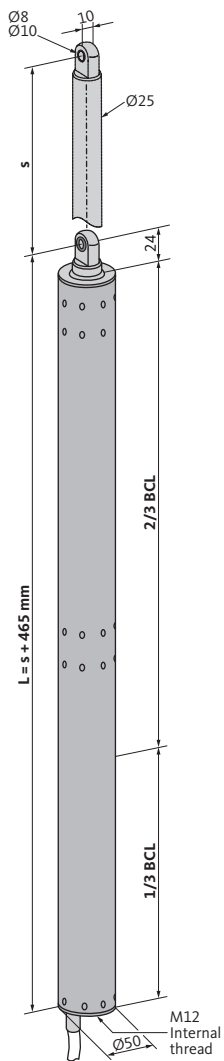

Order information – version PLS15 S12 24V DC



24V





Order information

Specification	PLS15 S12 24V DC				
	Travel [s]	Length [L]	Finish*	PU	Order number
PLS15 300 S12	300 mm	765 mm	EV1	1 pc	576830 
PLS15 400 S12	400 mm	865 mm	EV1	1 pc	576840 
PLS15 500 S12	500 mm	965 mm	EV1	1 pc	576850 
PLS15 600 S12	600 mm	1065 mm	EV1	1 pc	576860 
PLS15 750 S12	750 mm	1215 mm	EV1	1 pc	576875 
PLS15 1000 S12	1000 mm	1465 mm	EV1	1 pc	576800 
PLS15 1200 S12	1200 mm	1665 mm	EV1	1 pc	576812 

*Drive housing painted in special colour (RAL colour) see page 228.

Special cable lengths

Standard connecting cable length extended to:	Order number
5 m – halogen-free, grey – 3 x 1.0 mm ²	501037 
10 m – halogen-free, grey – 3 x 1.0 mm ²	501039 

Optional accessories

Specification	PU	Order number
M-COM configuration module for interconnected drive systems	1 pc	524177 



Spindle drive PLS

Fixings – overview



Overview of fixings

Example of application				1	2	3	4	5	6	7	
Mounting bracket				K70	K82-1	K82-1	K121	K127-1	K121-1	K121-1	
Fixing accessories				B6							
Chain holding fixture				F10.10	F10.10	F28-1	F28	F10.11	F36	F30	
Profile system				Wicona Wictec 50 Raico Wing 105D	Schüco AWS 57RO Raico Wing 105D	Heroal 085D	Heroal 085D	Skylight	Schüco AWS 57RO	Wicona Wictec 50	
Space requirement		min. [mm]		120	50	50	35	35	50	50	
Sash material		Aluminium		■	■	■	■	■	■	■	
		Timber		■	■	-	-	-	-	-	
		PVC		■	■	-	-	-	-	-	
Sash and assembly type	Roof	outward	MCE	FI	■	■	■	-	-	-	
				SI	-	-	-	-	-	-	
			SCE	FI	-	-	-	■	■	■	■
				SI	-	-	-	-	-	-	-
ESW [1]	Solo [mm]		450 – 1300								
	Sync2 [mm]		1200 – 2500								
ESH [1]	Solo [mm]		450 – 1500								
	Sync2 [mm]		450 – 2500								

[1] The instructions of the particular profile system, hardware and glass manufacturers must be observed. The specifications for ESW/ESH apply accordingly for Side-Hung sashes.

Spindle drive PLS

Fixings – application examples



Application examples

<p style="text-align: center;">1</p>	<p style="text-align: center;">2</p>	<p style="text-align: center;">3</p>
<p>Installation on frame, main closing edge, outward-opening roof window Shown on aluminium window</p>	<p>Installation on frame, main closing edge, outward-opening roof window Shown on aluminium window</p>	<p>Installation on frame, main closing edge, outward-opening roof window Shown on aluminium window</p>
<p style="text-align: center;">4</p>	<p style="text-align: center;">5</p>	<p style="text-align: center;">6</p>
<p>Installation on frame, secondary closing edge, outward-opening roof window Shown on aluminium window</p>	<p>Installation on frame, secondary closing edge, outward-opening roof window Shown on aluminium window</p>	<p>Installation on frame, secondary closing edge, outward-opening roof window Shown on aluminium window</p>
<p style="text-align: center;">7</p>		
<p>Installation on frame, secondary closing edge, outward-opening roof window Shown on aluminium window</p>		

Spindle drive PLS

Fixings – chain holding fixtures – surface-mounted installation

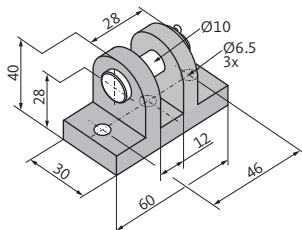

Chain holding fixture F10.10

Application

- Surface-mounted installation on main closing edge of outward-opening roof window sashes
- For spindle drives with front or rear mounting
- Drill hole Ø 10 mm
- Max. load 5000 N

Finish*	PU	Order number	
Aluminium (EV1), stainless steel	1 pc	151201	
Contents: 1 x chain holding fixture, 1 x pin Ø 10 mm, 1 x washer, 1 x split pin			

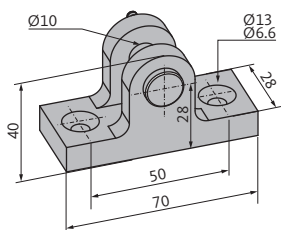

Chain holding fixture F10.11

Application

- Surface-mounted installation on secondary closing edge of sashes or frames of outward-opening roof windows
- For spindle drives with front or rear mounting
- Drill hole Ø 10 mm
- Max. load 5000 N

Finish*	PU	Order number	
Aluminium (EV1), stainless steel	1 pc	151202	
Contents: 1 x chain holding fixture, 1 x pin Ø 10 mm, 1 x washer, 1 x split pin			

*Chain holding fixtures painted/powder-coated in special colour (RAL colour) see page 228.

Spindle drive PLS

Fixings – chain holding fixtures – surface-mounted installation

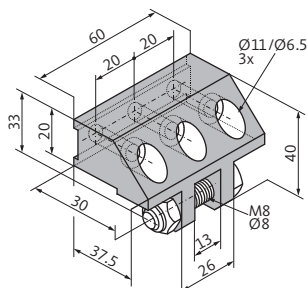

Chain holding fixture F40

Application

- Surface-mounted installation on main closing edge of outward-opening roof window sashes
- For spindle drives with front or rear mounting
- Drill hole Ø 8 mm

Finish*	PU	Order number	
Aluminium (EV1)	1 pc	155172	
Contents: 1 x chain holding fixture, 1 x M8x35 screw, 1 x M8 nut			

*Chain holding fixtures painted/powder-coated in special colour (RAL colour) see page 228.

Spindle drive PLS

Fixings – mounting brackets – surface-mounted installation

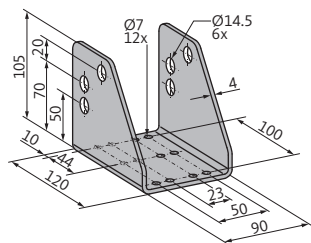

K70 mounting bracket

Application

- Surface-mounted installation on main closing edge of the frame of outward-opening roof windows
- For swivel-mounting of spindle drives PLS
- In combination with clamping ring B6**
- Drill holes Ø 14.5 mm

Finish*	PU	Order number
Galvanised steel	1 pc	155002 
Contents: 1 x mounting bracket		

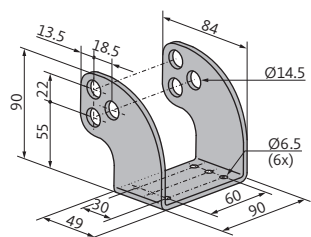

Mounting bracket K82-1

Application

- Surface-mounted installation on main closing edge of the frame of outward-opening roof windows
- For swivel-mounting of spindle drives PLS
- In combination with clamping ring B6**
- Drill holes Ø 14.5 mm

Finish*	PU	Order number
Stainless steel	1 pc	151321 
Contents: 1 x mounting bracket		

*Mounting brackets painted/powder-coated in special colour (RAL colour) see page 228.

**Not included in the scope of delivery.

Spindle drive PLS

Fixings – accessories

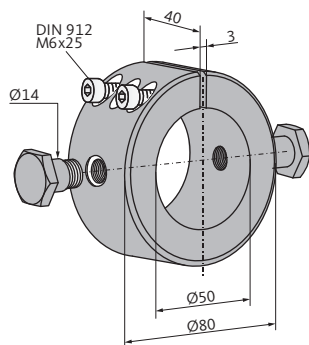

Clamping ring B6

Application

- Adjustable clamp fastening on PLS drive housing
- For surface-mounted installation with swivel mount
- In combination with mounting brackets K70, K82-1, K121, K121-1, K127-1

Finish*	PU	Order number	
Aluminium (uncoated), stainless steel	1 pc	576001	
Contents: 1 x clamping ring, 2 x flange bolt B9 (Ø 14 mm, G1/8), 2 x M6x25 cheese-head screw			

Spindle drive PLS

Fixings – specific applications – main closing edge
Schüco AWS 57RO, Wicona Wictec 50, Raico Wing 105D

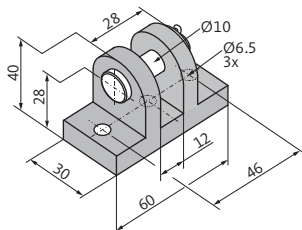

Chain holding fixture F10.10

Application

- Surface-mounted installation on main closing edge of outward-opening roof window sashes
- For spindle drives with front or rear mounting
- Drill hole Ø 10 mm
- Max. load 5000 N

Finish*	PU	Order number
Aluminium (EV1), stainless steel	1 pc	151201
		
Contents: 1 x chain holding fixture, 1 x pin Ø 10 mm, 1 x washer, 1 x split pin		

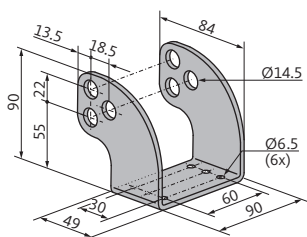

Mounting bracket K82-1

Application

- Surface-mounted installation on main closing edge of the frame of outward-opening roof windows
- For swivel-mounting of spindle drives PLS
- In combination with clamping ring B6**
- Drill holes Ø 14.5 mm

Finish*	PU	Order number
Stainless steel	1 pc	151321
		
Contents: 1 x mounting bracket		

Spindle drive PLS

Fixings – specific applications – secondary closing edge
Schüco AWS 57RO

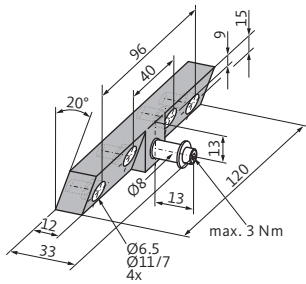

Chain holding fixture F36

Application

- Surface-mounted installation on secondary closing edge of sashes of outward-opening roof windows
- For spindle drives with front mounting
- Drill hole \varnothing 8 mm

Finish*	PU	Order number	
Aluminium (EV1), stainless steel	1 pc	155170	
Contents: 1 x chain holding fixture, 1 x pin \varnothing 8 mm, 1 x M4 screw, 1 x washer A4.3			

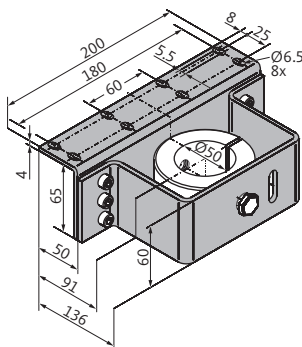

Mounting bracket K121-1

Application

- Surface-mounted installation on secondary closing edge of frames of outward-opening roof windows
- For swivel-mounting of spindle drives PLS
- In combination with clamping ring B6**

Finish*	PU	Order number	
Stainless steel	1 pc	155117	
Contents: 1 x mounting bracket			

*Chain holding fixtures/mounting brackets painted/powder-coated in special colour (RAL colour) see page 228. | **Not included in the scope of delivery.

Spindle drive PLS

Fixings – specific applications – secondary closing edge
Wicona Wictec 50

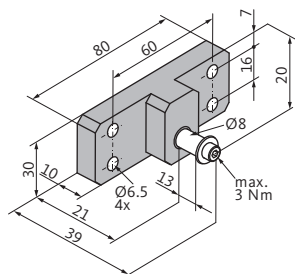

Chain holding fixture F30

Application

- Surface-mounted installation on secondary closing edge of sashes of outward-opening roof windows
- For spindle drives with front mounting
- Drill hole Ø 8 mm

Finish*	PU	Order number	
Aluminium (EV1), stainless steel	1 pc	155160	
Contents: 1 x chain holding fixture, 1 x pin Ø 8 mm, 1 x M4 screw, 1 x washer A4.3			

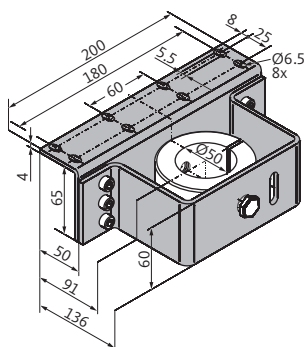

Mounting bracket K121-1

Application

- Surface-mounted installation on secondary closing edge of frames of outward-opening roof windows
- For swivel-mounting of spindle drives PLS
- In combination with clamping ring B6**

Finish*	PU	Order number	
Stainless steel	1 pc	155117	
Contents: 1 x mounting bracket			

*Chain holding fixtures/mounting brackets painted/powder-coated in special colour (RAL colour) see page 228. | **Not included in the scope of delivery.

Spindle drive PLS

Fixings – specific applications – secondary closing edge
Raico Wing 105D

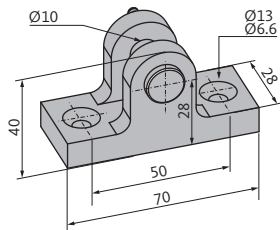

Chain holding fixture F10.11

Application

- Surface-mounted installation on secondary closing edge of sashes or frames of outward-opening roof windows
- For spindle drives with front or rear mounting
- Drill hole \varnothing 10 mm
- Max. load 5000 N

Finish*	PU	Order number	
Aluminium (EV1), stainless steel	1 pc	151202	
Contents: 1 x chain holding fixture, 1 x pin \varnothing 10 mm, 1 x washer, 1 x split pin			

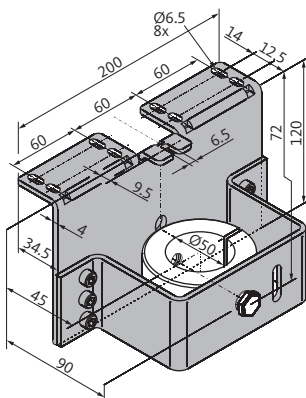

Mounting bracket K127-1

Application

- Surface-mounted installation on secondary closing edge of frames of outward-opening roof windows
- For swivel-mounting of spindle drives PLS
- In combination with clamping ring B6**

Finish*	PU	Order number	
Stainless steel	1 pc	155118	
Contents: 1 x mounting bracket			

Spindle drive PLS

Fixings – specific applications – main closing edge
Heraol 085D

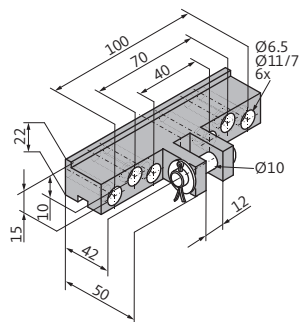

Chain holding fixture F28-1

Application

- Surface-mounted installation on main closing edge of outward-opening roof window sashes
- For spindle drives with front mounting
- Drill hole Ø 10 mm

Finish*	PU	Order number
Aluminium (EV1), stainless steel	1 pc	155154 
Contents: 1 x chain holding fixture, 1 x pin Ø 10 mm, 1 x M5 screw, 1 x A5.3 washer, 1 x 2x20 split pin		

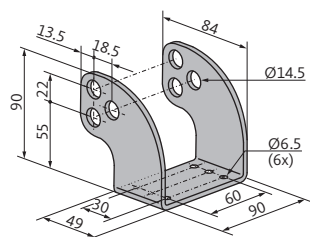

Mounting bracket K82-1

Application

- Surface-mounted installation on main closing edge of the frame of outward-opening roof windows
- For swivel-mounting of spindle drives PLS
- In combination with clamping ring B6**
- Drill holes Ø 14.5 mm

Finish*	PU	Order number
Stainless steel	1 pc	151321 
Contents: 1 x mounting bracket		

*Chain holding fixtures/mounting brackets painted/powder-coated in special colour (RAL colour) see page 228. | **Not included in the scope of delivery.

Spindle drive PLS

Fixings – specific applications – secondary closing edge
Heraol 085D

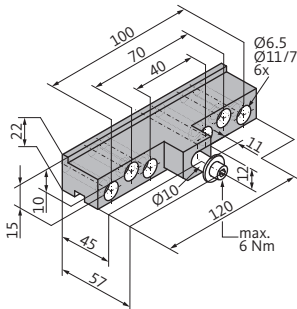

Chain holding fixture F28

Application

- Surface-mounted installation on secondary closing edge of sashes of outward-opening roof windows
- For spindle drives with front mounting
- Drill hole \varnothing 10 mm

Finish*	PU	Order number	
Aluminium (EV1), stainless steel	1 pc	155155	
Contents: 1 x chain holding fixture, 1 x pin \varnothing 10 mm, 1 x M5 screw, 1 x A5.3 washer			

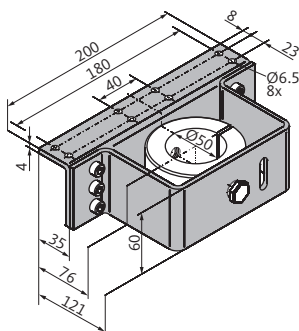

K121 mounting bracket

Application

- Surface-mounted installation on secondary closing edge of frames of outward-opening roof windows
- For swivel-mounting of spindle drives PLS
- In combination with clamping ring B6**

Finish*	PU	Order number	
Stainless steel	1 pc	155110	
Contents: 1 x mounting bracket			

Spindle drive SP

Product characteristics



230V



Product characteristics

- For controlled natural ventilation
- Easy to install with lateral dovetail groove
- Phosphated steel spindle with end position damping
- Anodised aluminium spindle tube
- Rugged corrosion-resistant design
- Aluminium housing anodised or in RAL colours as option with end cap and PVC base element
- Limit switch for protection against overloading

Spindle drive SP

Technical data



230V

Technical data

Specification	230 V AC
	SP8-Z S2 230V AC
Nominal voltage	230 V AC (50 Hz)
Nominal current	0.12 A
Breaking current	0.2 A
Nominal power	5 W
Duty ratio	5 cycles (ED 30% - ON: 3 min. / OFF: 7 min.)
Protection code	IP54
Ambient temperature	-5 °C to +60 °C
Max. pulling force	800 N
Max. locking force	3000 N [1]
Connecting cable	halogen-free, grey 6 x 0.75 mm ² , ~ 1 m
Speed	OPEN: 7.0 mm/s CLOSED: 7.0 mm/s
Max. travel	750 mm
Total length	see order information
Emission sound pressure level	≤ 70 dB (A)

[1] depends on fixing

Thrust with reference to travel

SP8-Z S2 230V AC

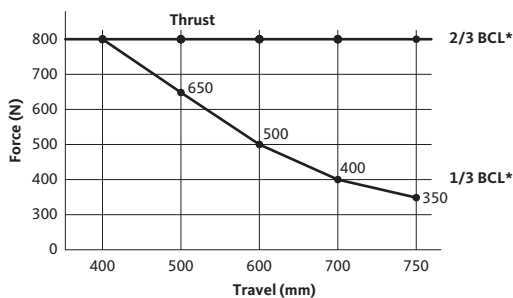

*BCL = Bracket clamping area

Spindle drive SP





Order information – version SP8Z S2 230V AC

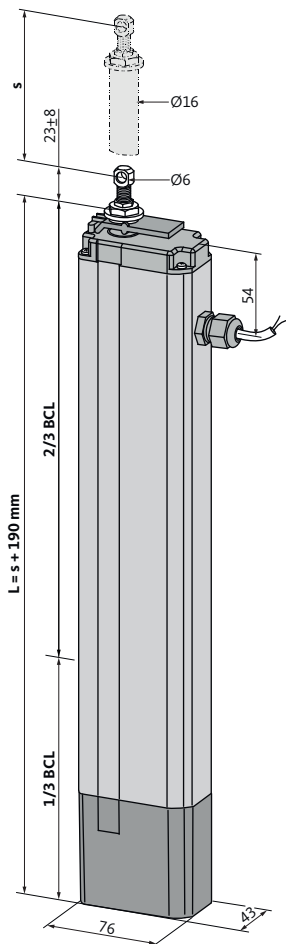

230V



Order information



Specification	SP8-Z S2 230V AC				
	Travel [s]	Length [L]	Finish*	PU	Order number
SP8-Z 300 S2 230V	300 mm	490 mm	EV1	1 pc	496231 
SP8-Z 400 S2 230V	400 mm	590 mm	EV1	1 pc	496241 
SP8-Z 500 S2 230V	500 mm	690 mm	EV1	1 pc	496251 
SP8-Z 600 S2 230V	600 mm	790 mm	EV1	1 pc	496261 
SP8-Z 750 S2 230V	750 mm	940 mm	EV1	1 pc	496276 

*Drive housing painted in special colour (RAL colour) see page 228.

Options

Mechanical travel reduction	Order number
Travel reduction without length – mechanical	516000 

Special cable lengths

Standard connecting cable length extended to:	Order number
3 m – halogen-free, grey – 6 x 0.75 mm ²	501163 
5 m – halogen-free, grey – 6 x 0.75 mm ²	501167 

Spindle drive SP

Fixings – overview and application examples



Overview of fixings

Example of application			3	6		
Mounting bracket			K59	K82		
Fixing accessories			B10 (included in the delivery scope of mounting bracket K59)	B13		
Chain holding fixture			F1 F10.6	F1 F10.6		
Space requirement	min. [mm]		35	45		
Sash material	Aluminium		■	■		
	Timber		■	■		
	PVC		■	■		
Sash and assembly type	Roof	outward	MCE	FI	-	■
				SI	■	-
	SCE	FI	-	-		
		SI	■	-		
ESW [1]	Solo	[mm]		450 – 1300		
ESH [1]	Solo	[mm]		450 – 1500		

Application examples

3	6
<p>Installation on frame, main closing edge, outward-opening roof window Shown on timber window</p>	<p>Installation on frame, main closing edge, outward-opening roof window Shown on aluminium window</p>

[1] The instructions of the particular profile system, hardware and glass manufacturers must be observed. The specifications for ESW/ESH apply accordingly for Side-Hung sashes.

Spindle drive SP

Fixings – chain holding fixtures – surface-mounted installation

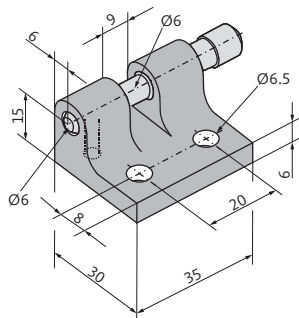

Chain holding fixture F1

Application

- Surface-mounted installation on main closing edge of outward-opening roof window sashes
- For spindle drives with front or rear mounting
- Drill hole \varnothing 6 mm
- The drive can be detached manually
- Max. load 1000 N

Finish*	PU	Order number	
Aluminium, die-cast	1 pc	150102	
Contents: 1 x chain holding fixture, 1 x locking pin \varnothing 6 mm			

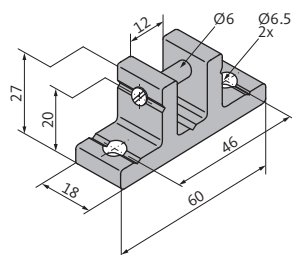

Chain holding fixture F10.6

Application

- Surface-mounted installation on main closing edge of outward-opening roof window sashes
- For spindle drives with front or rear mounting
- Drill hole \varnothing 6 mm
- Stud bolt, screwable
- Max. load 1600 N

Finish*	PU	Order number	
Aluminium	1 pc	151000	
Contents: 1 x chain holding fixture, 1 x stud bolt \varnothing 6 mm			

*Chain holding fixtures painted/powder-coated in special colour (RAL colour) see page 228.

Spindle drive SP

Fixings – mounting brackets – surface-mounted installation

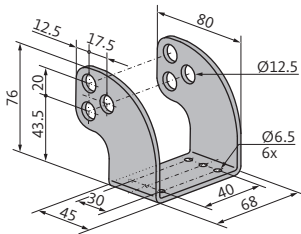

K82 mounting bracket

Application

- Surface-mounted installation on main closing edge of the frame of outward-opening roof windows
- For swivel-mounting of spindle drives SP
- In combination with clamping blocks B13**
- Drill holes \varnothing 12.5 mm

Finish*	PU	Order number	
Stainless steel	1 pc	151320	
Contents: 1 x mounting bracket			

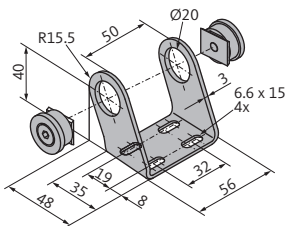

K59 mounting bracket

Application

- Surface-mounted installation on main closing edge of the frame of outward-opening roof windows
- For swivel-mounting of spindle drives SP
- In combination with mounting bracket K9**
- Distance between clamping axis and fixing plane 40 mm

Finish*	PU	Order number	
Steel, powder-coated (RAL 9006 silver)	1 pc	160934	
Contents: 1 x mounting bracket, 2 x B10 screw-type clamp connection			

*Mounting brackets painted/powder-coated in special colour (RAL colour) see page 228. | **Not included in the scope of delivery.

Spindle drive SP

Fixings – accessories

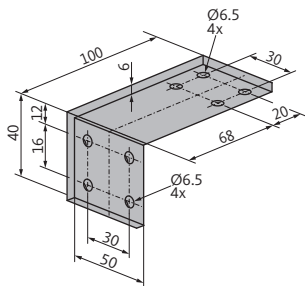

K9 mounting bracket

Application

- Relocation of fixing plane of mounting bracket K59 from horizontal to vertical orientation on the main closing edge of frame

Finish*	PU	Order number	
Aluminium (EV1)	1 pc	158501	
Contents: 1 x mounting bracket			

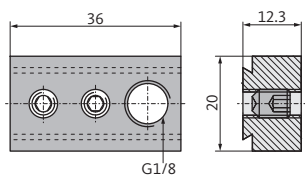

Clamping block B13

Application

- For swivel-mounting of SP8 drives to mounting bracket K82 with B8 flange bolt

Finish*	PU	Order number	
Aluminium	2 pc	513901	
Contents: 2 x clamping block, 2 x B8 flange bolt Ø 12 mm			







1.4 Door and window drives 24 V DC

Flap lever drive FTA600	180
Flap lever drive FTA600 R	184
Flap lever drive FTA600 DF	188
Flap lever drive FTA600 GF	190

Flap lever drive FTA600

System overview



With the FTA600 R flap lever drive you can also use swing doors in entrance areas as supply air for smoke and heat exhaust ventilation and also maintain the integrity of the escape route.

When combined with the SECURY 19 and GU-SECURY Automatic multi-point locking systems with A-opener* or the BKS motor-driven lock, this drive solution also satisfies further functions apart from the main function "Door", e.g. fulfilment of safety and fire protection requirements.

The FTA600 R flap lever drive is suitable for 1- and 2-leaf doors – also when used as emergency exit or escape door according to EN 179 / EN 1125.

Beside the supply air application on the door, the FTA600 in the versions FTA600 DF or FTA600 GS can also be used on automated Side-Hung windows in the facade for smoke exhaust (SHEV exhaust air) or for natural ventilation. The Side-Hung window drives are surface-mounted on frame or sash frame of the secondary closing edges.

Flap lever drive FTA600

System overview



SHEV supply air with FTA600 R flap lever drive

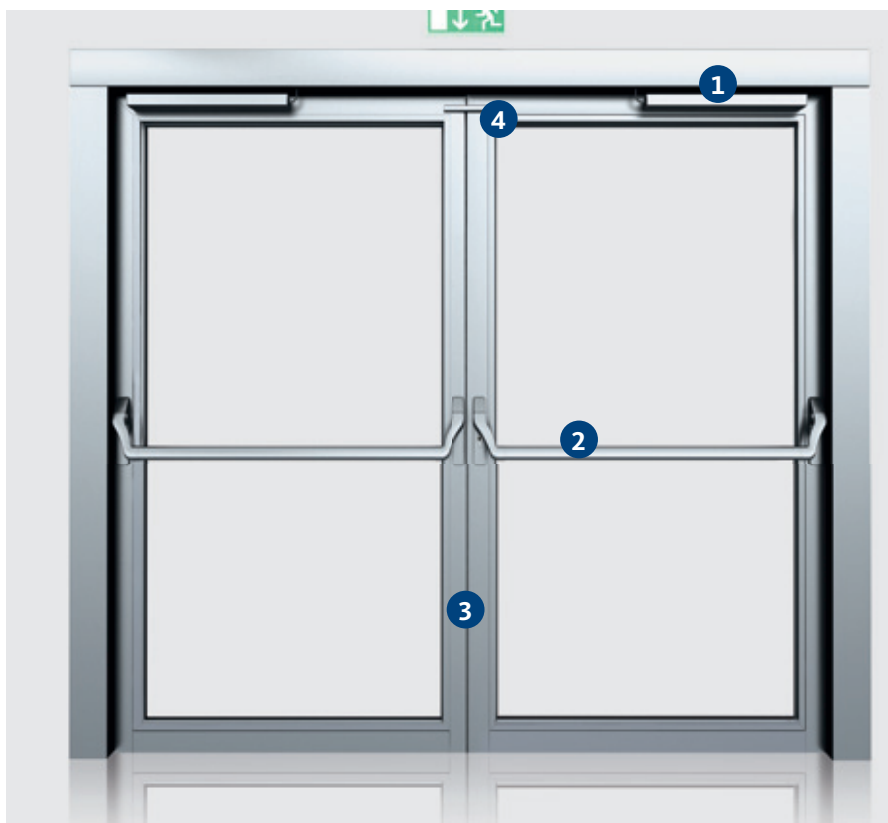

Adequately sized supply air openings are always required to ensure that the smoke and heat extraction system functions safely and reliably. By means of a kind of "chimney effect", these boost the thermal uplift and thus ensure that smoke gases are drawn upwards and extracted more quickly.

The supply air opening must be 1.5 times larger than the area of all exhaust air openings in the space concerned. The supply air opening must also be fully located in the low-smoke layer.

Components

- 1 Flap lever drive FTA600
- 2 Push bar
- 3 SECURITY 19 / GU-SECURITY Automatic with A-opener* / motor-driven lock / motor-driven shoot-bolt lock
- 4 Carrier bar

Functions

- **Smoke exhaust:** fast and reliable smoke exhaust via the extraction apertures by the automatic supply air opening in the door in case of fire
- **Comfortable access:** the FTA600 flap lever drive is inactive during everyday operation, so the doors can be accessed without having to overcome an opposing force
- **Burglar protection:** high level of security due to SECURITY 19 automatic multi-point locking, GU-SECURITY Automatic with A-opener*, motor-driven shoot-bolt lock or motor-driven lock series 19
- **Panic function:** escaping from inside is possible at any time (emergency exit doors EN 179 / panic doors EN 1125)

*The multi-point lock GU-SECURITY Automatic is not suitable for use in emergency exit doors or escape doors in accordance with EN 179 / EN 1125.

Flap lever drive FTA600

Product characteristics



24V



Product characteristics

- For controlled natural ventilation, SHEV and NSHEV according to EN 12101-2
- **Version R**
 - With roller
 - Flap lever opens via the roller to 90° to admit incoming fresh air
- **Version DF**
 - With guide lever for opening and closing inward-opening Side-Hung windows to 90°
- **Version GF**
 - With slide rail for opening and closing outward-opening Side-Hung windows to 90°
- Opening time of approx. 45 s for approx. 90° opening angle
- Programmable "End position" or "Open" potential-free contact
- Rugged corrosion-resistant design
- Easy to install fixing via drill holes in housing end pieces
- Programmable parameters of the intelligent S12 control electronics*
 - Synchronised multiple operation and sequential control of max. 4 drives
 - Soft start and soft stop at the end positions
 - Opening angle, closing force, speed
 - Reversing in the event of overload cut-off during the closing operation
- Integrated plug solution
- Suitable for operation with M-COM for automatic configuration of synchronous running and sequential controls
- Aluminium body anodised or in RAL colours as option
- Flap lever made of aluminium (RAL 9006)

*For programming of S12 control electronics see page 229.

Flap lever drive FTA600

Technical data



24V

Technical data

Specification	24 V DC		
	FTA600 R S12 24V DC	FTA600 DF S12 24V DC	FTA600 GF S12 24V DC
Nominal voltage	24 V DC (19 V ... 28 V)	24 V DC (19 V ... 28 V)	24 V DC (19 V ... 28 V)
Nominal current	1.0 A	1.0 A	1.0 A
Breaking current	1.4 A	1.4 A	1.4 A
Nominal power	24 W	24 W	24 W
Duty ratio	5 cycles (ED 30% - ON: 3 min. / OFF: 7 min.)		
Protection code	IP32		
Ambient temperature	-5 °C to +60 °C		
Force (torque) max.	OPEN	600 N (~ 215 Nm)	600 N (~ 215 Nm)
	CLOSE	600 N (~ 215 Nm)	600 N (~ 215 Nm)
Max. locking force	No connection to moving parts (roller)	3000 N [1]	3000 N [1]
Connecting cable	halogen-free, grey 5 x 0.5 mm ² , ~ 3 m	halogen-free, grey 5 x 0.5 mm ² , ~ 3 m	halogen-free, grey 5 x 0.5 mm ² , ~ 3 m
Runtime (0° – 90°) (with ½ load, constant)	OPEN: 45 s (2.0 °/s) CLOSE: 45 s (2.0 °/s)	OPEN: 45 s (2.0 °/s) CLOSE: 45 s (2.0 °/s)	OPEN: 45 s (2.0 °/s) CLOSE: 45 s (2.0 °/s)
Opening angle (lever)	0 – 93 DEG (± 5 %)	0 – 93 DEG (± 5 %)	0 – 93 DEG (± 5 %)
Total length	421 mm	421 mm	421 mm
Potential-free contact	max. 24 V DC / 0.5 A programmable		
Emission sound pressure level	≤ 70 dB (A)		

[1] depends on fixing

Flap lever drive FTA600

Order information



24V

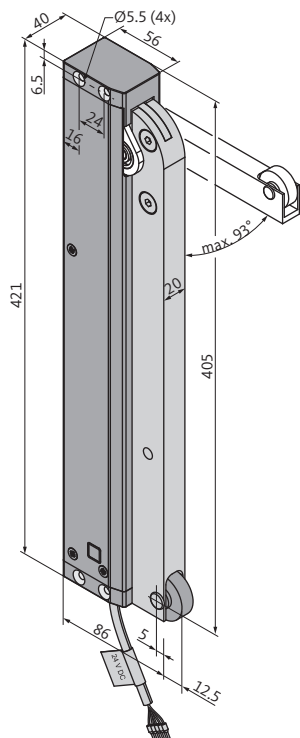



Order information

Specification	FTA600 R S12 24V DC		
	Finish*	PU	Order number
FTA600 R S12 24V	EV1	1 pc	524144 

*Drive housing painted in special colour (RAL colour) see page 228.

Plug solution

Wire Click	PU	Order number
3 m – halogen-free, grey – 5 x 0.5 mm ²	1 pc	501251 
5 m – halogen-free, grey – 5 x 0.5 mm ²	1 pc	501252 
10 m – halogen-free, grey – 5 x 0.5 mm ²	1 pc	501253 

Optional accessories

Specification	PU	Order number
M-COM configuration module for interconnected drive systems	1 pc	524177 

Flap lever drive FTA600 R

Fixings – set of mounting brackets – surface-mounted installation

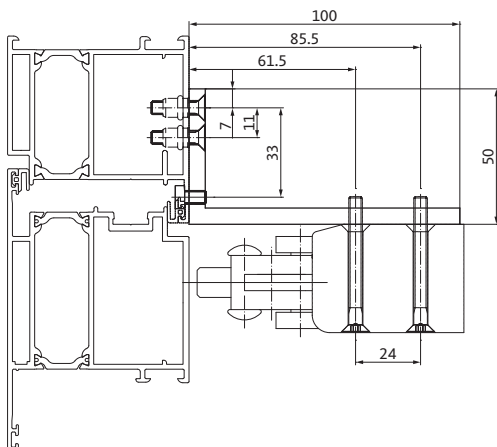
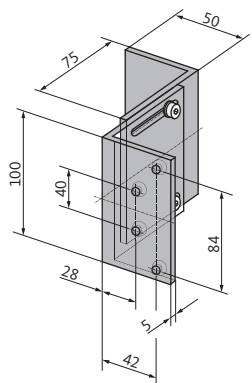
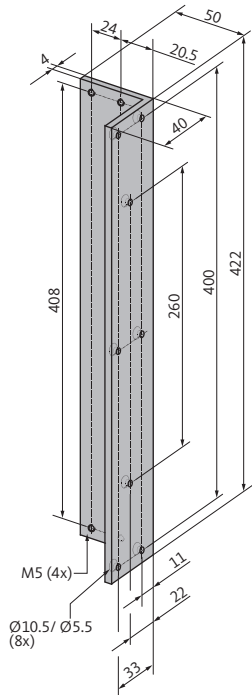

Set of mounting brackets K88

Application

- Surface-mounted installation on frame of secondary closing edge of inward-opening incoming fresh air openings
- 1 x 422 mm angle bracket for mounting of FTA600 R flap lever drive
- 2 x 100 mm angle bracket for mounting as slideway for carrier bar roller, with adjustment option to compensate for sash overlap
- Max. load 600 N

Finish*	PU	Order number
Aluminium (EV1)	1 pc	524156 
Contents: 1 x 50x40x422 mm angle bracket, 2 x 50x75x100 mm angle bracket, fixing screws, nuts		

Mounting bracket [1]

Application

- Surface-mounted installation on frame of secondary closing edge of outward-opening incoming fresh air openings
- Max. load 600 N

Finish	PU	Order number
EV1, silver	1 St.	9-45614-00-0-1 

*Mounting brackets painted/powder-coated in special colour (RAL colour) see page 228. | [1] without fixing screws; 2 brackets are required per drive

Flap lever drive FTA600 R

Mounting examples

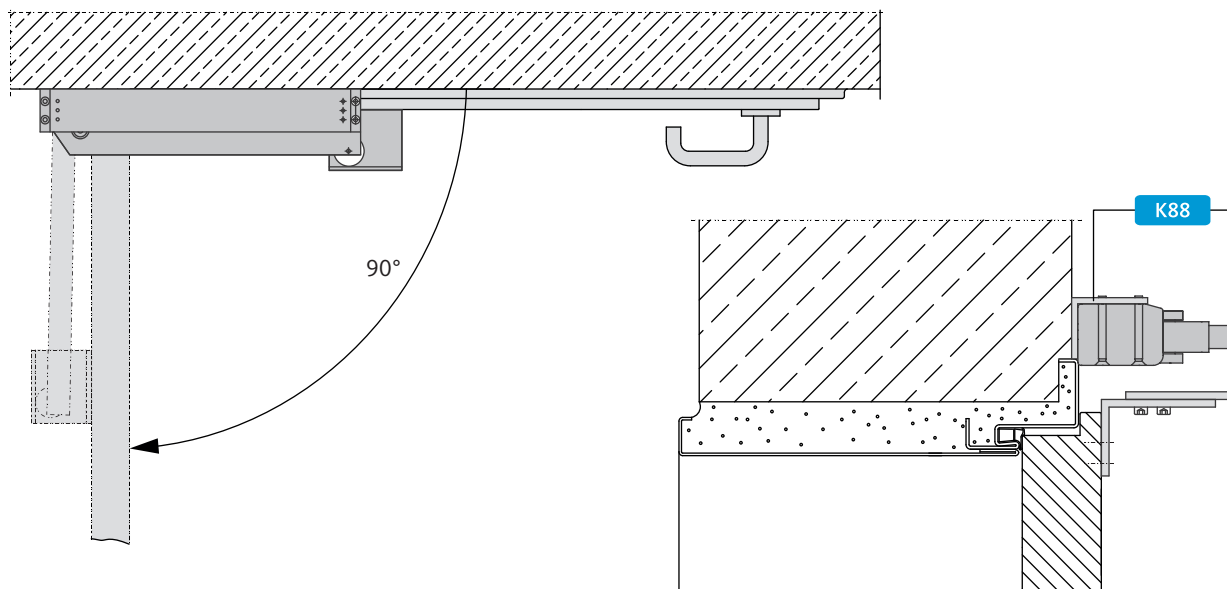
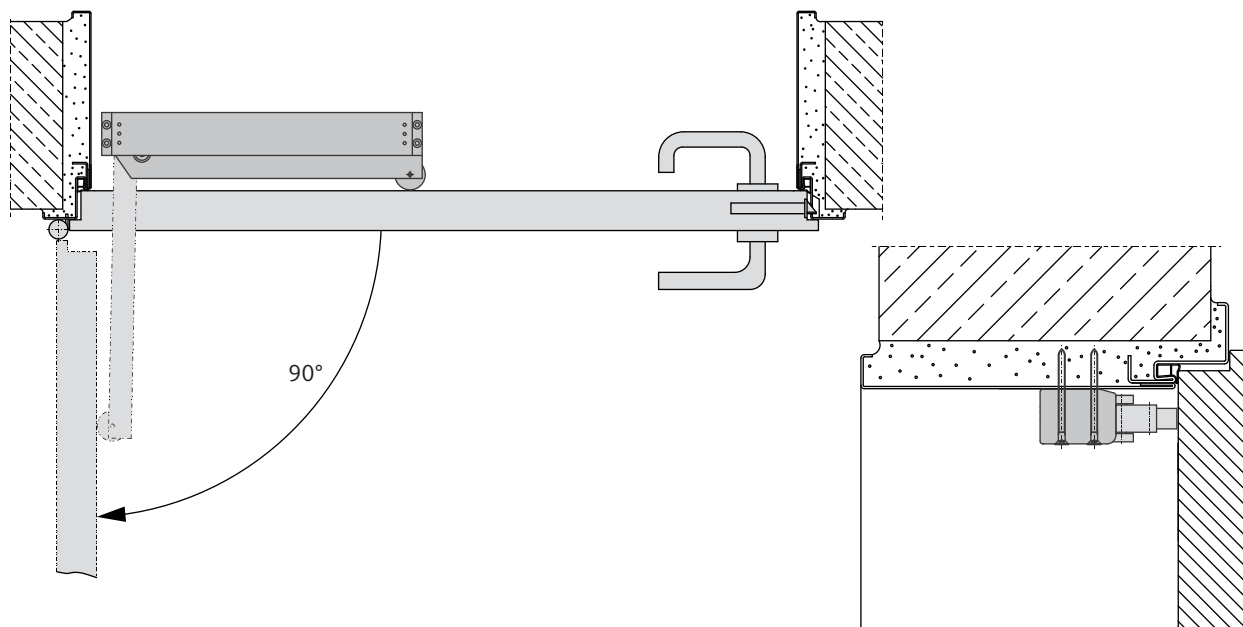



Flap lever drive FTA600 DF

Order information



24V

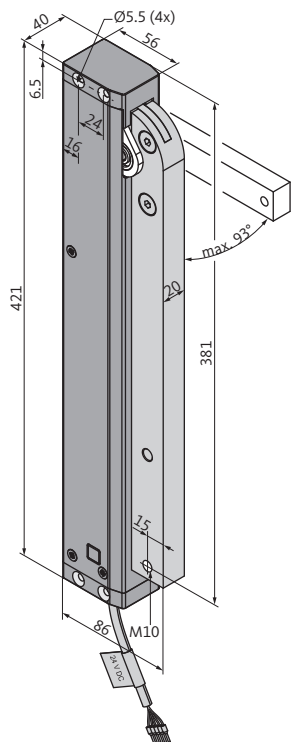



Order information

Specification	FTA600 DF S12 24V DC		
	Finish*	PU	Order number
FTA600 DF S12 24V	EV1	1 pc	524145 

*Drive housing painted in special colour (RAL colour) see page 228.

Plug solution

Wire Click	PU	Order number
3 m – halogen-free, grey – 5 x 0.5 mm ²	1 pc	501251 
5 m – halogen-free, grey – 5 x 0.5 mm ²	1 pc	501252 
10 m – halogen-free, grey – 5 x 0.5 mm ²	1 pc	501253 

Optional accessories

Specification	PU	Order number
M-COM configuration module for interconnected drive systems	1 pc	524177 

Flap lever drive FTA600 DF

Fixings – set of mounting brackets – surface-mounted installation

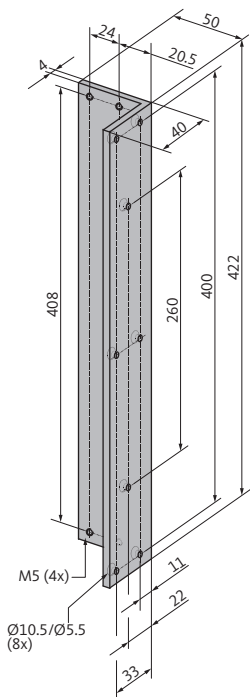

Set of mounting brackets K103

Application

- Surface-mounted installation on secondary closing edge frame of outward-opening Side-Hung sashes
- 1 x 422 mm angle bracket for mounting of FTA600 DF flap lever drive on frame
- 1 x F1 chain holding fixture for fixing to sash and mounting guide lever, with adjustment option to compensate for sash overlap
- Max. load 600 N

Finish*	PU	Order number	
Aluminium (EV1)	1 pc	524172	
Contents: 1 x 50x40x422 mm angle bracket, 1 x F1 chain holding fixture, connection accessories			

Mounting example

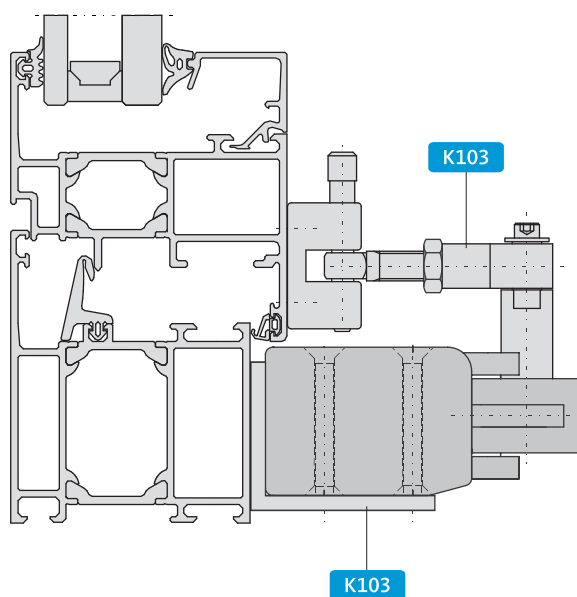
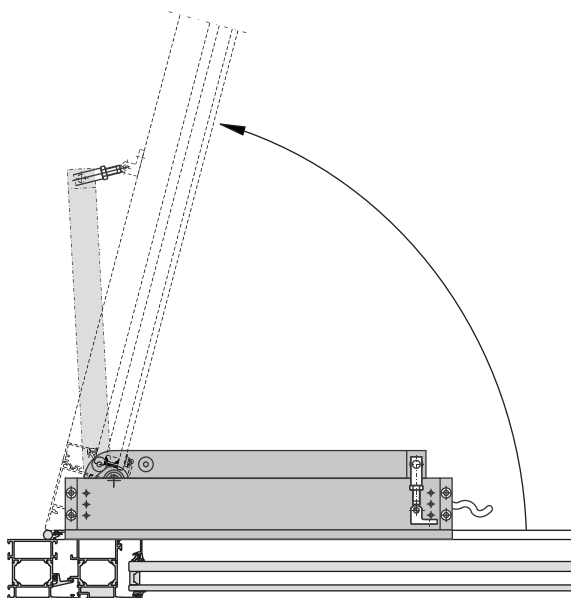

*Mounting brackets painted/powder-coated in special colour (RAL colour) see page 228.

Flap lever drive FTA600 GF

Order information



24V

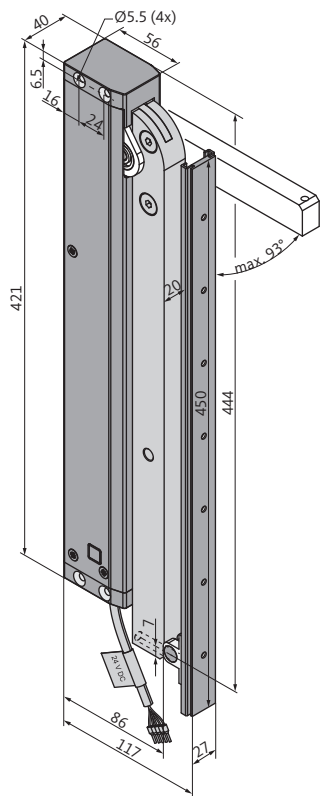



Order information

Specification	FTA600 GF S12 24V DC		
	Finish*	PU	Order number
FTA600 GF S12 24V	EV1	1 pc	524146 

*Drive housing painted in special colour (RAL colour) see page 228.

Plug solution

Wire Click	PU	Order number
3 m – halogen-free, grey – 5 x 0.5 mm ²	1 pc	501251 
5 m – halogen-free, grey – 5 x 0.5 mm ²	1 pc	501252 
10 m – halogen-free, grey – 5 x 0.5 mm ²	1 pc	501253 

Optional accessories

Specification	PU	Order number
M-COM configuration module for interconnected drive systems	1 pc	524177 

Flap lever drive FTA600 GF

Fixings – set of mounting brackets – surface-mounted installation

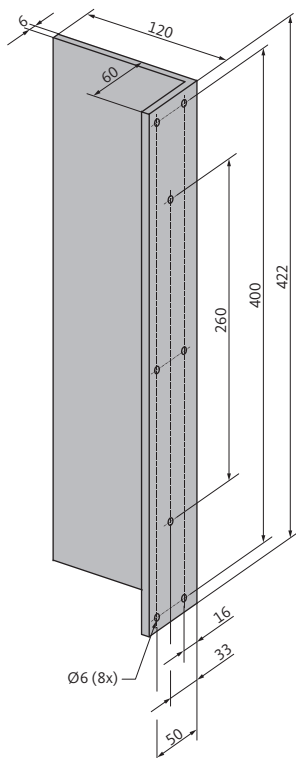

Set of mounting brackets K104

Application

- Surface-mounted installation on secondary closing edge frame of outward-opening Side-Hung sashes
- 1 x 422 mm angle bracket for mounting of FTA600 GF flap lever drive on frame
- The slide rail of the drive is mounted on the sash
- Max. load 600 N

Finish*	PU	Order number	
Aluminium (RAL 9006)	1 pc	524173	
Contents: 1 x 120x60x422 mm angle bracket, 4 x M5x45 countersunk screw			

Mounting example

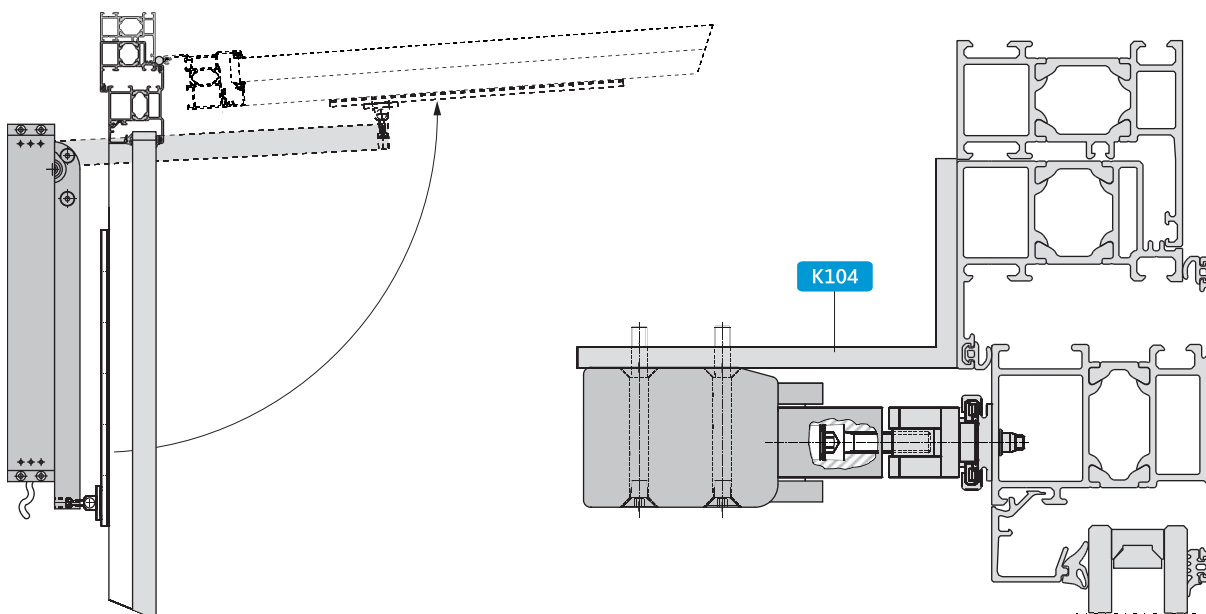

*Mounting brackets painted/powder-coated in special colour (RAL colour) see page 228.





1.5 SHEV hardware systems 24 V DC

SHEV hardware systems	194
RWA 1000 hardware system	198
RWA 1100 hardware system	206
RWA 1050 hardware system	212

SHEV hardware systems

System overview



With their combined drive and locking unit, SHEV hardware systems from the Gretsch-Unitas group are the ideal solution wherever there is little space on the frame side.

They automatically open and close vertically installed, inward and outward opening Bottom-Hung, Top-Hung and Side-Hung windows everywhere where large opening widths are to be achieved with minimum lift.

The spindle drives are closely positioned on the window profile instead of projecting into the room.

The combined locking via the additional locking points increases both the tightness of the window element and the burglar protection.

The systems can also be used in synchronous mode for large and heavy window elements.

Each system consists of a drive, mounting bracket set and electromechanical sash locking.

SHEV hardware systems

System overview



SHEV 1000

- Application: inward-opening Bottom-Hung/Top-Hung/Side-Hung sash
- Opener drives: PL6 S1 (600 N) / PL10 S1 (1000 N) on secondary closing edge
- Locking drives: FV3 / OFV / (FV1 with USKM) on main closing edge
- Mounting brackets: K15 / B20
- Chain holding fixtures: F11
- Variants: Solo / Tandem (with USKM)



SHEV 1100

- Application: outward-opening Bottom-Hung/Top-Hung/Side-Hung sash
- Opener drives: PL6 S1 (600 N) / PL10 S1 (1000 N) on secondary closing edge
- Locking drives: FV3 / (FV1 with USKM) on main closing edge
- Mounting brackets: K15 / K37 / B20
- Chain holding fixtures: F11
- Variants: Solo / Tandem (with USKM)



SHEV 1050

- Application: inward-opening Side-Hung sash
- Opener drives: PL6 S1 (600 N) / PL10 S1 (1000 N) on secondary closing edge
- Locking drives: FV3 / OFV / (FV1 with USKM) on main closing edge
- Mounting brackets: K97 right / left
- Chain holding fixtures: F11
- Variants: Solo / Tandem (with USKM)

SHEV hardware systems

System overview



SHEV hardware systems

Specification	Nominal voltage	Locking drive			Opener drives	Accessories		
		Product	Quantity LP	Lengths [mm]		Control module Accessories	Mounting bracket	Chain holding fixture
SHEV 1000	24 V DC	FV3	1 [1]	450	PL6 PL10	(B20-1)	K15	F11
		OFV	[2]	-	PL6 PL10	-	K15	F11
SHEV 1000-TE	24 V DC	FV1	2; 3	1200	2 x PL6 2 x PL10	USKM	2 x K15	2 x F11
			3	2000	2 x PL6 2 x PL10	USKM	2 x K15	2 x F11
		OFV	[2]	-	2 x PL6 2 x PL10	USKM	2 x K15	2 x F11
SHEV 1100	24 V DC	FV3 [2]	1 [1]	450	PL6 PL10	B21-1	K15 (K37)	F11
SHEV 1100-TE	24 V DC	FV1 [2]	2; 3	1200	2 x PL6 2 x PL10	USKM (B20-2)	2 x K15 (2 x K37)	2 x F11
			3	2000	2 x PL6 2 x PL10	USKM (B20-3)	2 x K15 (2 x K37)	2 x F11
SHEV 1050	24 V DC	FV3 [2]	-	-	PL6 PL10	-	K97 (right / left)	F11
		OFV	[2]	-	PL6 PL10	-	K97 (right / left)	F11
SHEV 1050-TE	24 V DC	FV1	[1]	-	2 x PL6 2 x PL10	USKM	K97 (right + left)	2 x F11
		OFV	[2]	-	2 x PL6 2 x PL10	USKM	K97 (right + left)	2 x F11

■ suitable | ● less suitable

[1] On MCE of Side-Hung sashes, FV can be used with 2 or 3 locking points
 [2] System-specific multi-point locking system

SHEV hardware systems

System overview



Sash data							Space require- ment on frame	Application			Application		
Bottom-Hung/Top-Hung			Side-Hung			Ventila- tion		SHEV	NSHEV	Facade		Roof	
ESW	ESH	SW max.	ESW	ESH	SW max.					inward	outward		
[mm]	[mm]	[kg]	[mm]	[mm]	[kg]	[mm]							
500–1200	600–1500	50	600–1500	500–2400	90	40	■	■	■	■	●	●	
		90			150		■	■	■	■	●	●	
500–1200	600–1500	50	500–1500	500–2400	90	40	■	■	■	■	●	●	
		90			150		■	■	■	■	●	●	
1250–2400	600–2000	90	600–1500	1250–2400	130	40	■	■	■	■	●	●	
		160			200		■	■	■	■	●	●	
2050–2400	600–2000	90	600–1500	2050–2400	130	40	■	■	■	■	●	●	
		160			200		■	■	■	■	●	●	
500–1200	600–1500	50	500–1500	500–2400	90	40	■	■	■	■	●	●	
		90			150		■	■	■	■	●	●	
500–1200	800–1600	70	600–1500	500–2400	90	40	■	■	■	●	■	●	
		120			150		■	■	■	●	■	●	
1250–2400	800–2000	130	600–1500	1250–2400	130	40	■	■	■	●	■	●	
		200			200		■	■	■	●	■	●	
2050–2400	800–2000	130	600–1500	2050–2400	130	40	■	■	■	●	■	●	
		200			200		■	■	■	●	■	●	
–	–	–	550–1250	500–1500	90	22	■	■	■	■	●	●	
					130		■	■	■	■	●	●	
–	–	–	550–1250	500–1500	90	22	■	■	■	■	●	●	
					130		■	■	■	■	●	●	
–	–	–	550–1500	500–2400	130	22	■	■	■	■	●	●	
					150		■	■	■	■	●	●	
–	–	–	550–1500	500–2400	130	22	■	■	■	■	●	●	
					150		■	■	■	■	●	●	

RWA 1000 hardware system

Product characteristics



24V



Product characteristics

- For controlled natural ventilation, SHEV and NSHEV according to EN 12101-2
- Application on inward-opening Bottom-Hung sashes, Top-Hung sashes and Side-Hung sashes
- Large opening angles with short travels and opening times due to the installation of the spindle drives at an acute angle ($> 12^\circ$) to the secondary closing edge (SCE)
- Maximum opening angle with balanced ratio between force, travel and angle of attack when installing the mounting bracket K15 at:
 - approx. 1/3 of the secondary closing edge length of the sash with reference to the hinge
- Spindle drives can be combined in Solo/Tandem arrangement with different locking drives for actuation of profile-specific hardware systems on request

RWA 1000 hardware system

Mounting examples



Mounting examples: RWA 1000

Solo arrangement

RWA 1000 Solo inward-opening
Shown on Bottom-Hung sash

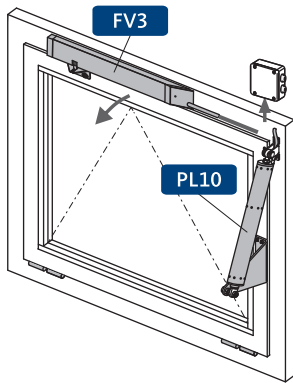

RWA 1000 Solo inward-opening
Shown on Bottom-Hung sash

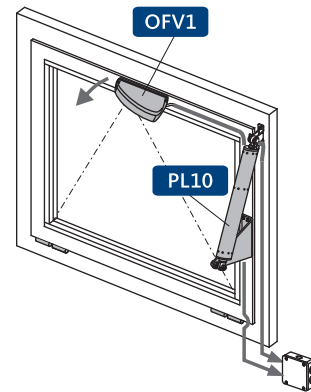

RWA 1000 Solo inward-opening
Shown on Top-Hung sash

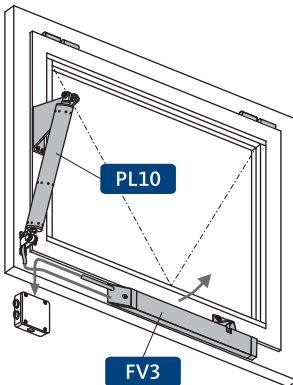

RWA 1000 Solo inward-opening
Shown on Side-Hung sash

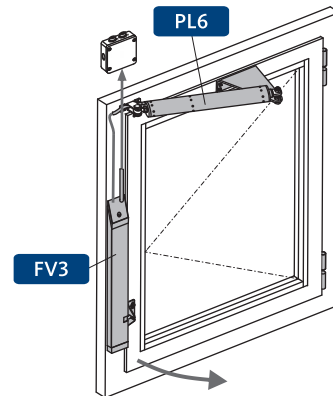

Tandem arrangement

RWA 1000 Tandem inward-opening
Shown on Bottom-Hung sash

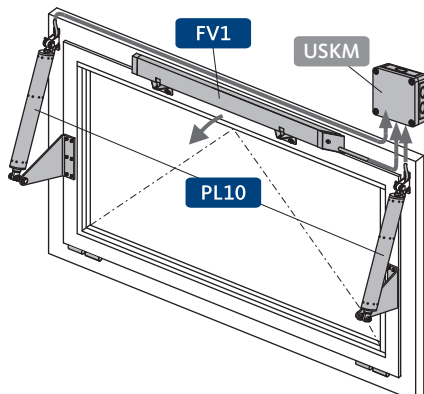

RWA 1000 hardware system

Installation dimensions



Installation dimensions of RWA 1000 on inward-opening Bottom-Hung and Top-Hung sashes

Door hardware	Mounting bracket	Travel Opening drive	Closed		Installation dimension "X" [1][2]	Sash external height	Opening angle	Opening width	
			Angle of attack Drive	Force application at point of attack					
				PL6					PL10
		[mm]	[DEG]	[N]	[N]	[mm]	[mm]	[DEG]	[mm]
SHEV 1000 [3]	K15	100	19	195	326	200	560	25	242
						250	610	22	233
						300	660	20	229
						400	760	17	225
						500	860	15	225
						600	960	13	217
		150	16	165	276	225	645	34	377
						275	695	30	360
						325	745	28	360
						450	870	23	347
						550	970	20	337
						650	1070	18	335
		200	15	155	259	250	720	42	516
						300	770	38	501
						350	820	35	493
						400	870	32	480
						500	970	27	453
						600	1070	24	445
						700	1170	22	446
						800	1270	20	441
		250	13	135	225	275	795	50	672
						325	845	45	647
						375	895	41	627
						425	945	38	615
						550	1070	31	572
						650	1170	28	566
						750	1270	25	550
						850	1370	23	546
		300	12	125	208	300	870	56	817
						350	920	51	792
						400	970	46	758
						450	1020	43	748
						500	1070	40	732
						600	1170	35	704
						700	1270	31	679
						800	1370	28	663
900	1470					26	661		
1000	1570					24	653		

[1] Installation dimension X = distance from mounting bracket K15 to hinge side ($\geq \frac{1}{2}$ ESH)

[2] Other installation dimensions and sash heights available on request.

[3] For RWA 1000-TE the drive forces and sash weights must be doubled.

[4] FV1 - 1-fold = 450 mm

FV1 - 2-fold = 1200 or 2000 mm

FV1 - 3-fold = 2000 mm

RWA 1000 hardware system

Installation dimensions



	Open		Max. sash weight		Space requirement on frame		Sash external width	
	Angle of attack Drive	Force application at point of attack						
		[DEG]	PL6 [N]	PL10 [N]	PL6 [kg]	PL10 [kg]	SCE [mm]	MCE [mm]
	48	447	745	32	53	40	40	depending on locking drive [4]
	47	442	736	36	60			
	47	437	729	40	66			
	46	430	717	45	75			
	47	442	736	51	86			
	45	422	703	53	88			
	57	503	838	35	58	40	40	
	55	490	817	39	65			
	54	487	811	42	71			
	52	474	790	49	82			
	51	467	778	53	88			
	50	462	769	56	93			
	64	541	902	38	63	40	40	
	62	531	885	41	69			
	61	523	872	45	74			
	59	516	861	47	79			
	57	503	839	52	86			
	56	497	829	56	93			
	55	491	818	59	98			
	54	486	810	61	102			
	71	567	945	39	65	40	40	
	68	557	928	43	71			
	66	549	915	46	77			
	65	544	906	49	81			
	62	528	880	54	90			
	60	519	865	58	96			
	59	513	854	61	101			
	58	507	844	63	105			
	77	584	973	40	67	40	40	
	74	576	959	44	73			
	71	569	948	47	78			
	69	561	935	50	83			
	68	555	925	52	86			
	65	544	907	56	93			
	63	536	893	59	98			
	62	529	882	62	103			
	61	523	872	64	107			
	60	519	864	66	110			

RWA 1000 hardware system

Order information – version PL10 S1 + FV3-R (1-fold)

24V

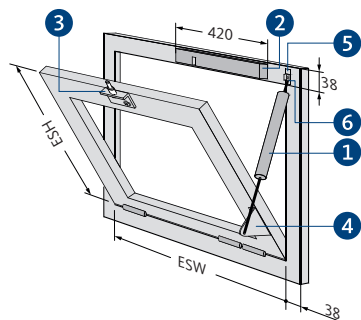

1 x PL10 S1
(100 / 150 / 200 / 300 mm)



1 x FV3-R or 1 x FV3-L (1-fold) L = 420 mm



B18 (incl.)



1 x K15 set:

1 x K15

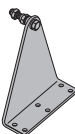

1 x F11



1 x B16ST (8x40)



Order information

Components		PU	Order number	
1 x spindle drive PL10 S1				
PL10-100	ESH min. 550 mm	1 pc	565010	
PL10-150	ESH min. 600 mm	1 pc	565015	
PL10-200	ESH min. 700 mm	1 pc	565020	
PL10-300	ESH min. 1000 mm	1 pc	565030	
1 x locking drive FV3 (Version R or L)				
FV3-R (1-fold)	Length = 420 mm ESW min. 450 mm	1 pc	515102	
FV3-L (1-fold)		1 pc	515105	
1 x mounting bracket set				
K15 set		1 pc	517590	
Optional accessories				
B21-1 packer FV	Length = 420 mm Sash overlap = > 10 mm	1 pc	515181	
B22 packer for B18		1 pc	301599	

Installation prerequisites

Opening direction	inward
Fixing dimension of drive (eye – eye)	280 ± 7 mm + travel
Space requirement of locking drive (FV)	min. 38 mm
Space requirement of spindle drive (PL)	min. 38 mm
Leaf weight	max. 30 kg/m ²
Sash external width	450–1300 mm
External sash height min.	see installation dimensions
Nominal voltage	24 V DC (19V ... 28V)
Breaking current	0.8 A
Rated output	15 W

RWA 1000 hardware system

Order information – version PL10 S1 + OFV1



24V

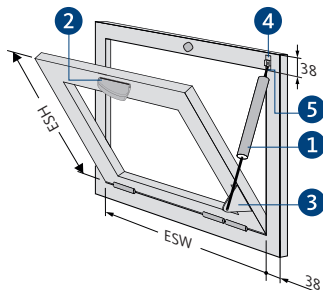

- 1 1 x PL10 S1
(100 / 150 / 200 / 300 mm)



- 2 1 x OFV1



- 1 x K15 set

- 3 1 x K15

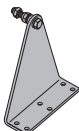

- 4 1 x F11



- 5 1 x B16ST (8x40)



Order information

Components		PU	Order number	
1 x spindle drive PL10 S1				
PL10-100	ESH min. 550 mm	1 pc	565010	
PL10-150	ESH min. 600 mm	1 pc	565015	
PL10-200	ESH min. 700 mm	1 pc	565020	
PL10-300	ESH min. 1000 mm	1 pc	565030	
1 x locking drive OFV				
OFV1	ESW min. 450 mm	1 pc	513850	
Mounting bracket set				
K15 set		1 pc	517590	

Installation prerequisites	
Opening direction	inward
Fixing dimension of drive (eye – eye)	280 ± 7 mm + travel
Space requirement of locking drive (OFV) on sash frame	min. 40 mm
Space requirement of spindle drive (PL) on window frame	min. 38 mm
Leaf weight	max. 30 kg/m ²
Sash external width	450–1300 mm
External sash height min.	see installation dimensions
Nominal voltage	24 V DC (19V ... 28V)
Breaking current	1.1 A
Rated output	26 W

RWA 1000-TE hardware system

Order information – version PL10 S1 + FV1-R (2-fold) + USKM

24V

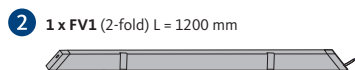
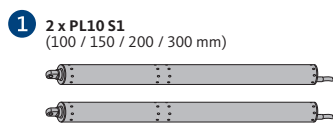
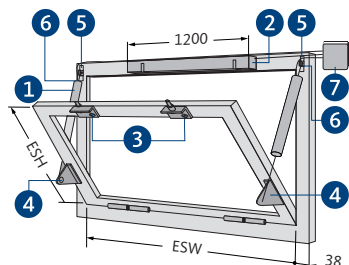

2 x K15 set

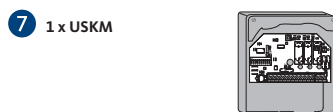

Order information

Components		PU	Order number	
2 x spindle drive PL10 S1				
PL10-100	ESH min. 550 mm	1 pc	565010	
PL10-150	ESH min. 600 mm	1 pc	565015	
PL10-200	ESH min. 700 mm	1 pc	565020	
PL10-300	ESH min. 1000 mm	1 pc	565030	
1 x locking drive FV1				
FV1-R (2-fold)	Length = 1200 mm ESW min. 1200 mm	1 pc	515111	
2 x mounting bracket set				
K15 set		1 pc	517590	
1 x inspection module				
USKM		1 pc	512140	
Optional accessories				
B21-2 packer FV	Length = 1200 mm Sash overlap = > 10 mm	1 pc	515183	
B22 packer for B18		1 pc	301599	

Installation prerequisites	
Opening direction	inward
Fixing dimension of drive (eye – eye)	280 ± 7 mm + travel
Space requirement of locking drive (FV)	min. 38 mm
Space requirement of spindle drive (PL)	min. 38 mm
Leaf weight	max. 30 kg/m ²
Sash external width	1200–2500 mm
External sash height min.	see installation dimensions
Nominal voltage	24 V DC (19V ... 28V)
Breaking current	1.6 A
Rated output	30 W

RWA 1000-TE hardware system

Order information – version PL10 S1 + OFV1 + USKM

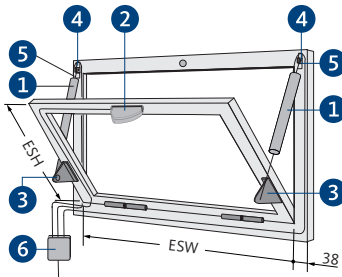

- 1 2 x PL10 S1
(100 / 150 / 200 / 300 mm)



- 2 1 x OFV1



2 x K15 set

- 3 2 x K15

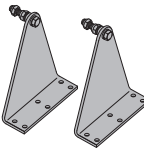

- 4 2 x F11

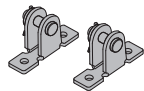

- 5 2 x B16ST (8x40)

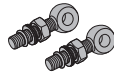

- 6 1 x USKM

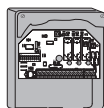

Order information

Components		PU	Order number	
2 x spindle drive PL10 S1				
PL10-100	ESH min. 550 mm	1 pc	565010	
PL10-150	ESH min. 600 mm	1 pc	565015	
PL10-200	ESH min. 700 mm	1 pc	565020	
PL10-300	ESH min. 1000 mm	1 pc	565030	
1 x locking drive OFV				
OFV1	ESW min. 450 mm	1 pc	513850	
2 x mounting bracket set				
K15 set		1 pc	517590	
1 x inspection module				
USKM		1 pc	512140	

Installation prerequisites

Opening direction	inward
Fixing dimension of drive (eye – eye)	280 ± 7 mm + travel
Space requirement of locking drive (OFV) on sash frame	min. 40 mm
Space requirement of spindle drive (PL) on window frame	min. 38 mm
Leaf weight	max. 30 kg/m ²
Sash external width	450–1300 mm
External sash height min.	see installation dimensions
Nominal voltage	24 V DC (19V ... 28V)
Breaking current	1.6 A
Rated output	30 W

RWA 1100 hardware system

Product characteristics



24V

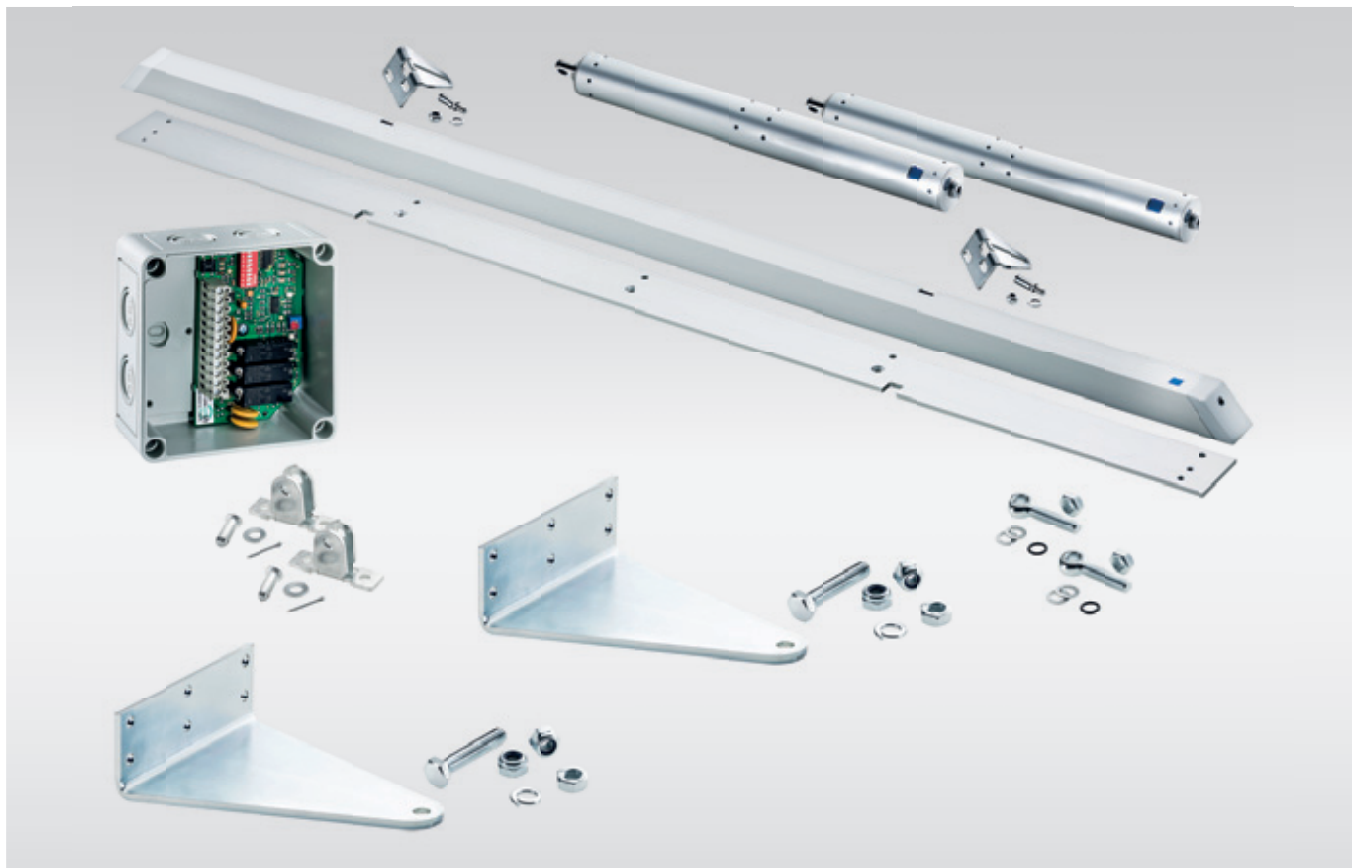

Product characteristics

- For controlled natural ventilation, SHEV and NSHEV according to EN 12101-2
- Application on outward-opening Bottom-Hung sashes, Top-Hung sashes and Side-Hung sashes
- Large opening angles with short travels and opening times due to the installation of the spindle drives at an acute angle ($> 12^\circ$) to the secondary closing edge (SCE)
- Maximum opening angle with balanced ratio between force, travel and angle of attack when installing the rebate corner-hinge F11 at:
 - approx. 1/2 of the secondary closing edge of the sash when using the mounting bracket K15
 - approx. 1/3 of the secondary closing edge of the sash with reference to the hinge when using the mounting bracket K37
- Spindle drives can be combined in Solo or Tandem arrangement with different locking drives for actuation of profile-specific hardware systems on request
- Can be used on roof windows with other drive/mounting bracket combinations and mounting positions on request

RWA 1100 hardware system

Mounting examples



Mounting examples: RWA 1100

Solo arrangement

RWA 1100 Solo outward-opening
Shown on Bottom-Hung sash

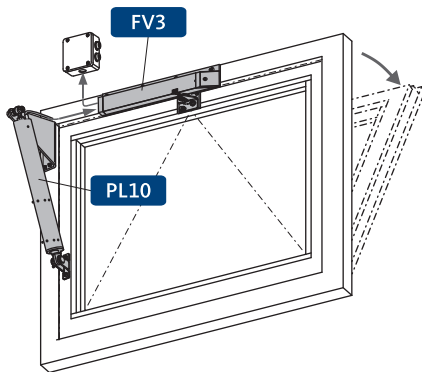

RWA 1100 Solo outward-opening
Shown on Top-Hung sash

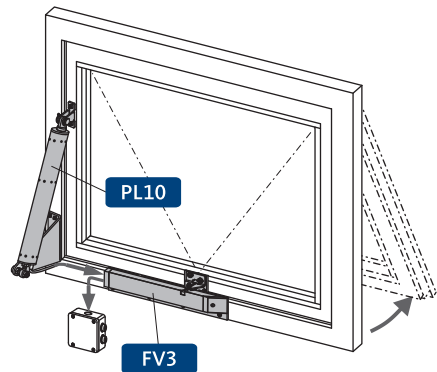

RWA 1100 Solo outward-opening
Shown on Side-Hung sash

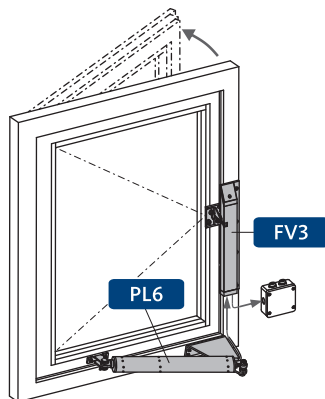

Tandem arrangement

RWA 1100 Tandem outward-opening
Shown on Top-Hung sash

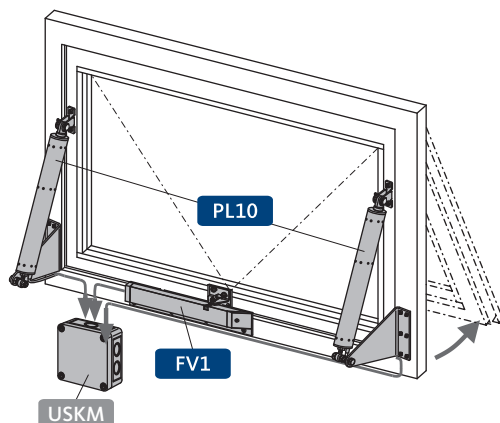

RWA 1100 hardware system

Installation dimensions



Installation dimensions of RWA 1100 on outward-opening Bottom-Hung and Top-Hung sashes

Door hardware	Mounting bracket	Travel Opening drive	Closed		Installation dimension "X" [1][2]	Sash external height	Opening angle	Opening width	
			Angle of attack Drive	Force application at point of attack					
				PL6					PL10
		[mm]	[DEG]	[N]	[N]	[mm]	[mm]	[DEG]	[mm]
SHEV 1100 [3]	K15	100	19	194	324	400	800	26	365
						500	900	23	360
						600	1000	18	320
		150	17	171	286	450	900	33	516
						550	1000	28	479
						650	1100	24	450
						750	1200	21	429
		200	15	153	255	500	1000	38	648
						600	1100	32	608
						700	1200	28	577
						800	1300	25	554
						900	1400	22	534
		250	13	139	232	550	1100	41	778
						650	1200	36	736
						750	1300	31	704
	850					1400	28	684	
	950					1500	25	657	
	1050					1600	23	638	
	250	12	127	211	600	1200	44	907	
					700	1300	39	861	
					800	1400	34	828	
					900	1500	31	799	
					1000	1600	28	777	
					1100	1700	26	756	
					1200	1800	24	742	
					K37	100	36	352	586
	300	700	28	342					
	400	800	21	296					
	150	31	312	520		250	650	42	527
						350	750	35	452
						450	850	28	407
						550	950	23	376
	200	28	279	465		300	750	52	659
						400	850	40	583
						500	950	24	390
						600	1050	28	499
						800	1150	24	474
	250	25	253	421		350	850	55	786
						450	950	44	712
						550	1050	37	661
650						1150	31	622	
750						1250	28	594	
850						1350	25	573	
300	23	231	384	400		1000	58	962	
				500		1100	47	879	
				600	1200	40	821		
				700	1300	35	775		
				800	1400	31	741		
				900	1500	28	713		
				1000	1600	25	693		

[1] Installation dimension X = distance from chain holding fixture F11 to hinge side (≥ 1/3 ESH)

[2] Other installation dimensions and sash heights available on request.

[3] For RWA 1100-TE the drive forces and sash weights must be correspondingly higher. With outward-opening sashes, the axis of the opening drives along which force is transmitted must run at least 25 mm from the centre of the hinge to the outside. The specified values apply for profile depths up to 75 mm.

[4] FV1 - 1-fold = 450 mm
 FV1 - 2-fold = 1200 or 2000 mm
 FV1 - 3-fold = 2000 mm

RWA 1100 hardware system

Installation dimensions



	Open		Max. sash weight		Space requirement on frame		Sash external width	
	Angle of attack Drive	Force application at point of attack						
		[DEG]	PL6 [N]	PL10 [N]	PL6 [kg]	PL10 [kg]	SCE [mm]	MCE [mm]
	67	554	923	55	92	40	40	depending on locking drive [4]
	64	537	896	60	100			
	60	519	865	62	104			
	75	580	966	58	97	-	40	
	69	559	932	61	103			
	66	549	914	65	108			
	63	536	894	67	112	40	40	
	79	590	983	59	98			
	74	577	962	63	105			
	71	566	943	66	110			
	88	600	999	74	123			
	66	546	910	70	117			
	82	595	991	60	99	40	40	
	78	586	976	63	106			
	74	576	961	66	111			
	72	571	952	69	116			
	69	559	932	71	118			
	67	552	921	72	121			
	85	598	996	60	100	40	40	
	80	591	985	64	106			
	77	584	973	67	111			
	74	576	960	69	115			
	72	569	948	71	119			
	70	563	938	73	121			
	68	557	928	74	124	40	40	
	94	599	998	40	67			
	80	591	985	51	84			
	73	573	955	57	96			
	97	595	992	46	76			
	85	598	996	56	93			
	78	586	976	62	103	40	40	
	73	573	955	66	111			
	99	593	988	47	79			
	88	600	999	56	94			
	81	593	988	62	104			
	76	583	972	67	111			
	73	573	956	70	116	40	40	
	100	591	984	49	81			
	90	600	1000	57	95			
	84	596	994	62	104			
	79	589	982	67	111			
	76	581	969	70	116			
	73	573	956	72	120	40	40	
	101	589	982	47	79			
	92	600	999	55	91			
	86	598	997	60	100			
	81	593	988	64	106			
	78	587	978	67	112			
	75	580	967	70	116	40	40	
	73	574	957	72	120			

RWA 1100 hardware system

Order information – version PL10 S1 + FV3-R (1-fold)



24V

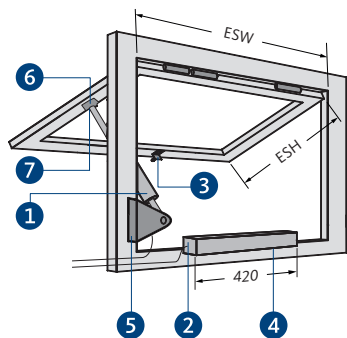

1 x PL10 S1
(100 / 150 / 200 / 300 mm)



1 x FV3-R or 1 x FV3-L (1-fold) L = 420 mm



B18 (incl.)



1 x B20-1 (420 mm)



1 x K15 set:

1 x K15

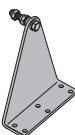

1 x F11



1 x B16ST (8x40)



Order information

Components		PU	Order number	
1 x spindle drive PL10 S1				
PL10-100	ESH min. 550 mm	1 pc	565010	
PL10-150	ESH min. 600 mm	1 pc	565015	
PL10-200	ESH min. 700 mm	1 pc	565020	
PL10-300	ESH min. 1000 mm	1 pc	565030	
1 x locking drive FV3 (Version R or L)				
FV3-R (1-fold)	Length = 420 mm ESW min. 450 mm	1 pc	515102	
FV3-L (1-fold)		1 pc	515105	
1 x connecting plate				
B20-1	Length = 420 mm	1 pc	515191	
1 x mounting bracket set				
K15 set		1 pc	517590	
Alternative to mounting bracket set K15 (1 x each)				
K37 mounting bracket		1 pc	307500	
F11 chain holding fixture		1 pc	151400	
Eyebolt B16ST		1 pc	100044	
Optional accessories				
B22 packer for B18		1 pc	301599	

Installation prerequisites

Opening direction	outward
Fixing dimension of drive (eye – eye)	280 ± 7 mm + travel
Space requirement of locking drive (FV)	min. 38 mm
Space requirement of spindle drive (PL)	min. 38 mm
Leaf weight	max. 30 kg/m ²
Sash external width	450–1300 mm
External sash height min.	see installation dimensions
Nominal voltage	24 V DC (19V ... 28V)
Breaking current	0.8 A
Rated output	15 W

RWA 1100-TE hardware system

Order information – version PL10 S1 + FV1-R (2-fold) + USKM



24V

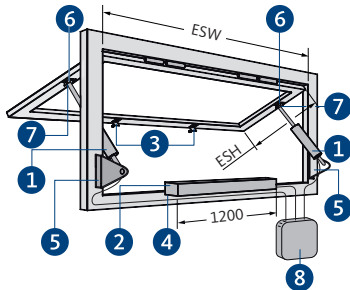

- 1 **2 x PL10 S1**
(100 / 150 / 200 / 300 mm)



- 2 **1 x FV1** (2-fold) L = 1200 mm



- 3 **2 x B18** (incl.)

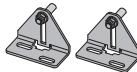

- 4 **1 x B20-2** (1200 mm)



2 x K15 set

- 5 **2 x K15**

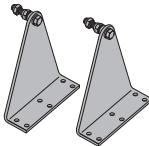

- 6 **2 x F11**

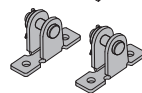

- 7 **2 x B16ST** (8x40)

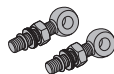

- 8 **1 x USKM**

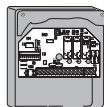

Order information

Components		PU	Order number	
2 x spindle drive PL10 S1				
PL10-100	ESH min. 550 mm	1 pc	565010	
PL10-150	ESH min. 600 mm	1 pc	565015	
PL10-200	ESH min. 700 mm	1 pc	565020	
PL10-300	ESH min. 1000 mm	1 pc	565030	
1 x locking drive FV1				
FV1-R (2-fold)	Length = 1200 mm ESW min. 1200 mm	1 pc	515111	
1 x connecting plate				
B20-2	Length = 1200 mm	1 pc	515193	
2 x mounting bracket set				
K15 set		1 pc	517590	
Alternative to mounting bracket set K15 (2 x each)				
K37 mounting bracket		1 pc	307500	
F11 chain holding fixture		1 pc	151400	
Eyebolt B16ST		1 pc	100044	
1 x inspection module				
USKM		1 pc	512140	
Optional accessories				
B22 packer for B18		1 pc	301599	

Installation prerequisites

Opening direction	outward
Fixing dimension of drive (eye – eye)	280 ± 7 mm + travel
Space requirement of locking drive (FV)	min. 40 mm
Space requirement of spindle drive (PL)	min. 38 mm
Leaf weight	max. 30 kg/m ²
Sash external width	1200–2500 mm
External sash height min.	see installation dimensions
Nominal voltage	24 V DC (19V ... 28V)
Breaking current	1.6 A
Rated output	30 W

RWA 1050 hardware system

Product characteristics



24V



Product characteristics

- For controlled natural ventilation, SHEV and NSHEV according to EN 12101-2
- Application at inward-opening Side-Hung sashes
- Opening angle up to 90° with short travels and opening times due to installation of spindle drives at an acute angle to the secondary closing edge, and shifting of the rotary fixing point to the mounting bracket behind the mullion/transom construction
- Low space requirement for installing mounting brackets on frame of only 22 mm
- Spindle drives can be combined in Solo or Tandem arrangement with different locking drives for actuation of profile-specific hardware systems

RWA 1050 hardware system

Mounting examples



Mounting examples: RWA 1050

Solo arrangement

RWA 1050 Solo inward-opening
Shown on Side-Hung sash

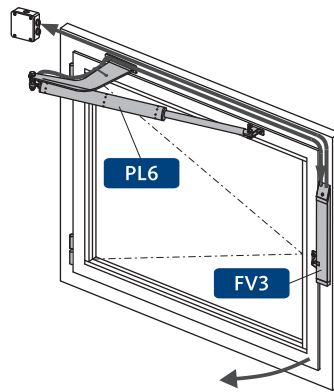

Tandem arrangement

RWA 1050 Tandem inward-opening
Shown on Side-Hung sash

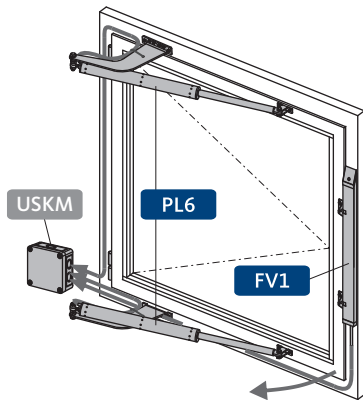

RWA 1050 Tandem inward-opening
Shown on Side-Hung sash

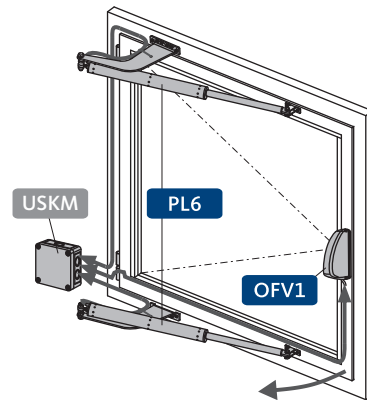

RWA 1050 hardware system

Installation dimensions



Installation dimensions of RWA 1050 on inward-opening Side-Hung sashes

Door hardware	Mounting bracket	Travel Opening drive	Closed		Installation dimension "x"	Min. exterior sash width	Opening angle	Opening width		
			Angle of attack Drive	Force application at point of attack						
				PL6						PL10
		[mm]	[DEG]	[N]	[N]	[mm]	[mm]	[DEG]	[mm]	
SHEV 1050 [1]	K97	100	19	167	279	0	510	35	[2]	
		150	13	139	232	20	600	55	[2]	
		200	11	119	198	40	680	75	[2]	
		250	10	103	172	80	740	85	[2]	

[1] For RWA 1050-TE the drive forces and sash weights are higher.

[2] Depending on the exterior sash width

RWA 1050 hardware system

Installation dimensions



	Open		Max. sash weight		Space requirement on frame:		Sash external height	
	Angle of attack Drive	Force application at point of attack						
		PL6	PL10	PL6	PL10	Hinge	SCE	MCE
	[DEG]	[N]	[N]	[kg]	[kg]	[mm]	[mm]	[mm]
	16	163	272	90	130	10	22	500-1500
	11	112	187	90	130	30	22	500-1500
	6	60	100	90	130	50	22	500-1500
	6	60	100	90	130	90	22	500-1500

RWA 1050 hardware system

Order information – version PL6 S1 + FV3-R (1-fold)

24V

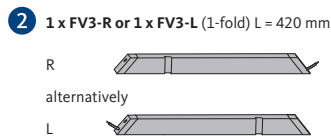
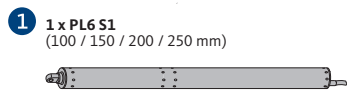
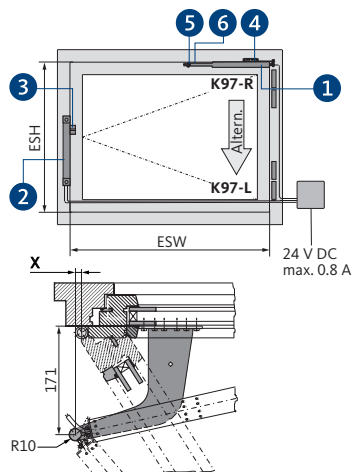

1 x K1050-R or alternatively 1 x K1050-L

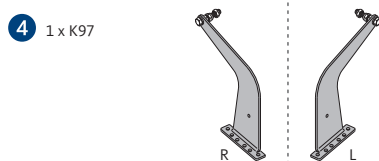

Order information

Components		PU	Order number	
1 x spindle drive PL6 S1				
PL6-100	ESW min. 510 mm	1 pc	562010	
PL6-150	ESW min. 600 mm	1 pc	562015	
PL6-200	ESW min. 680 mm	1 pc	562020	
PL6-250	ESW min. 740 mm	1 pc	562025	
1 x locking drive FV3 (Version R or L)				
FV3-R (1-fold)	Length = 420 mm ESW min. 450 mm	1 pc	515102	
FV3-L (1-fold)		1 pc	515105	
1 x mounting bracket set				
K1050-R-Set		1 pc	307051	
Alternative to mounting bracket set K1050-R				
K1050-L-Set		1 pc	307050	
Optional accessories				
B22 packer for B18		1 pc	301599	

Installation prerequisites	
Opening direction	inward
Fixing dimension of drive (eye – eye)	280 ± 7 mm + travel
Space requirement of locking drive (FV)	min. 38 mm
Space requirement of spindle drive (PL)	min. 20 mm
Leaf weight	max. 30 kg/m ²
Sash external width	450–1300 mm
External sash height min.	see installation dimensions
Nominal voltage	24 V DC (19V ... 28V)
Breaking current	0.8 A
Rated output	15 W

RWA 1050 hardware system

Order information – version PL6 S1 + OFV1



24V

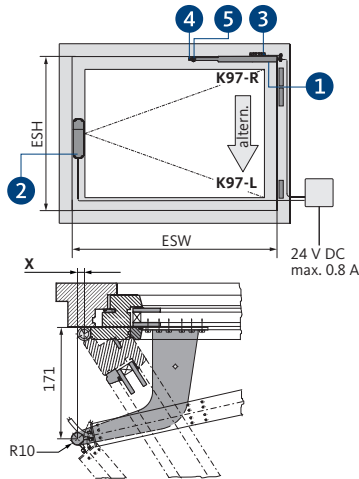

1 1 x PL6 S1
(100 / 150 / 200 / 250 mm)



2 1 x OFV1



1 x K1050-R or alternatively 1 x K1050-L

3 1 x K97

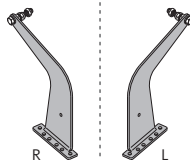

4 1 x F11



5 1 x B16ST (8x40)



Order information

Components		PU	Order number	
1 x spindle drive PL6 S1				
PL6-100	ESW min. 510 mm	1 pc	562010	
PL6-150	ESW min. 600 mm	1 pc	562015	
PL6-200	ESW min. 680 mm	1 pc	562020	
PL6-250	ESW min. 740 mm	1 pc	562025	
1 x locking drive OFV				
OFV1	ESH min. 450 mm	1 pc	513850	
1 x mounting bracket set				
K1050-R-Set		1 pc	307051	
Alternative to mounting bracket set K1050-R				
K1050-L-Set		1 pc	307050	

Installation prerequisites	
Opening direction	inward
Fixing dimension of drive (eye – eye)	280 ± 7 mm + travel
Space requirement of locking drive (OFV) on sash frame	min. 40 mm
Space requirement of spindle drive (PL) on window frame	min. 20 mm
Leaf weight	max. 30 kg/m ²
Sash external width	1200–2500 mm
External sash height min.	see installation dimensions
Nominal voltage	24 V DC (19V ... 28V)
Breaking current	1.6 A
Rated output	30 W

RWA 1050-TE hardware system

Order information – version PL6 S1 + FV1-R (1- or 2-fold) + USKM



24V

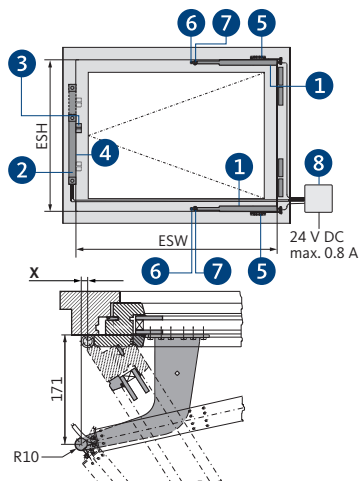

1 2 x PL6 S1
(100 / 150 / 200 / 250 mm)



2 1 x FV1-R or 1 x FV1-L (1-fold) L = 420 mm



alternatively:
1 x FV1-R (2-fold) L = 1200 mm



3 B18 (incl.)
1 x L = 420 mm
2 x L = 1200 mm

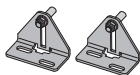

4 1 x B21-1 (L = 420 mm)
alternatively:
1 x B21-2 (L = 1200 mm)



2 x K1050-Set (1 x R / 1 x L)

5 2 x K97

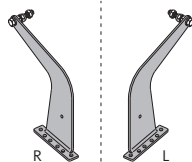

6 2 x F11

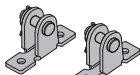

7 2 x B16ST (8x40)

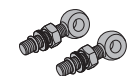

8 1 x USKM

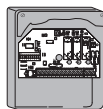

Order information

Components		PU	Order number	
2 x spindle drive PL6 S1				
PL6-100	ESW min. 510 mm	1 pc	562010	
PL6-150	ESW min. 600 mm	1 pc	562015	
PL6-200	ESW min. 680 mm	1 pc	562020	
PL6-250	ESW min. 740 mm	1 pc	562025	
1 x locking drive FV1 (Version R or L)				
FV1-R (1-fold)	Length = 420 mm ESW min. 450 mm	1 pc	515103	
FV1-L (1-fold)		1 pc	515106	
Alternative to locking drives FV1 (1-fold)				
FV1-R (2-fold)	Length = 1200 mm ESW min. 1200 mm	1 pc	515111	
1 x connecting plate				
B21-1	Length = 420 mm Sash overlap = > 10 mm	1 pc	515181	
B21-2	Length = 1200 mm Sash overlap = > 10 mm	1 pc	515183	
2 x mounting bracket set				
K1050-R-Set		1 pc	307051	
K1050-L-Set		1 pc	307050	
1 x inspection module				
USKM		1 pc	512140	
Optional accessories				
B22 packer for B18		1 pc	301599	

Installation prerequisites

Opening direction	inward
Fixing dimension of drive (eye – eye)	280 ± 7 mm + travel
Space requirement of locking drive (FV)	min. 38 mm
Space requirement of spindle drive (PL)	min. 20 mm
Leaf weight	max. 30 kg/m ²
Sash external width	450–1300 mm
External sash height min.	see installation dimensions
Nominal voltage	24 V DC (19V ... 28V)
Breaking current	0.8 A
Rated output	15 W

RWA 1050-TE hardware system

Order information – version PL6 S1 + OFV1 + USKM



24V

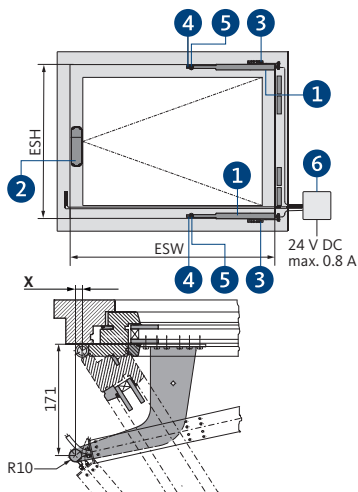

1 2 x PL6 S1
(100 / 150 / 200 / 250 mm)

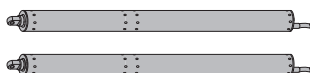

2 1 x OFV1



2 x K1050-Set (1 x R / 1 x L)

3 2 x K97

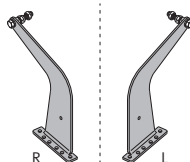

4 2 x F11

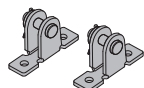

5 2 x B16ST (8x40)

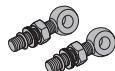

6 1 x USKM

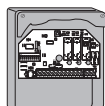

Order information

Components		PU	Order number	
2 x spindle drive PL6 S1				
PL6-100	ESW min. 510 mm	1 pc	562010	
PL6-150	ESW min. 600 mm	1 pc	562015	
PL6-200	ESW min. 680 mm	1 pc	562020	
PL6-250	ESW min. 740 mm	1 pc	562025	
1 x locking drive OFV				
OFV1	ESH min. 450 mm	1 pc	513850	
2 x mounting bracket set				
K1050-R-Set		1 pc	307051	
K1050-L-Set		1 pc	307050	
1 x inspection module				
USKM		1 pc	512140	

Installation prerequisites	
Opening direction	inward
Fixing dimension of drive (eye – eye)	280 ± 7 mm + travel
Space requirement of locking drive (OFV) on sash frame	min. 40 mm
Space requirement of spindle drive (PL) on window frame	min. 20 mm
Leaf weight	max. 30 kg/m ²
Sash external width	1200–2500 mm
External sash height min.	see installation dimensions
Nominal voltage	24 V DC (19V ... 28V)
Breaking current	1.6 A
Rated output	30 W





1.6 Accessories

Configuration modules M-COM and M-COM Click	222
Click plug solution Wire Click	223
Click plug solution Connect Click	224
Portable test set	224
Power supply units NT 1.7 and NT3	225
GU restrictor stays	226
Custom-made products	228
Hardware and software for drive configuration	230

Accessories

Configuration modules M-COM and M-COM Click



M-COM configuration module

for chain drives KS2 | KS4 | KSA | KS15
for FVUx | OFV1 M-COM locking drives
for PLA | PLS spindle drives
for FTA600 flap lever drives

Application

- Configuration module for automatic configuration and monitoring of max. 4 opening and 2 locking drives in version S12 in interconnected drive systems
- Populated PCB with connecting wires for installation in connection socket to be provided by customer

Technical data	
Nominal voltage	24 V DC (19 V ... 28 V)
Power consumption	< 12 mA
Protection code	IP30 rubber-sheathed
Ambient temperature	0 °C to +70 °C
Dimensions	45 x 17 x 6 mm
Connecting wires	3 wires 0.5 mm ² x 50 mm

	PU	Order number	
	1 pc	524177	



M-COM Click configuration module

for KS4 | KSA chain drives

Application

- Configuration module for automatic configuration and monitoring of max. 4 opening and 2 locking drives in version S12 in interconnected drive systems

Technical data	
Nominal voltage	24 V DC (19 V ... 28 V)
Power consumption	< 12 mA
Protection code	IP30
Ambient temperature	-5 °C to +70 °C
Dimensions	40 x 26 x 15 mm

	PU	Order number	
	1 pc	524167	

Accessories

Click plug solution Wire Click



Wire Click

for KS4 | KSA | KS15 chain drives
for FTA600 flap lever drives

Product characteristics

- Flexible cable length
- Connection of several drives
- Twist-proof plug
- Latching hooks prevent the connector from being pulled off under tensile loading
- Strain relief by screwing the closer body parts in accordance with DIN EN 60335-1

Click plug solution – 24 V	For drives	PU	Order number	
3 m – halogen-free, grey – 5 x 0.5 mm ²	KS4 FTA600	1 pc	501251	
5 m – halogen-free, grey – 5 x 0.5 mm ²	KS4 KSA FTA600	1 pc	501252	
10 m – halogen-free, grey – 5 x 0.5 mm ²	KS4 KSA FTA600	1 pc	501253	
5 m – halogen-free, grey – 5 x 1.0 mm ²	KS15	1 pc	501290	
Click plug solution – 230 V	For drives	PU	Order number	
3 m – halogen-free, grey – 6 x 0.75 mm ²	KSA	1 pc	501273	
5 m – halogen-free, grey – 6 x 0.75 mm ²	KSA	1 pc	501275	
10 m – halogen-free, grey – 6 x 0.75 mm ²	KSA	1 pc	501280	
5 m – halogen-free, grey – 6 x 0.75 mm ²	KS15	1 pc	501292	

Accessories

Click plug solution Connect Click, portable test set

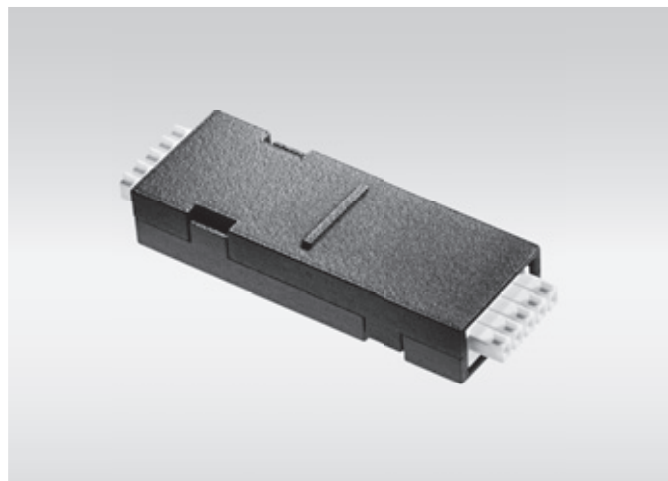

Connect Click

for KS4 chain drives

Application

- Connecting plug for fixed mounting of two drives with mirrored chain outlet

Product characteristics

- Twist-proof plug
- Replaces intrusive cable
- Visually-consistent appearance of window without intrusive visible cable

Technical data	
Nominal voltage	24 V DC (19 V ... 28 V)
Dimensions	70 x 26 x 13 mm

	PU	Order number	
	1 pc	524123	



Portable test set

- For operating 24 V DC/230 V AC drives
- Digital display of maximum and instantaneous current
- Separate 24 V and 230 V power connections
- Push-to-lock switch and dead man's switch
- Integrated battery pack
- With deep discharge protection/automatic switch-off after 30 minutes without actuation for protection of the batteries
- Switching capacity: 24-V drives up to 5 A / 230-V drives up to 4 A

Technical data	
Dimensions (W x H x D)	250 x 250 x 210 mm
Weight	3.6 kg
Cylinder body	PVC

	PU	Order number	
	1 pc	K-17736-00-0-6	

Accessories

Power supply unit NT 1.7 | Power supply unit NT 3

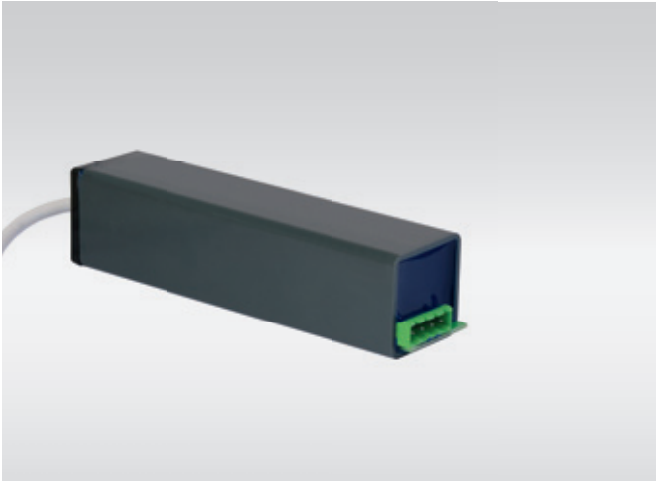

NT1.7 power supply unit

- For voltage supply and control of chain drives and locking drives for ventilation purposes
- Connection of up to two drives
- Power-up / connection possible (directional change)

Technical data	
Supply voltage	230 V AC
Output current	1.7 A
Nominal power	50 VA
Duty ratio	30 %
Dimensions (W x H x D)	145 x 35 x 35 mm
Protection code	IP20

	PU	Order number
	1 pc	6-37487-01-0-0

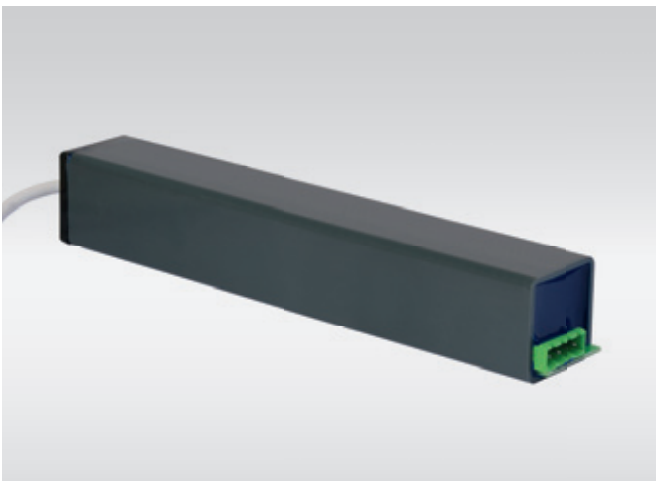

NT3 power supply unit

- For voltage supply and control of chain drives and locking drives for ventilation purposes
- Connection of up to two drives
- Power-up / connection possible (directional change)

Technical data	
Supply voltage	230 V AC
Output current	3 A
Nominal power	95 VA
Duty ratio	30 %
Dimensions (W x H x D)	245 x 35 x 35 mm
Protection code	IP20

	PU	Order number
	1 pc	6-37487-21-0-0

Accessories

GU restrictor stays for metal windows



GU restrictor stays

- The RAL directives and the technical rules of the ASR A 1.6 workplaces stipulate: Bottom-Hung sashes must be equipped with restrictor stays in addition to the drive system.
- The GU restrictor stays prevent damage that could occur due to improper hinging of the chain drives on the sash. They permanently connect the sash to the frame and therefore provide additional operating safety, whilst also preventing the sash from falling.
- Use on large and heavy Bottom-Hung windows up to 250 kg
- Safety catch function only (no cleaning function)
- Can be used with locking drives*

Technical data	
Opening type	Bottom-Hung window
Opening direction	inward

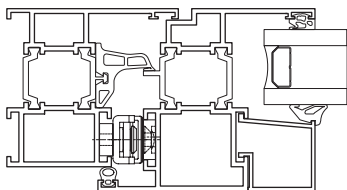

Without vertical locking

size	Travel	SH min.	Order number
01	300 mm	320 mm	K-17915-01-0-8
	400 mm	400 mm	
size	Travel	SH min.	Order number
00	500 mm	500 mm	K-17915-00-0-8
	600 mm	800 mm	

With vertical locking

size	Travel	SH min.	Order number
01	300 mm	900 mm	K-17915-01-0-8
	400 mm	650 mm	
size	Travel	SH min.	Order number
00	400 mm	2000 mm	K-17915-00-0-8
	500 mm	1100 mm	

* The application information for use with locking drives can be found in the respective installation instructions

Accessories

GU restrictor stays for timber windows

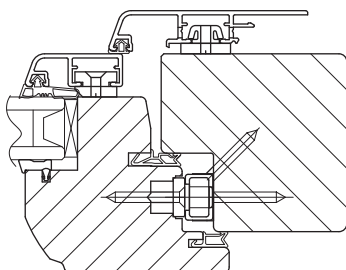

GU restrictor stays

- The RAL directives and the technical rules of the ASR A 1.6 workplaces stipulate: Bottom-Hung sashes must be equipped with restrictor stays in addition to the drive system.
- The GU restrictor stays prevent damage that could occur due to improper hinging of the chain drives on the sash. They permanently connect the sash to the frame and therefore provide additional operating safety, whilst also preventing the sash from falling.
- Use on large and heavy Bottom-Hung windows up to 250 kg
- Safety catch function only (no cleaning function)
- Can be used with locking drives*

Technical data	
Opening type	Bottom-Hung window
Opening direction	inward

Without vertical locking			
size	Travel	SH min.	Order number
01	300 mm	550 mm	K-17915-01-0-8
	400 mm	770 mm	
size	Travel	SH min.	Order number
00	500 mm	690 mm	K-17915-00-0-8
	600 mm	700 mm	

With vertical locking			
size	Travel	SH min.	Order number
00	400 mm	1101 mm	K-18046-00-0-8
	500 mm	1001 mm	

* The application information for use with locking drives can be found in the respective installation instructions

Accessories

Custom-made product: painting/powder-coating



Painting/powder-coating in RAL colours

for KS2 | KS4 | KSA | KS15 chain drives

for FVUx locking drives





for PLA | PLS | SP spindle drives

for FTA600 flap lever drives

Our drives and fixings are also available in a range of special colours. Individual design solutions and colour concepts can thus be realised throughout the entire building.





Order information

Drive housing painted in RAL colours

Painting lump sum		516030	
With order of	1 – 20	516004	
	21 – 50	516004	
	51 – 100	516004	
	from 101	516004	





Order information

Chain holding fixtures painted/powder-coated in RAL colours

Painting lump sum		516030	
With order of	1 – 20	516032	
	21 – 50	516032	
	51 – 100	516032	
	from 101	516032	

Order information

Mounting brackets painted/powder-coated in RAL colours

Painting lump sum		516030	
With order of	1 – 20	516031	
	21 – 50	516031	
	51 – 100	516031	
	from 101	516031	

Accessories

Custom-made product: programming of S12 microprocessor



Programming of S12 microprocessor

for KS2 | KS4 | KSA | KS15 chain drives

for FVUx locking drives

for PLA | PLS | SP spindle drives

for FTA600 flap lever drives

Programmable parameters of the intelligent S12 control electronics:

- Synchronised multiple operation and sequential control
- Soft start and soft stop at the end positions
- Travel, closing force, speed
- Reversing in the event of overload cut-off during the closing operation
- Checkback signal for "OPEN" and/or "CLOSE" end position (depending on drive type)

Order information

Programming of S12 microprocessor	
Electronic lift shortening 24V S12	524190
Electronic lift shortening 230V S12	495590
Programming of 24V / 230V S12 drives	524180
Programming of 230V S12 interconnected drives (per drive)	495588

Accessories

Hardware and software for drive configuration



Hardware and software "Drives"

- Hardware and software for programming the KS2, KS4, KSA and KS15 drives
- 24 V DC power supply is not included in the scope of delivery
- A software license is required to make advanced settings

Technical data	
Nominal voltage	24 V DC ± 20 %
Programmable drives	24 V DC in version S12 V.2 230 V AC in version S12 V.2
Connections	3 x screw-type plug terminals 1.0 mm ² USB connection
Minimum system requirements	
CPU	1 GHz or faster
OS	Microsoft® Windows 7 / Windows 10
Total frame width	min. 512 MB
HDD	min. 100 MB available

PU	Order number	
1 pc	524178	
Scope of delivery: 1 x Software Drives (Downloadlink), Interface "ParInt", USB cable, connecting cable		







2.0 Control technology

2.1 Compact control units RZ

RZ25 | RZ50 | RZ75 | accessories 236

2.2 Compact control units EMB

EMB7300 252

2.3 Modular control units EMB

EMB8000+ 268

2.4 Accessories for SHEV

For EMB7300 and EMB8000+ SHEV central control units 292

2.5 Ventilation control units

LZ1 | LZ6 302

2.6 Ventilation accessories

Manual ventilation 308

2.7 Ventilation accessories

Automatic ventilation 310

Electric control units (24 V)

Product overview



Designation		Compact control units RZ			Compact control units EMB7300			
Head office		RZ25	RZ50	RZ75	2.5 A	5 A	10 A	20 A
Page		236 – 251			252 – 267 + 292 – 300			
VdS-tested		-			■			
Output current		3.2 A	6.5 A	8.4 A	2.5 A	5 A	10 A	20 A
Max. number of SHEV groups		1			1	1	2	2
Max. number of ventilation groups		1			1	2	4	4
Connection of several central control units		up to 5 [1]			-			
Alarm line 1: Manual triggering	Max. Number of SHEV push-buttons HSE	10			10			
Alarm line 2: Automatic triggering	Max. Number of smoke / heat detectors	10			10			
	Triggering via FAS [2]	optional			optional			
Alarm line 3: External signals	z. B. Triggering via FAS	-			-			
Ventilation control	Ventilation push-button	any (without LED) 10 (with LED)			any (without LED) 10 (with LED)			
	Connection of wind/rain detectors	[3]	[4]	[4]	[4]			
Potential-free Alarm contact	Alarm	-	■	■	[6]			
	Interference	-	■	■	[6]			
Automatic ventilation CLOSED		■			■			
Backup batteries		included			must be ordered separately			
Protection code		IP 20 / IP 54 [7]			IP 40			
Surface-mounted housing		sheet-steel, RAL 9010			sheet-steel, RAL 7035			
Ambient temperature		-5 to +40 °C			-5 to +40 °C			
Ventilation changeover: from deadman to latching		■			via licence software available free of charge			
Configuration: wind sensor switching threshold		■			via licence software available free of charge			
Limitation: drive runtime / travel for ventilation operation		■			via licence software available free of charge			
Configuration and activation of time-controlled automatic closing		■			via licence software subject to a fee			
Activation: closing operation in the event of mains failure		■			via licence software available free of charge			
Setting: acoustic/visual warning signal		■			via licence software subject to a fee			
Changeover: EMERGENCY CLOSE push-button: from latching to deadman		-			via licence software available free of charge			
Configuration: time service/maintenance is next due		-			via licence software subject to a fee			
Alarm reset: after FACP signal drops out		-			via licence software subject to a fee			
Configuration: switch-off time of drive line		-			via licence software subject to a fee			
Changeover of drive running direction: in the event of alarm from opening to closing		■			via licence software subject to a fee			

Electric control units (24 V)

Product overview



Modular control units EMB8000+						
5 A	10 A	24 A	48 A	72 A	96 A	
268 – 291 + 292 – 300						
■						
5 A	10 A	24 A	48 A	72 A	96 A	
depending on available module units						
depending on available module units						
Optional						
10 per line, max. 60 + max. 30 BUS participants						
10 per line, max. 60 + max. 30 BUS participants						
-						
1 x FACP signal (external fire alarm system)						
any (without LED) 10 (with LED)						
[5]						
via licence software subject to a fee						
via licence software subject to a fee						
■						
must be ordered separately						
IP 54						
sheet-steel, RAL 7035						
-5 to +40 °C						
via licence software subject to a fee						
via licence software subject to a fee						
via licence software subject to a fee						
via licence software subject to a fee						
via licence software subject to a fee						
via licence software subject to a fee						
via licence software subject to a fee						
via licence software subject to a fee						
via licence software subject to a fee						
via licence software subject to a fee						
via licence software subject to a fee						
via licence software subject to a fee						
via licence software subject to a fee						
via licence software subject to a fee						

- [1] 1 SHEV group and 5 ventilation groups
- [2] Via line terminal module/interfaces module for FAS
- [3] Only rain detector
- [4] Without additional module, with integrated evaluation and wind measurement (adjustable wind speed)
- [5] Via weather module (WM)
- [6] Only via relay module REL 65
- [7] With IP54 protection code set

SHEV control unit RZ

Product characteristics



Product characteristics

- Smoke and heat exhaust ventilation control panel with compact design for stairwells, for control of electromechanical SHEV and ventilation drives with 24 V DC operating voltage
- TÜV-tested with reference to EN 12101-9/10
- Regulated output voltage
- Connection of up to 5 central control units, with real cable monitoring
 - up to five physically separate ventilation groups
 - Central ventilation push-button function for all connected central control systems
- Comfortable and clear status, error and fault signalling via LED indicators
- Wide range of adjustment and application functions
- Relay outputs for alarm and interference (RZ50 and RZ75)
- Connection of rain detector
 - RZ25: without auxiliary module
 - RZ50 / RZ75: without auxiliary module, with integrated evaluation and wind measurement (adjustable wind speed)
- Easy installation, start-up, service and maintenance
- Maintenance interval: signal for yearly maintenance/inspection
- Connection to the BKS-NET-BUS (via the I/O module IO10)
- Connection to a FACP (via the interface module)
- Compact, robust steel housing

SHEV control unit RZ

Technical data / performance scope of software



Technical data / performance scope of software

Specification		RZ25	RZ50	RZ75
Operating voltage		100 – 240 V AC	100 – 240 V AC	100 – 240 V AC
Nominal voltage		26 V	26 V	26 V
Output current		3.2 A	6.5 A	8.4 A
Frequency		50 – 60 Hz	50 – 60 Hz	50 – 60 Hz
Connection of several central control units		up to 5 [1]	up to 5 [1]	up to 5 [1]
Alarm line 1: manual triggering	Max. number of SHEV push-buttons	10	10	10
Alarm line 2: automatic triggering	Max. number of smoke/heat detectors	10	10	10
	Triggered via FAS [2]	optional	optional	Optional
Alarm line 3: external signals	e.g. triggered via FAS	-	-	-
Ventilation control	Ventilation push-button	any (without LED) 10 (with LED)	any (without LED) 10 (with LED)	any (without LED) 10 (with LED)
	Connection of wind/rain detector	[3]	[4]	[4]
Potential free signal contacts (alarm and interference)		-	■	■
Automatic ventilation CLOSED		■	■	■
Dead man's function in ON and OFF direction		■	■	■
Runtime limitation for ventilation (adjustable)		■	■	■
Automatic closing of windows in case of power failure		■	■	■
Ambient temperature		-5 °C to +40 °C	-5 °C up to +40 °C	-5 °C to +40 °C
Protection code		IP20 / IP54 [5]	IP20 / IP54 [5]	IP20 / IP54 [5]
Cylinder body		Surface-mounted, sheet steel, RAL 9010	Surface-mounted, sheet steel, RAL 9010	Surface-mounted, sheet steel, RAL 9010
Dimensions (W x H x D)		296 x 296 x 112 mm	296 x 296 x 112 mm	296 x 296 x 112 mm
Dimensions (W x H x D) with IP 54 installation kit		335 x 296 x 116 mm	335 x 296 x 116 mm	335 x 296 x 116 mm
Backup batteries		included (2 x 2.3 Ah)	included (2 x 3.2 Ah)	included (2 x 3.2 Ah)
Connection cross-section for mains cable		2.5 mm ²	2.5 mm ²	2.5 mm ²
Connection cross section for drive line [6]		4 mm ²	4 mm ²	4 mm ²

[1] 1 SHEV group and 5 ventilation groups | [2] via line terminal module/interfacing module for FAS

[3] rain detectors only | [4] without additional module, with integrated evaluation and wind measurement (adjustable wind speed)

[5] with IP54 protection set | [6] with pluggable terminals

SHEV control unit RZ

Order information – version RZ25 | RZ50 | RZ75



Order information

Specification	PU	Order number
RZ25* incl. batteries	1 pc	K-18328-00-0-7
Contents: 1 x RZ25 compact control unit, 2 x rechargeable battery 2.3 Ah		
RZ25* without batteries	1 pc	K-19817-00-0-7
Contents: 1 x RZ25 compact control unit		

1 SHEV group / 1 ventilation group



Order information

Specification	PU	Order number
RZ50* incl. batteries	1 pc	K-18329-00-0-7
Contents: 1 x RZ50 compact control unit, 2 x rechargeable battery 3.2 Ah		
RZ50* without batteries	1 pc	K-19818-00-0-7
Contents: 1 x RZ50 compact control unit		

1 SHEV group / 1 ventilation group



Order information

Specification	PU	Order number
RZ75* incl. batteries	1 pc	K-18433-00-0-7
Contents: 1 x RZ75 compact control unit, 2 x rechargeable battery 3.2 Ah		
RZ75* without batteries	1 pc	K-19819-00-0-7
Contents: 1 x RZ75 compact control unit		

1 SHEV group / 1 ventilation group

* Any combination of up to 5 compact control units (RZ25, RZ50 and RZ75) can be interlinked.

SHEV control unit RZ

Order information – Accessories



Line terminal module/interface module for FAS

Application

- Line terminal module: for drive line monitoring
- Interfacing module: for triggering of alarm via a FACP

	PU	Order number
	1 pc	9-48836-00-0-0



BKS-NET coupling module

Application

- For the connection of multiple central control units
- Installation only in the slave control unit

	PU	Order number
	1 pc	9-48897-00-0-0

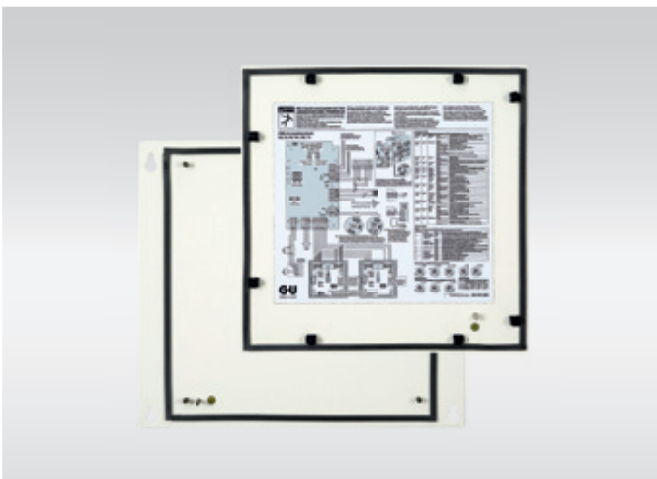

IP installation kit

Application

- For achievement of IP 54 protection code

	PU	Order number
	1 pc	K-18830-00-0-7
Contents: 1 x wall mounting plate, 1 x cover		

SHEV control unit RZ

Order information – Accessories



Backup batteries

- For maintaining SHEV control units in standby mode for a period of 72 hours

Note

- 2 batteries are always required per control unit

Technical data	
Min. operating voltage	12 V DC

Capacity	PU	Order number
2.3 Ah, 12 V	1 pc	9-47475-00-0-0
3.2 Ah, 12 V	1 pc	9-48529-00-0-0

SHEV control unit RZ

Order information – Accessories



Plastic housing



Aluminium housing

SHEV push-button 'HSE'

Application

- Push-button fire alarm switch for manual triggering of alarm via the SHEV control unit in the event of fire

Product characteristics

- Push-button: EMERGENCY OPEN and reset: CLOSE
- LED status indication for EMERGENCY OFF (red), operation (green), interference (yellow)
- Removable glass pane
- Including keys
- Installation: in escape routes and corridors, clearly visible and freely accessible, installation height 1.4 m ± 20 cm above the floor

Technical data	
Protection code	IP50
Dimensions (W x H x D)	125 x 125 x 36 mm

Specification	PU	Order number
Plastic housing		
orange (sim. to RAL 2004)	1 pc	6-37311-00-0-9x
red (sim. to RAL 3000)	1 pc	6-37311-00-0-9
yellow (sim. to RAL 1018)	1 pc	6-37311-00-0-3
grey (sim. to RAL 7040)	1 pc	6-37311-00-0-1
blue (sim. to RAL 5005)	1 pc	6-37311-00-0-0

Specification	PU	Order number
Aluminium housing		
orange (sim. to RAL 2004)	1 pc	6-37312-00-0-9x
red (sim. to RAL 3000)	1 pc	6-37312-00-0-9
yellow (sim. to RAL 1018)	1 pc	6-37312-00-0-3
grey (sim. to RAL 7040)	1 pc	6-37312-00-0-1
blue (sim. to RAL 5005)	1 pc	6-37312-00-0-0

SHEV control unit RZ

Order information – Accessories



Replacement key

Application

- For opening and closing the door of 125 x 125 x 36 mm HSE push-buttons

Order number	PU	Order number
PVC	1 pc	9-48552-00-0-6

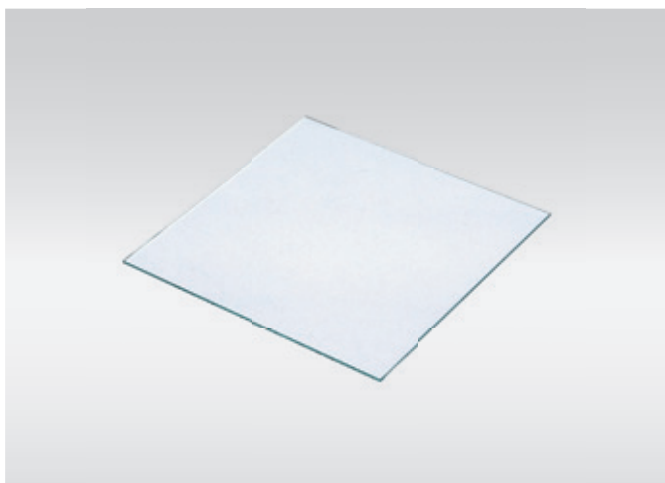

Replacement glass

Application

- Glass panel for on-site replacement
- Suitable for 125 x 125 x 36 mm HSE push-buttons

	PU	Order number
	1 pc	9-42235-00-0-0

SHEV control unit RZ

Order information – Accessories



Sticker "Smoke exhaust" – language versions for SHEV push-button HSE

Language	PU	Order number
English	1 pc	K-19015-01-0-0
French	1 pc	K-19015-02-0-0
Spanish	1 pc	K-19015-03-0-0
Italian	1 pc	K-19015-04-0-0
Dutch	1 pc	K-19015-05-0-0
Polish	1 pc	K-19015-06-0-0
Russian	1 pc	K-19015-07-0-0
Czech	1 pc	K-19015-08-0-0
Turkish	1 pc	K-19015-09-0-0
Chinese	1 pc	K-19015-10-0-0
Croatian	1 pc	K-19015-11-0-0
Serbian	1 pc	K-19015-12-0-0
Romanian	1 pc	K-19015-13-0-0
Contents: 5 x sheets each with 5 stickers (= 25 pcs)		

SHEV control unit RZ

Order information – Accessories



RMD3 smoke detector

Application

- For automatic early detection of fire and to trigger the alarm via the SHEV central control unit in the event of fire

Product characteristics

- Intelligent evaluation and cut-off mode for disturbances to prevent false alarms
- Tested and DIBt-approved according to EN 54-7
- Including mounting base

Technical data	
Nominal voltage	24 V
Operating voltage	9–33 V DC
Protection code	IP40
Fail-safe	100 µA
Alarm current	20 mA
Height	44 mm
Diameter	100 mm
Cylinder body	PVC

Finish	PU	Order number
White	1 pc	K-18883-00-0-0



Test gas for smoke detectors

Application

- To perform a quick functional test on smoke detectors

Product characteristics

- To spray directly in the smoke chamber
- Non-inflammable

Contents	PU	Order number
250 ml	1 pc	K-17497-00-0-0

*ATTENTION: Do not use in spaces with high build-up of dust, smoke or vapour.

SHEV control unit RZ

Order information – Accessories



WMD3 heat detector

Application

- For automatic early detection of fire and to trigger the alarm via the SHEV central control unit in the event of fire

Product characteristics

- Intelligent evaluation and cut-off mode for disturbances to prevent false alarms
- Tested in accordance with EN 54-5
- Multi-coloured LED for alarm (red) and fault display (yellow)
- Including mounting base
- Thermal measuring unit with evaluation according to the differential and maximal procedure

Technical data	
Nominal voltage	24 V
Operating voltage	9–33 V DC
Protection code	IP40
Fail-safe	100 µA
Alarm current	20 mA
Height	44 mm
Diameter	100 mm
Cylinder body	PVC

Finish	PU	Order number
White	1 pc	K-18884-00-0-0

*ATTENTION: Do not use in spaces with high build-up of dust, smoke or vapour.

SHEV control unit RZ

Order information – Accessories



Ventilation spring-operated key switch ON – STOP – OFF

Product characteristics

- Prepared for profile half cylinder

Technical data	
Dimensions (W x H x D)	80 x 152 x 35 mm

Specification	PU	Order number
In-wall version	1 pc	6-25838-00-0-0



Ventilation push button ON – OFF

Technical data		
Width	80 mm	
Height	80 mm	
Depth	On-wall version	44 mm
	In-wall version	35 mm
Surface	pearl white (RAL 1013)	

Specifications	PU	Order number
On-wall version	1 pc	6-24372-00-0-0
Flush-mounted*	1 pc	6-24373-00-0-0

*For installation in flush-mounted cans Ø 60 mm.

SHEV control unit RZ

Order information – Accessories

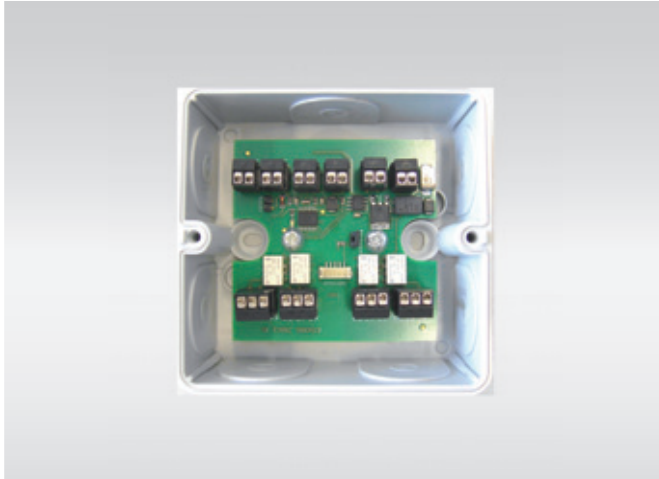

Input/output module IO10

Application

- To make inputs and outputs available to the central control unit

	PU	Order number
	1 pc	B 5580 0321

SHEV control unit RZ

Order information – Accessories



ST10 spring-operated key switch

Application

- Central operating unit for the central control systems networked via the BKS-NET interface

Version*	PU	Order number
without LEDs	1 pc	B 5580 0311



ST20 spring-operated key switch

Application

- Central operating unit for the central control systems networked via the BKS-NET interface

Version*	PU	Order number
with LEDs	1 pc	B 5580 0312

*Locking cylinder, frame and covers must be ordered separately (see following pages)

SHEV control unit RZ

Order information – Accessories



Locking half cylinder series 88 for ST10, ST20 key switches

Product characteristics

- including 3 keys

Specification	PU	Order number
31 mm	1 pc	B 8900 0101

SHEV control unit RZ

Order information – Accessories

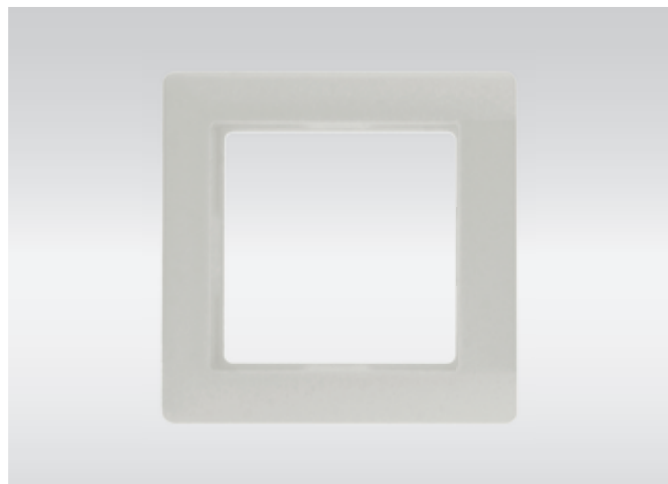

Frame AS500 (55 mm)
for ST10, ST20 key switches

Specification	Finish	PU	Order number
1-fold	Alpine white	1 pc	B 5858 1071
2-fold	Alpine white	1 pc	B 5858 1072



Frame LS990 (70 mm)
for ST10, ST20 key switches

Specification	Finish	PU	Order number
1-fold	Stainless steel look	1 pc	B 5858 0481
1-fold	Alpine white	1 pc	B 5858 0471
2-fold	Stainless steel look	1 pc	B 5858 0482
2-fold	Alpine white	1 pc	B 5858 0472

SHEV control unit RZ

Order information – Accessories

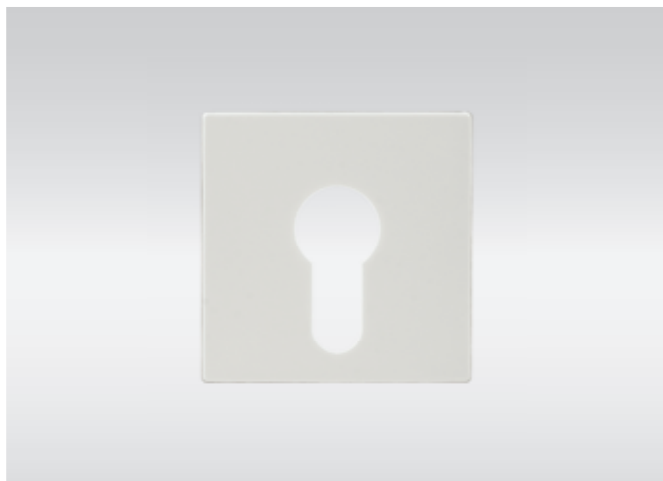

Cover AS500 (55 mm)
for ST10, ST20 key switches

Specification	Finish	PU	Order number
ST10	Alpine white	1 pc	B 5858 0873
ST20	Alpine white	1 pc	B 5858 0874

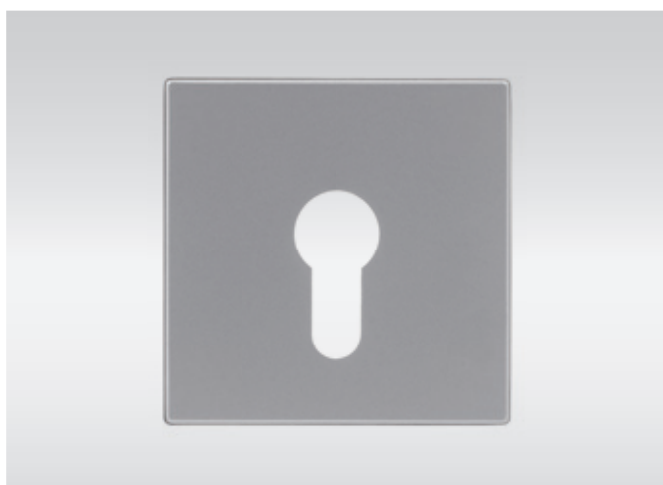

Cover LS990 (70 mm)
for ST10, ST20 key switches

Specification	Finish	PU	Order number
ST10	Stainless steel look	1 pc	B 5858 0981
ST10	Alpine white	1 pc	B 5858 0971
ST20	Stainless steel look	1 pc	B 5858 0982
ST20	Alpine white	1 pc	B 5858 0972

SHEV control panel EMB7300

Product characteristics



Product characteristics

- Smoke and heat exhaust ventilation control panel with compact design for stairwells, for control of electromechanical SHEV and ventilation drives with 24 V DC operating voltage
- Control device according to prEN 12101-9 / ISO 21927-9
- Power supply according to EN 12101-10
- Output voltage with low residual ripple (< 2 Vpp), compatible with all standard drives
- 1 SHEV group with 1 monitored ventilation line (also available with 2 ventilation lines as option)
- Removable terminals for convenient connection of detector lines
- Connection of electric motors, pressurised-gas generators and hold-open magnets
- 2 detector line inputs with line monitoring for connection of
 - manual push-button fire alarm switches (HSE push-buttons)
 - automatic smoke/heat detectors
- 1 ventilation push-button input with "OPEN-STOP-CLOSE" function (2 ventilation push-button inputs are also available as option)
- 2 slots for relay cards for forwarding of events (emergency open, interference)
- 1 slot for BUS network cards (KNX)
- Direct connection for wind/rain sensor
- Clearly laid out display and control elements
- Extensive range of settings for basic functions via the free "EMB compact" configuration software
- Further setting options (e.g. maintenance period) with software licence subject to a charge (see page 266)
- Housing cover (optional) with integrated HSE and ventilation push-button (2.5 A / 5 A)
- Housing frame for flush-mounted installation (2.5 A / 5 A)
- Cable infeed from above, from below or from behind
- Prepared for the connection of rechargeable batteries for emergency power supply over 72 hours (see page 263)
- VdS approval number G 514001

SHEV control panel EMB7300

Performance scope of software



Performance scope of software

Functions	Standard	Licence
Changeover of ventilation from deadman mode to latching (OPEN, CLOSE or OPEN and CLOSE)	■	■
Drive line interference can be configured as alarm	■	■
Deactivate emergency open in the event of interference (smoke detector and manual call point)	■	■
Adjust the switching threshold of a wind sensor	■	■
Limit drive runtime / travel for ventilation operation	■	■
Activate and configure time-controlled automatic closing	-	■
Activate closing operation in the event of mains failure	■	■
Set acoustic and visual warning signal (requires additional hardware)	-	■
Display, save and print out system status	■	■
Firmware update	■	■
Set EMERGENCY CLOSE push-button from latching to deadman operation	■	■
Configure next service/maintenance time (password-protected)	-	■
Configure switch-on delay of a wind sensor	-	■
Configure switch-off delay of a wind sensor	-	■
Deactivate subsequent cycling of the drives	-	■
Activate / deactivate manual fire alarm (HSE)	-	■
Activate / deactivate smoke switch	-	■
Smoke switch input with "FACP" function	-	■
Configure switch-off time of drive line	-	■
Activate / deactivate EMERGENCY CLOSE function with active smoke switch	-	■
Changeover drive running direction: in the event of alarm from opening to closing	-	■
Configure function of optional REL 65 relay cards	-	■
Alarm triggered based on line in the event of drive malfunction (with version with 2 drive lines)	-	■
Switching state reinstated prior to weather control	-	■
Integration into digital networks (KNX) (requires additional plug-in cards)	-	■
Ventilation control unit function	-	■
Setting of operating mode (magnetic lock / standard drive / pressurised gas)	-	■
SHEV deadman operation	-	■
Ventilation push-button setting, parallel operation	-	■
Setting the maintenance timer	-	■
OPEN in the event of mains failure	-	■
Press reset button to activate EMERGENCY CLOSE	-	■
Configure content of group fault	-	■

SHEV control panel EMB7300

Application example of a complete system

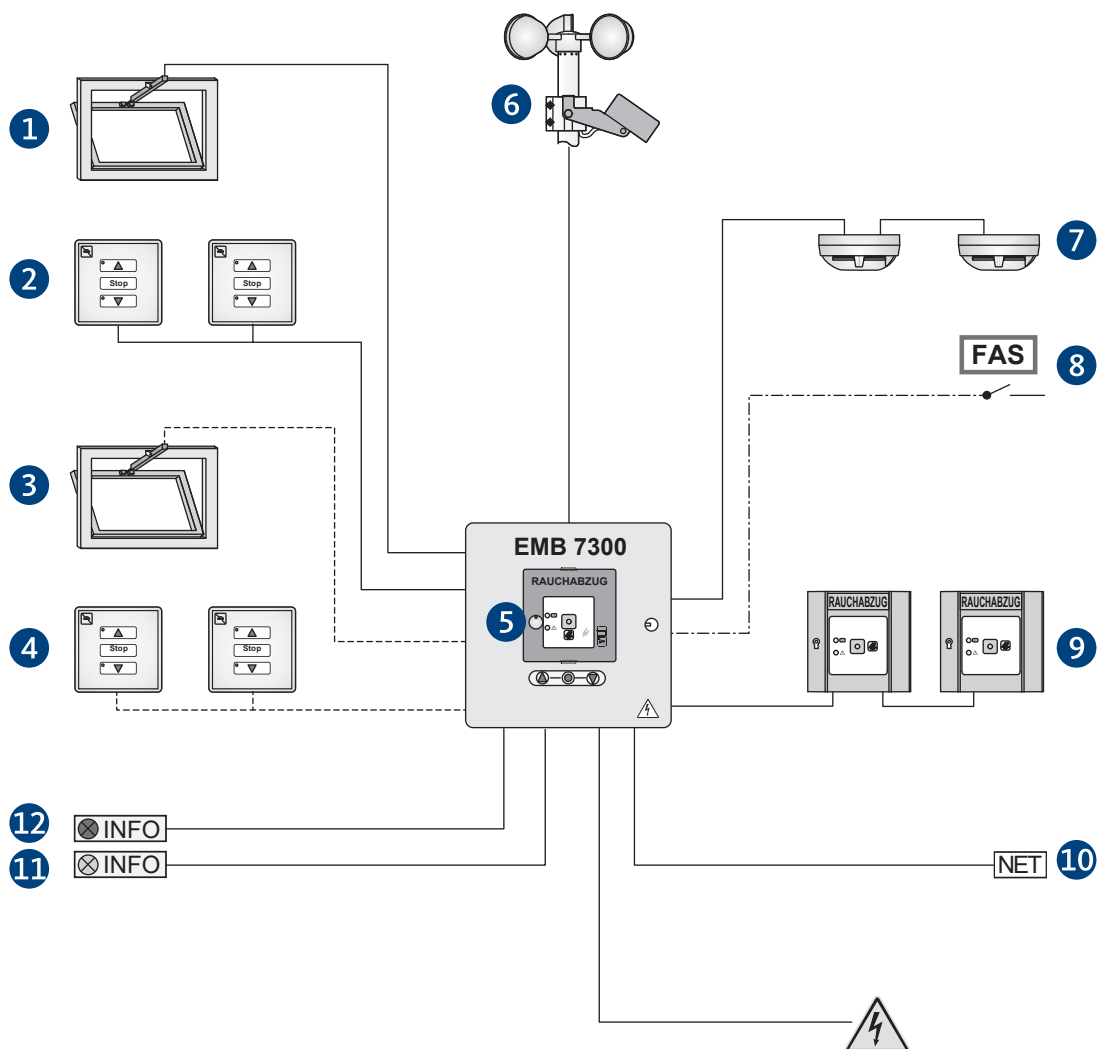

Legend

Legend	
1	Drive line 1 24 V DC for smoke and heat extraction and ventilation
2	Ventilation line 1 max. 10 push-buttons
3	Drive line 2 (only with EMB7300 5 A 0102, 10 A 0102, 20 A 0102)
4	Ventilation line 2 max. 10 push-buttons (only with EMB7300 5 A 0102, 10 A 0102, 20 A 0102)
5	Control unit housing with or without integrated SHEV and ventilation push-button
6	Wind and rain sensor (not active in the event of an alarm and during operation with rechargeable battery)
7	Smoke switch max. 10 pcs
8	Trigger signal from external fire alarm system (alternative connection)
9	Manual call point (HSE push-button) max. 10 pcs
10	Integration into network (additional module required)
11	External signal forwarding 1 (REL 65 plug-in card required)
12	External signal forwarding 2 (REL 65 plug-in card required)
-----	only possible with EMB7300 5 A 0102, 10 A 0102, 20 A 0102

SHEV control panel EMB7300

Technical data



Technical data

Specification	EMB7300 2.5 A 0101	EMB7300 5 A 0101	EMB7300 5 A 0102
Operating voltage	230 V AC (195 – 253 V AC, 50/60 Hz)		
Max. power consumption	115 W	460 W	460 W
Output voltage	24 V DC (20 –28 V DC / 2 Vpp)	24 V DC (20 –28 V DC / 0.5 Vpp)	
Output current	2.5 A	5.0 A	5.0 A
Ambient temperature	-5 °C to +40 °C	-5 °C up to+40 °C	-5 °C to +40 °C
Protection code	IP30	IP30	IP30
Surface-mounted housing	Sheet steel, RAL 7035 (light grey)	Sheet steel, RAL 7035 (light grey)	Sheet steel, RAL 7035 (light grey)
Dimensions (W x H x D)	225 x 285 x 122 mm	225 x 285 x 122 mm	225 x 285 x 122 mm
Connection terminals	1.5 mm ² / drives: 4 mm ² (fixed)	1.5 mm ² / drives: 6 mm ² (fixed)	
Cable infeed	top / bottom / rear	top / bottom / rear	top / bottom / rear
VdS approval no.	G 514001 [1]	G 514001 [1]	G 514001
Motherboard	1 SHEV group 1 ventilation group	1 SHEV group 1 ventilation group	1 SHEV group 2 ventilation groups
Prepared for 2 maintenance-free emergency batteries	2 x 12 V / 2.3 Ah	2 x 12 V / 2.3 Ah	2 x 12 V / 2.3 Ah

[1] Version without push-button or with orange HSE push-button

Technical data

Specification	EMB7300 10 A 0101	EMB7300 10 A 0102	EMB7300 10 A 0204	EMB7300 20 A 0102	EMB7300 20 A 0204
Operating voltage	230 V AC (195 – 253 V AC, 50/60 Hz)				
Max. power consumption	506 W	506 W	506 W	805 W	805 W
Output voltage	24 V DC (20 –28 V DC / 0.5 Vpp)				
Output current	10.0 A	10.0 A	10.0 A	20.0 A	20.0 A
Ambient temperature	-5 °C to +40 °C	-5 °C up to+40 °C	-5 °C up to+40 °C	-5 °C up to+40 °C	-5 °C to +40 °C
Protection code	IP40 / IP54 [2]	IP40 / IP54 [2]	IP40 / IP54 [2]	IP40 / IP54 [2]	IP40 / IP54 [2]
Surface-mounted housing	Sheet steel, RAL 7035 (light grey)				
Dimensions (W x H x D)	400 x 300 x 150 mm	400 x 300 x 150 mm	400 x 500 x 200 mm	400 x 400 x 200 mm	400 x 500 x 200 mm
Connection terminals	1.5 mm ² / drives: 6 mm ² (fixed)				
Cable infeed	at top / at bottom	at top / at bottom	at top / at bottom	at top / at bottom	at top / at bottom
VdS approval no.	G 514001	G 514001	G 514001	G 514001	G 514001
Motherboard	1 SHEV group 1 ventilation group	1 SHEV group 2 ventilation groups	2 SHEV groups 4 ventilation groups	1 SHEV group 2 ventilation groups	2 SHEV groups 4 ventilation groups
Prepared for 2 maintenance-free emergency batteries	2 x 12 V / 7 Ah	2 x 12 V / 7 Ah	2 x 12 V / 7 Ah	2 x 12 V / 7 Ah	2 x 12 V / 12 Ah

[2] IP 54 with optional wall fixing lugs/gaskets

SHEV control panel EMB7300

Order information – version EMB7300 2.5 A



Order information

Specification	PU	Order number
EMB7300 2.5 A 0101	1 pc	683020-0101
Version with HSE and ventilation push-button on housing cover		
EMB7300 2.5 A 0101-T HSE red (sim. to RAL 3000)	1 pc	683021-0101
EMB7300 2.5 A 0101-T HSE yellow (sim. to RAL 1018)	1 pc	683022-0101
EMB7300 2.5 A 0101-T HSE grey (sim. to RAL 7035)	1 pc	683023-0101
EMB7300 2.5 A 0101-T HSE blue (sim. to RAL 5009)	1 pc	683024-0101
EMB7300 2.5 A 0101-T HSE orange (sim. to RAL 2011) VdS approval no.: G 514001	1 pc	683025-0101

1 SHEV group / 1 ventilation group

SHEV control panel EMB7300

Order information – version EMB7300 5 A



Order information

Specification	PU	Order number
EMB7300 5 A 0101	1 pc	683050-0101
Version with HSE and ventilation push-button on housing cover		
EMB7300 5 A 0101-T HSE red (sim. to RAL 3000)	1 pc	683051-0101
EMB7300 5 A 0101-T HSE yellow (sim. to RAL 1018)	1 pc	683052-0101
EMB7300 5 A 0101-T HSE grey (sim. to RAL 7035)	1 pc	683053-0101
EMB7300 5 A 0101-T HSE blue (sim. to RAL 5009)	1 pc	683054-0101
EMB7300 5 A 0101-T HSE orange (sim. to RAL 2011) VdS approval no.: G 514001	1 pc	683055-0101

1 SHEV group / 1 ventilation group



Order information

Specification	PU	Order number
EMB7300 5 A 0102	1 pc	683050-0102

1 SHEV group / 2 ventilation groups

SHEV control panel EMB7300

Order information – version EMB7300 2.5 A | 5 A – accessories



Flush-mounted housing EMB7300 2.5 A / 5 A

- For flush-mounted installation of the 2.5 A and 5 A SHEV compact control units EMB7300 in 225 x 285 x 122 mm surface-mounted housing.

Flush-mounted housing

- Dimensions (W x H x D): 254 x 314 x 96 mm

Plaster frame

- Dimensions (W x H x D): 282 x 342 x 48 mm
- PE connection line: 160 mm with flat connector 6.3 mm

Styrofoam board

- For protection of the flush-mounted housing during plastering work
- Dimensions (W x H x D): 240 x 302 x 93 mm

Material / colour	PU	Order number	
Sheet steel / RAL 7035 (light grey)	1 pc	683111	
Contents:			
1 x flush-mounted housing with 4 x spacer sleeve and M5 nuts, 4 x stainless steel fixing bracket 13 x 13 x 1 mm, 8 x sheet-metal screw ST3 5x6.5			
1 x plaster frame with 4 x M3x6 lens screw, 4 x washer A4			
1 x styrofoam board			

Battery holder set

- Fastening of 12 V / 2.3 Ah emergency batteries in housing of EMB7300 2.5 A and 5A compact control units

Material / colour	PU	Order number	
Sheet steel / RAL 7035 (light grey)	1 pc	683250	

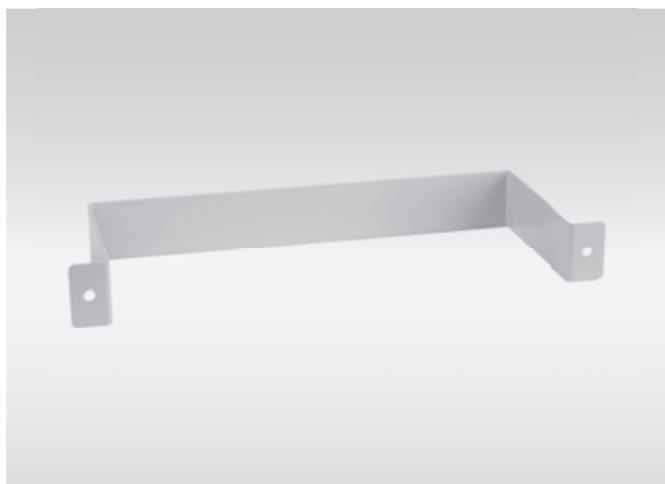

SHEV control panel EMB7300

Order information – version EMB7300 10 A



Order information

Specification	PU	Order number
EMB7300 10 A 0101	1 pc	683010-0101

1 SHEV group / 1 ventilation group



Order information

Specification	PU	Order number
EMB7300 10 A 0102	1 pc	683010-0102

1 SHEV group / 2 ventilation groups



Order information

Specification	PU	Order number
EMB7300 10 A 0204	1 pc	683010-0204

2 SHEV groups / 4 ventilation groups

SHEV control panel EMB7300

Order information – version EMB7300 20 A



Order information

Specification	PU	Order number
EMB7300 20 A 0102	1 pc	683220-0102

1 SHEV group / 2 ventilation groups



Order information

Specification	PU	Order number
EMB7300 20 A 0204	1 pc	683220-0204

2 SHEV groups / 4 ventilation groups

SHEV control panel EMB7300

Order information – Accessories

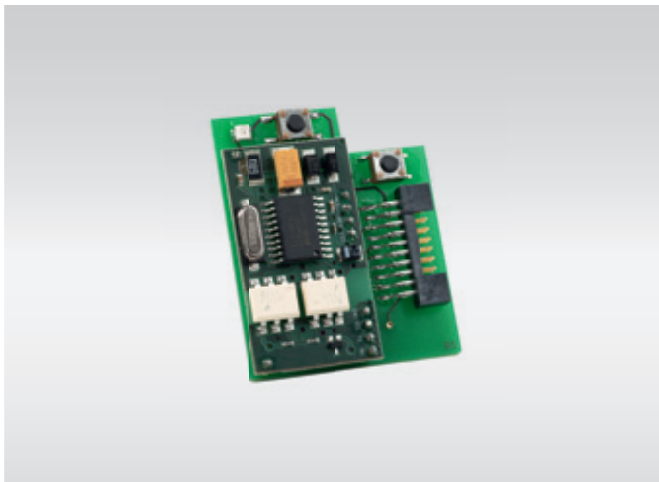

BI-K – KNX Interface LZ1 / LZ6 / EMB7300

- Plug-in card for communication between control units LZ1, LZ6 and EMB7300 on the KNX-BUS system

Product characteristics

- Control unit data (e.g. drive position) is transmitted on the KNX-BUS
- The control units receive direct commands from the KNX-BUS (e.g. position data, weather data)
- The licensed version of the EMB compact configurator is required for commissioning

Technical data	
Operating voltage	24 V DC
Ambient temperature	-5 °C to +40 °C
Relative air humidity (not condensate)	5 % up to 90 %
Data points	up to 16 pcs per motor line
BUS power	9 mA
Dimensions (W x H)	51 x 42 mm
Connection terminals	2 x 2 x 0.8 mm (KNX-BUS terminal)

	PU	Order number	
	1 pc	683999	

Wall fixing lugs IP54

- For achievement of IP 54 protection code

	PU	Order number	
	4 pc	500001	

SHEV control panel EMB7300

Order information – Accessories



REL 65 plug-in card

- Plug-in card for EMB7300 SHEV compact control units with relay for forwarding of "emergency open" or "fault" signals
- Plug connector for attaching REL65 plug-in card to the mother board

Technical data	
Nominal voltage	24 V DC
Ambient temperature	-5 °C to +40 °C
Dimensions (W x H x D)	20 x 40 x 13 mm
Connection terminals	3 x 1.5 mm ² (fixed)
Potential-free contact	1 x Um, max. 48 V / 1 A

Specification	PU	Order number
Dispatch for self-installation by customer	1 pc	650200
Installed at the factory and pre-wired ready for operation	1 pc	650200-9



Plug-in card 7xPSB

- Plug-in card for EMB7300 SHEV compact control units for picking up 24 V DC control voltage for external consumers*
- Plug connector for attaching 7xPSB plug-in card to the mother board

Technical data	
Nominal voltage	24 V DC
Ambient temperature	-5 °C to +40 °C
Output current	0.5 A
Dimensions (W x H x D)	20 x 32 x 13 mm
Connection terminals	4 x 1.5 mm ² (fixed)
Voltage tap	2 terminals 24 V DC supplied by emergency power 2 terminals 24 V DC mains voltage

Specification	PU	Order number
Dispatch for self-installation by customer	1 pc	683256
Installed at the factory and pre-wired ready for operation	1 pc	683256-9

*PLEASE NOTE: the power consumption for external consumers must be taken into account when sizing the total power demand.

SHEV control panel EMB7300

Order information – Accessories



USB cable

- For connecting a PC to the EMB7300 compact control unit for programming of basic or special functions
- "EMB compact" configuration software required

Technical data	
USB standard	USB2
Cable length	3 m

	PU	Order number	
	1 pc	683253	



Backup batteries

- For maintaining SHEV control units in standby mode for a period of 72 hours
- Maintenance-free operation, extended service life, very good charging efficiency and cyclic stability
- 2 batteries are always required per control unit

Technical data	
Product	Lead battery
Voltage	12 V DC
Lifetime*	4 years (under normal conditions)
Connection type	1.2 – 12 Ah: Flat connector 4.8 mm 17 – 38 Ah: Screw connection M5
Cylinder body	PVC, impact-resistant and shatterproof

Capacity	PU	Order number	
2.2/2.3 Ah, 12 V	1 pc	541000	
7 Ah, 12 V	1 pc	542000	
12 Ah, 12 V	1 pc	542200	

*Disposal in accordance with local and national laws and guidelines (WEEE)

SHEV control panel EMB7300

Order information – Accessories



Push-button fire alarm switch Wireless HSE

Application

- Manual call point with displays for manual activation of emergency-open function and the close function of a SHEV group via wireless communication with the EMB7300 SHEV control unit
- The licensed version of the EMB compact configurator is required for commissioning

Product characteristics

- Lockable, glazed door (incl. key)
- Wireless push-button
- Incl. 3.6 V lithium battery

Technical data	
Operating voltage	3.6 V DC
Ambient temperature	-5 °C to +40 °C
Cylinder body	Surface-mounted, PVC (ABS)
Dimensions (W x H x D)	130 x 130 x 32 mm
Protection code	IP30
Displays	EMERGENCY OPEN, operation, fault
Operating elements	EMERGENCY OPEN push-button, CLOSE push-button

Specification	PU	Order number	
orange (similar to RAL 2011)	1 pc	528340	
red (similar to RAL 3000)	1 pc	528341	
yellow (similar to RAL 1018)	1 pc	528342	
blue (similar to RAL 5015)	1 pc	528343	
grey (similar to RAL 7035)	1 pc	528344	

Spare lithium battery 3.6 V

	PU	Order number	
	1 pc	545050	

SHEV control panel EMB7300

Order information – Accessories



Receiver plug-in card for wireless SHEV

- For bi-directional wireless communication between the EMB7300 SHEV control unit and up to 10 wireless push-button fire alarm switches
- The licensed version of the EMB compact configurator is required for commissioning

Technical data	
Nominal voltage	24 V DC
Ambient temperature	-5 °C to +40 °C
Relative air humidity (not condensate)	5 % up to 90 %
Dimensions (W x H)	51 x 42 mm
Connections	SMA aerial connection

	PU	Order number	
	1 pc	528738	



Wireless aerial

- For bi-directional wireless communication between the EMB7300 SHEV control unit and up to 10 wireless push-button fire alarm switches
- The licensed version of the EMB compact configurator is required for commissioning

Technical data	
Ambient temperature	-5 °C to +40 °C
Relative air humidity (not condensate)	5 % up to 90 %
Dimensions (W x H x D)	34 x 265 x 82 mm
Connections	SMA aerial connection

	PU	Order number	
	1 pc	528737	

SHEV control panel EMB7300

Order information – Accessories



Configuration software

- For extended scope of functions
- System prerequisites: Microsoft® Windows 7 or Microsoft® Windows 10 64 Bit

Specification	PU	Order number	
Initial licence (3 years)	1 pc	683260	
Subsequent licence (3 years)	1 pc	683261	
Configuration of customer-specific functions at the factory	1 pc	683262	

SHEV control panel EMB7300

Order information – Accessories



Key 1D9

- Replacement key for EMB7300 control unit housing
- For lock 1D9 with straight deadbolt

	PU	Order number	
	1 pc	260010	



Lock 1D9

- Lock with security cylinder, straight deadbolt and spring
- For EMB7300 control unit housing
- Incl. two keys

	PU	Order number	
	1 pc	260008	

SHEV control panel EMB8000+

Product characteristics



Product characteristics

- Modular control unit featuring digital BUS technology and power supply for activation of 24 V DC electric drives for SHEV and controlled natural ventilation
- Control device according to prEN 12101-9 / ISO 21927-9
- Power supply according to EN 12101-10
- Output voltage with low residual ripple (< 2 Vpp), compatible with all standard drives
- Straightforward space-saving installation of modules on top-hat rail with many varied combination options
- Straightforward configuration of SHEV and ventilation groups by arranging the modules side-by-side
- Control and sensor modules with 3 line-monitored prioritisable detector line inputs for connection of
 - manual push-button fire alarm switches (HSE push-buttons)
 - automatic smoke/heat detectors
 - control signals of fire alarm systems
- Drive module with line-monitored outputs for connection of drives with current consumptions up to 20 A
- Relay module for evaluation and forwarding of events (EMERGENCY OPEN, fault, checkback signals)
- Weather module for connection of wind speed, wind direction and rain sensors
- BUS network modules (CAN, KNX)
- All ventilation push-button inputs equipped with OPEN-STOP-CLOSE function and several switching priorities
- Clearly laid out display and control elements
- Comprehensive range of settings are available for basic functions with the free EMB8000 configuration software
- Many special functions can be programmed using licensed software subject to a fee (see page 291)
- Sheet steel housing, IP 40 / IP 54 protection with optional wall mounting lugs and gaskets
- Cable infeed from above
- Prepared for the connection of rechargeable batteries for emergency power supply over 72 hours (see page 289)
- VdS approval number G 512005
- In the as-delivered state, SHEV and ventilation groups can also be configured to be interconnected without software by arranging specific modules in sequence
- System components for individual expansion consisting of functional basic control units each with a SHEV and ventilation group, and a wide range of modules and built-in units which can be ordered pre-installed and operational ex works or for self-installation by the customer
- A wide range of software options is available to facilitate adjustment in individual cases

SHEV control panel EMB8000+

Performance scope of software



Performance scope of software

Functions	Standard	Licence
Load and save configuration, and save it under a different name	■	■
Display, save and print out system status	■	■
Call up switching thresholds and switch-on/off delay of the wind sensor	■	■
Generate PDF of the configuration	■	■
Load and save system configuration / settings	■	■
Read RealTime LOG files	■	■
Set password for control units	-	■
Edit RealTime LOG files	-	■
Firmware update	-	■
Configure switching thresholds and switch-on/off delay of the wind sensor	-	■
Configure switching thresholds of the wind direction transducer	-	■
Synchronise / update system time of the system	-	■
Battery monitoring: behaviour and fault message (active, window OPEN / CLOSE)	-	■
Set battery type and charging characteristics (temperature-dependent / constant)	-	■
Mains failure: behaviour and fault message (economy mode, window CLOSE, ventilation operation)	-	■
Ventilation push-button in deadman mode or in latching (OPEN, CLOSE or OPEN and CLOSE)	-	■
Ventilation push-button with single push-button operation (OPEN/STOP or CLOSE/STOP with one push-button)	-	■
Automatic incremental operation in OPEN direction (activate Automatic / set time)	-	■
Activate reset of the smoke detector lines with EMERGENCY CLOSE	-	■
Detector line input with "FAS" function	-	■
Deactivate EMERGENCY OPEN in the event of interference in the detector lines (smoke detector and manual call point)	-	■
Deactivate fault evaluation of detector lines (smoke detector and manual call point)	-	■
Configure functions of the PM, CM and SM detector relay	-	■
Configure next service/maintenance time and behaviour of system	-	■
Configure drive lines for motors, hold-open magnets or pressurised-gas generators	-	■
Deactivate subsequent cycling of the drives	-	■
Configure switch-off time of drive line	-	■
Activate and configure time-controlled automatic closing	-	■
Activate closing operation of drives in the event of mains failure	-	■
Limit drive runtime / travel for ventilation operation	-	■
Configure EMERGENCY OPEN in the event of a fault in the drive lines	-	■
Changeover drive running direction: in the event of alarm from opening to closing	-	■
Configure signalling contact input of drive lines (checkback signal / inhibit input)	-	■
Configure opening / closing of drive lines depending on wind direction	-	■
Reinstatement of switching states prior to weather-dependent activation	-	■
Set EMERGENCY CLOSE push-button from latching to deadman operation	-	■
Configure relay functions of RM6	-	■
Assignment of detector and drive lines to fire, ventilation and weather sections	-	■
Interconnection of several control units to form a network with higher-level functions	-	■
Integration into digital networks, e.g. CAN, KNX (requires additional modules)	-	■

SHEV control panel EMB8000+

Application example of a complete system

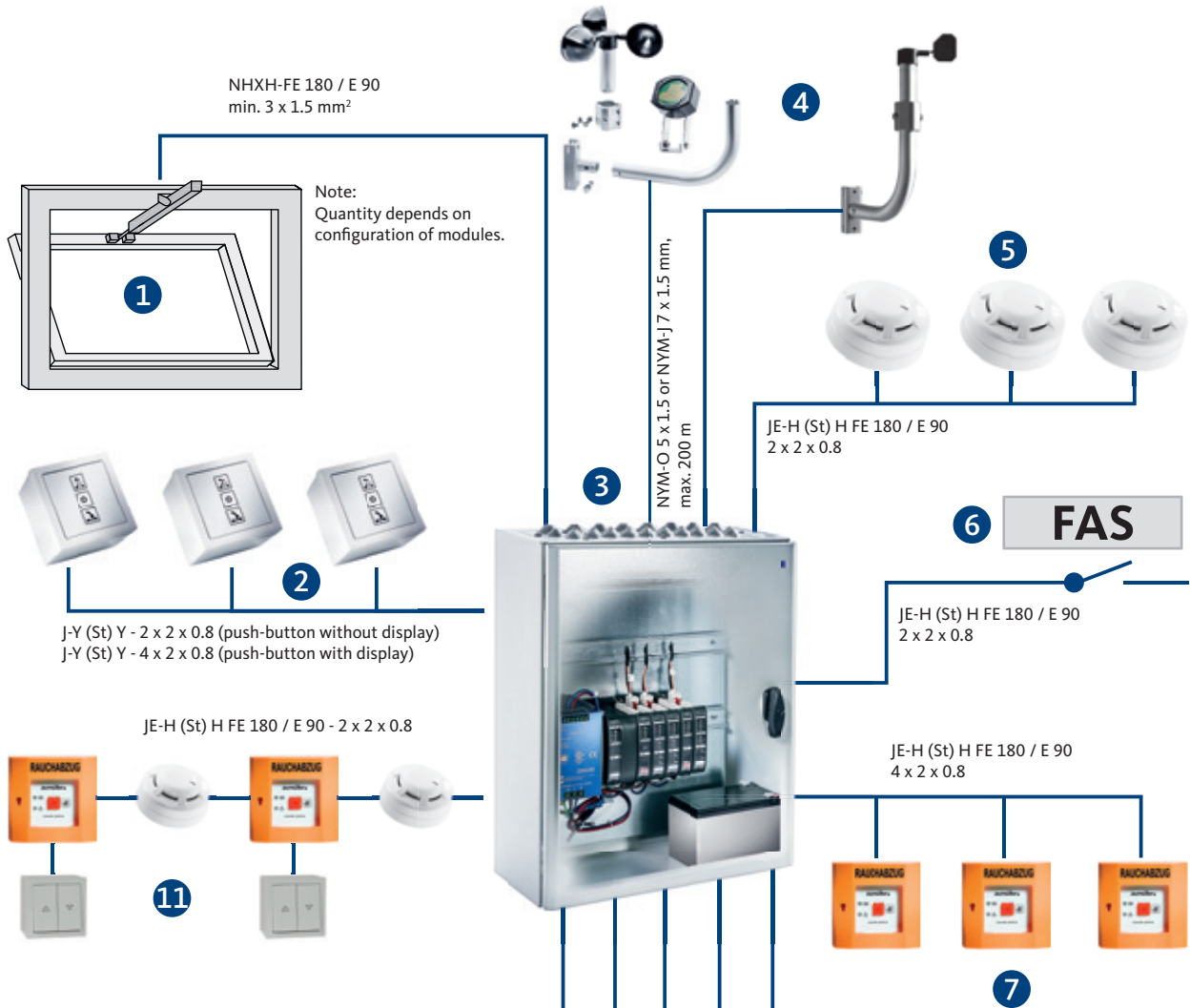

Legend	
1	Drive line 24 V DC for smoke and heat extraction and ventilation
2	Ventilation line max. 10 push-buttons
3	Control unit housing
4	Wind and rain sensor (not active in the event of an alarm and during operation with rechargeable battery)
5	Smoke detector max. 10 pcs per SM
6	Trigger signal from external fire alarm system to smoke switch
7	Manual call point (HSE push-button) max. 10 pcs per SM
8	Temperature controller
9	External signal forwarding
10	Integration into network (additional module required)
11	BUS-HSE max. 30 participants

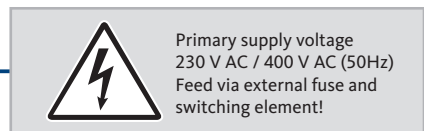
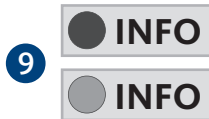

SHEV control panel EMB8000+



Basic versions can be removed

Planning, expansion limitation, configuration, key data of installation modules



Key data of EMB8000+ installation modules												
Technical features					Cable pinout of module inputs / outputs							
Modules	Module width [mm]	Module units [ME]	Own current consumption [mA]	Cable entries with full assignment [Qty.]	Smoke switch, FACP	Manual call point	Supply cable, drives	Ventilation push-button with display	Ventilation push-button without display, other inputs	Potential-free contact, checkback signal of drives	Wind / Rain / Wind direction	Mains supply line
PM	46	2	16.0	1	-	-	-	-	-	-	-	1
PME	46	2	0.0	0	-	-	-	-	-	-	-	-
CM+	23	1	34.1	5	2	1	-	-	1	1	-	-
SM	23	1	12.6	5	2	1	-	-	1	1	-	-
DM	23	1	5.3	3	-	-	1	1	-	1	-	-
230 V DM	23	1	7.0	3	-	-	1	1	-	1	-	-
DMX	46	2	5.3	3	-	-	1	1	-	1	-	-
IDM	23	1	6.0	5	-	-	1	1	-	1	-	-
RM6	23	1	5.3	1	-	-	-	-	-	1 - 6	-	-
IM-K	23	1	6.0	10	-	-	-	-	-	-	-	-
WM	23	1	13.0	4	-	-	-	-	2	1	1	-
Recommended number of wires (without protective earth conductor)				-	4	8	4	8	4	4	7	3

Internal current consumption of detectors supplied by emergency power		
Manual call point main control unit	HSE	1.2 mA
Manual call point, secondary control point	HSE-N	0.0 mA
Optical smoke detector	ORM	0.1 mA
Wind direction sensor	WRG	7.1 mA
BUS push-button fire alarm switch	BUS-HSE	2.8 mA
BUS smoke switch	BUS-RM	1.0 mA

max. internal current consumption per control unit					
SNT / battery	7 Ah	12 Ah	17 Ah	24 Ah	38 Ah
10 A	-	120 mA	140 mA	240 mA	350 mA
24 A	-	70 mA	120 mA	200 mA	300 mA
48 A	-	-	80 mA	170 mA	300 mA
72 A	-	-	-	100 mA	300 mA

Dimensions of connection terminals (straight-through terminals with spring-loaded connection)				
Terminal size	6 mm ²	10 mm ²	16 mm ²	End support
Cable cross-section (fixed)	0.13 – 6 mm ²	2.5 – 10 mm ²	4 – 16 mm ²	-
Overall width of individual terminal (straight-through terminal)	6 mm	10 mm	12 mm	8 mm
Overall width of terminal set with 5 terminals and end support	38 mm	58 mm	-	-

Line calculation			
$A = 2 * L * I / (56 * \Delta U)$			
A	Cross-section of wires [mm ²]	I	Current in connected drives [A]
L	Length of line [m]	ΔU	Voltage drop on the line [V] = max. 2 V permitted

SHEV control panel EMB8000+

Technical data | control panels



Technical data

Specification	EMB8000+ 5 A		EMB8000+ 10 A		EMB8000+ 24 A	
Operating voltage	230 V AC (195 – 253 V AC, 50/60 Hz)					
Max. power consumption	322 W		506 W		805 W	
Output voltage	24 V DC (20 – 28 V DC / 0.5 Vpp)					
Output current	5.0 A		10.0 A		24.0 A	
Connections and functions	depending on expansion*					
Protection code	IP40 / IP54 [1]		IP40 / IP54 [1]		IP40 / IP54 [1]	
Cylinder body	Surface-mounted, sheet-steel, RAL 7035 (light grey)					
Dimensions (W x H x D) [mm]	400 x 500 x 200	600 x 600 x 250	400 x 500 x 200	600 x 600 x 250	600 x 600 x 250	600 x 800 x 250
Delivery condition						
SHEV groups	1	1	1	1	1	1
Ventilation groups	1	1	1	1	1	1
Prepared for batteries (capacity in accordance with expansion)	max. 2 x 12 V / 12 Ah	max. 2 x 12 V / 12 Ah	max. 2 x 12 V / 12 Ah	max. 2 x 12 V / 38 Ah	max. 2 x 12 V / 38 Ah	max. 2 x 12 V / 38 Ah

[1] with optional wall fixing lugs IP54

Technical data

Specification	EMB8000+ 48 A		EMB8000+ 72 A		EMB8000+ 96 A	
Operating voltage	230 V AC (195 – 253 V AC, 50/60 Hz)				400 V AC (50/60 Hz) 3 phase conductors	
Max. power consumption	1610 W		2415 W		3220 W	
Output voltage	24 V DC (20 – 28 V DC / 0.5 Vpp)					
Output current	48.0 A		72.0 A		96.0 A	
Connections and functions	depending on expansion*					
Protection code	IP40 / IP54 [1]		IP40 / IP54 [1]		IP40 / IP54 [1]	
Cylinder body	Surface-mounted, sheet-steel, RAL 7035 (light grey)					
Dimensions (W x H x D) [mm]	600 x 600 x 250	600 x 800 x 250	600 x 800 x 250	800 x 800 x 250	800 x 800 x 250	800 x 1000 x 250
Delivery condition						
SHEV groups	1	1	1	1	2	2
Ventilation groups	1	1	1	1	2	2
Prepared for batteries (capacity in accordance with expansion)	max. 2 x 12 V / 38 Ah	max. 2 x 12 V / 38 Ah	max. 2 x 12 V / 38 Ah	max. 2 x 12 V / 38 Ah	max. 4 x 12 V / 38 Ah	max. 4 x 12 V / 38 Ah

[1] with optional wall fixing lugs IP54

* During expansion, the current consumption of the built-in and peripheral devices, number of expandible module slots and cable entries must be checked independently to ensure it matches the battery capacity and system limits and must be adhered to.

SHEV control panel EMB8000+

Order information – version EMB8000+ 5 A



SHEV modular control unit EMB8000+ 5 A

- For individual expansion*
- Basic equipment mounted and pre-wired at the factory

1 SHEV group / 1 ventilation group

Specification	Module equipment	Free module unit	Free top-hat rail	PU	Order number	
EMB8000+ 5 A 400 x 500 x 200 mm	PM, CM, DM	ME 8	HS 300 mm	1 pc	688305-9501	
	PM, CM, IDM	ME 8	HS 300 mm	1 pc	688305-9503	



SHEV modular control unit EMB8000+ 5 A

- For individual expansion*
- Basic equipment mounted and pre-wired at the factory

1 SHEV group / 1 ventilation group

Specification	Module equipment	Free module unit	Free top-hat rail	PU	Order number	
EMB8000+ 5 A 600 x 600 x 250 mm	PM, CM, DM	ME 19	HS 500 mm	1 pc	688305-9601	
	PM, CM, IDM	ME 19	HS 500 mm	1 pc	688305-9603	

* During expansion, the current consumption of the built-in and peripheral devices, number of expandible module slots and cable entries must be checked independently to ensure it matches the battery capacity and system limits and must be adhered to.

SHEV control panel EMB8000+

Order information – version EMB8000+ 10 A



SHEV modular control unit EMB8000+ 10 A

- For individual expansion*
- Basic equipment mounted and pre-wired at the factory

1 SHEV group / 1 ventilation group

Specification	Module equipment	Free module unit	Free top-hat rail	PU	Order number	
EMB8000+ 10 A 400 x 500 x 200 mm	PM, CM, DM	ME 7	HS 300 mm	1 pc	688310-9501	
	PM, CM, IDM	ME 7	HS 300 mm	1 pc	688310-9503	



SHEV modular control unit EMB8000+ 10 A

- For individual expansion*
- Basic equipment mounted and pre-wired at the factory

1 SHEV group / 1 ventilation group

Specification	Module equipment	Free module unit	Free top-hat rail	PU	Order number	
EMB8000+ 10 A 600 x 600 x 250 mm	PM, CM, DM	ME 19	HS 500 mm	1 pc	688310-9601	
	PM, CM, IDM	ME 19	HS 500 mm	1 pc	688310-9603	

* During expansion, the current consumption of the built-in and peripheral devices, number of expandible module slots and cable entries must be checked independently to ensure it matches the battery capacity and system limits and must be adhered to.

SHEV control panel EMB8000+

Order information – version EMB8000+ 24 A



SHEV modular control unit EMB8000+ 24 A

- For individual expansion*
- Basic equipment mounted and pre-wired at the factory

1 SHEV group / 1 ventilation group

Specification	Module equipment	Free module unit	Free top-hat rail	PU	Order number	
EMB8000+ 24 A 600 x 600 x 250 mm	PM, CM, DM	ME 19	HS 500 mm	1 pc	688324-9501	
	PM, CM, DMX	ME 18	HS 500 mm	1 pc	688324-9502	
	PM, CM, IDM	ME 19	HS 500 mm	1 pc	688324-9503	



SHEV modular control unit EMB8000+ 24 A

- For individual expansion*
- Basic equipment mounted and pre-wired at the factory

1 SHEV group / 1 ventilation group

Specification	Module equipment	Free module unit	Free top-hat rail	PU	Order number	
EMB8000+ 24 A 600 x 800 x 250 mm	PM, CM, DM	ME 26	HS 500 mm	1 pc	688324-9601	
	PM, CM, DMX	ME 25	HS 500 mm	1 pc	688324-9602	
	PM, CM, IDM	ME 26	HS 500 mm	1 pc	688324-9603	

* During expansion, the current consumption of the built-in and peripheral devices, number of expandible module slots and cable entries must be checked independently to ensure it matches the battery capacity and system limits and must be adhered to.

SHEV control panel EMB8000+

Order information – version EMB8000+ 48 A



SHEV modular control unit EMB8000+ 48 A

- For individual expansion*
- Basic equipment mounted and pre-wired at the factory

1 SHEV group / 1 ventilation group

Specification	Module equipment	Free module unit	Free top-hat rail	PU	Order number	
EMB8000+ 48 A 600 x 600 x 250 mm	PM, PME, CM, DM	ME 9	HS 500 mm	1 pc	688348-9501	
	PM, PME, CM, DMX	ME 8	HS 500 mm	1 pc	688348-9502	
	PM, PME, CM, IDM	ME 9	HS 500 mm	1 pc	688348-9503	



SHEV modular control unit EMB8000+ 48 A

- For individual expansion*
- Basic equipment mounted and pre-wired at the factory

1 SHEV group / 1 ventilation group

Specification	Module equipment	Free module unit	Free top-hat rail	PU	Order number	
EMB8000+ 48 A 600 x 800 x 250 mm	PM, PME, CM, DM	ME 17	HS 500 mm	1 pc	688348-9601	
	PM, PME, CM, DMX	ME 16	HS 500 mm	1 pc	688348-9602	
	PM, PME, CM, IDM	ME 17	HS 500 mm	1 pc	688348-9603	

* During expansion, the current consumption of the built-in and peripheral devices, number of expandible module slots and cable entries must be checked independently to ensure it matches the battery capacity and system limits and must be adhered to.

SHEV control panel EMB8000+

Order information – version EMB8000+ 72 A



SHEV modular control unit EMB8000+ 72 A

- For individual expansion*
- Basic equipment mounted and pre-wired at the factory

1 SHEV group / 1 ventilation group

Specification	Module equipment	Free module unit	Free top-hat rail	PU	Order number	
EMB8000+ 72 A 600 x 800 x 250 mm	PM, 2 x PME, CM, DM	ME 15	HS 500 mm	1 pc	688372-9501	
	PM, 2 x PME, CM, DMX	ME 14	HS 500 mm	1 pc	688372-9502	
	PM, 2 x PME, CM, IDM	ME 15	HS 500 mm	1 pc	688372-9503	



SHEV modular control unit EMB8000+ 72 A

- For individual expansion*
- Basic equipment mounted and pre-wired at the factory

1 SHEV group / 1 ventilation group

Specification	Module equipment	Free module unit	Free top-hat rail	PU	Order number	
EMB8000+ 72 A 800 x 800 x 250 mm	PM, 2 x PME, CM, DM	ME 24	HS 700 mm	1 pc	688372-9601	
	PM, 2 x PME, CM, DMX	ME 23	HS 700 mm	1 pc	688372-9602	
	PM, 2 x PME, CM, IDM	ME 24	HS 700 mm	1 pc	688372-9603	

* During expansion, the current consumption of the built-in and peripheral devices, number of expandible module slots and cable entries must be checked independently to ensure it matches the battery capacity and system limits and must be adhered to.

SHEV control panel EMB8000+

Order information – version EMB8000+ 96 A



SHEV modular control unit EMB8000+ 96 A

- For individual expansion*
- Basic equipment mounted and pre-wired at the factory

2 SHEV groups / 2 ventilation groups

Specification	Module equipment	Free module unit	Free top-hat rail	PU	Order number	
EMB8000+ 96 A 800 x 800 x 250 mm	2 x PM, 2 x PME, 2 x CM, 2 x DM	ME 10	HS 700 mm	1 pc	688396-9501	
	2 x PM, 2 x PME, 2 x CM, 2 x DMX	ME 9	HS 700 mm	1 pc	688396-9502	
	2 x PM, 2 x PME, 2 x CM, 2 x IDM	ME 10	HS 700 mm	1 pc	688396-9503	



SHEV modular control unit EMB8000+ 96 A

- For individual expansion*
- Basic equipment mounted and pre-wired at the factory

2 SHEV groups / 2 ventilation groups

Specification	Module equipment	Free module unit	Free top-hat rail	PU	Order number	
EMB8000+ 96 A 800 x 1000 x 250 mm	2 x PM, 2 x PME, 2 x CM, 2 x DM	ME 17	HS 1000 mm	1 pc	688396-9601	
	2 x PM, 2 x PME, 2 x CM, 2 x DMX	ME 16	HS 1000 mm	1 pc	688396-9602	
	2 x PM, 2 x PME, 2 x CM, 2 x IDM	ME 17	HS 1000 mm	1 pc	688396-9603	

* During expansion, the current consumption of the built-in and peripheral devices, number of expandible module slots and cable entries must be checked independently to ensure it matches the battery capacity and system limits and must be adhered to.

SHEV control panel EMB8000+

Technical data | Modules



Technical data

Specification	Drive module DM	Drive Module Vent 230 V-DM Vent	Drive module DMX	Intelligent Drive Module IDM	Sensor Module SM
Operating voltage	24 V DC	230 V AC	24 V DC	24 V DC	24 V DC
Output voltage	24 V DC (20 – 28 V DC / 0.5 Vpp)	230 V AC	24 V DC (20 – 28 V DC / 0.5 Vpp)	24 V DC (20 – 28 V DC / 0.5 Vpp)	-
Detector line voltage	-	-	-	-	24 V DC
Internal consumption	5.3 mA	7.0 mA	5.3 mA	6.0 mA	12.6 mA
Output current	10 A	5 A	20 A	10 A	-
Housing, ABS, black Dimensions (W x H x D)	100 x 120 x 22.5 mm	100 x 120 x 22.5 mm	100 x 120 x 45 mm	100 x 120 x 22.5 mm	100 x 120 x 22.5 mm
Module units	1 ME	1 ME	2 ME	1 ME	1 ME
Inputs	Ventilation push-button (max. 10 pcs) Checkback signal contact OPEN/CLOSE			Ventilation push-button (max. 10 pcs) Checkback signal contact OPEN/CLOSE 0 – 10 V analogue input	3 detector lines (max. 10 detectors/line) Ventilation push-button (max. 10 pcs)
Outputs	Drive line (pressurised gas generators/hold-open magnets)	Drive line	Drive line (pressurised gas generators/hold-open magnets)	Drive line	1 detector contact (1 x Um, 42 V / 0.5 A)
Displays	Operation, fault, EMERGENCY OPEN, OPEN / CLOSE running direction				Operation, fault, EMERGENCY OPEN
Operating elements	Front push-button: OPEN / CLOSE				Front push-button: Reset
Connections	Plug terminals 1 mm ² rigid Drives: 2.5 mm ² Flat connector 6.3 mm: power supply Socket and plug with cable for internal BUS	Plug terminals 1 mm ² rigid Drives: 2.5 mm ² Socket and plug with cable for internal BUS	Plug terminals 1 mm ² rigid Flat connector 6.3 mm: drives and power supply Socket and plug with cable for internal BUS	Plug terminals 1 mm ² rigid Drives: 2.5 mm ² Flat connector 6.3 mm: power supply Socket and plug with cable for internal BUS 0–10 V analogue input	Plug terminals 1 mm ² rigid Socket and plug with cable for internal BUS
Installed fuse	-	5AT 5 x 20 mm	-	-	-

SHEV control panel EMB8000+

Technical data | Modules



Technical data

Specification	Relay module RM6	KNX module IM-K	Weather module WM	Control module CM	Power module PM	Power module PME
Operating voltage	24 V DC	24 V DC	24 V DC	24 V DC	24 V DC	24 V DC
Output voltage	-	-	-	-	-	-
Detector line voltage	-	-	24 V DC	24 V DC	-	-
Internal consumption	5.3 mA	6.0 mA	13.0 mA	34.1 mA	16.0 mA	0 mA
BUS power	-	9.0 mA	-	-	-	-
Data points	-	up to 16 lines with up to 16 data points	-	-	-	-
Housing, ABS, black Dimensions (W x H x D)	100 x 120 x 22.5 mm	100 x 120 x 22.5 mm	100 x 120 x 22.5 mm	100 x 120 x 22.5 mm	100 x 120 x 45 mm	100 x 120 x 45 mm
Module units	1 ME	1 ME	1 ME	1 ME	2 ME	2 ME
Inputs	-	6 analogue inputs KNX-side, KNX-BUS terminal	Wind/rain sensor, wind direction sensor, external signals	3 detector lines (max. 10 detectors/line) 1 BUS detector line (max. 30 detectors) 1 Ethernet Port 1 CAN interface Ventilation push- button (max. 10 pcs)	-	-
Outputs	6 potential-free relay contacts (1 x Um, 42 V / 0.5 A)	3 potential-free relay contacts via KNX	1 potential-free contact (1 x Um, 42 V / 0.5 A)	1 alarm contact (1 x Um, 42 V / 0.5 A)	-	-
Displays	Operation, error	Operation, fault, KNX programming LED	Operation, fault, wind, rain	Operation, fault, EMERGENCY OPEN	Operation, fault, status	Operation, status
Operating elements	-	KNX programming push-button	-	Front push-button: Reset	-	-
Connections	Plug terminals 1 mm ² rigid Socket and plug with cable for internal BUS	Plug terminals 1 mm ² rigid Socket and plug with cable for internal BUS	Plug terminals 1.5 mm ² rigid	Plug terminals 1 mm ² rigid Socket and plug with cable for internal BUS	Plug terminals 1 mm ² rigid Socket and plug with cable for internal BUS	Socket and plug with cable for internal BUS

SHEV control panel EMB8000+

Order information – Modules

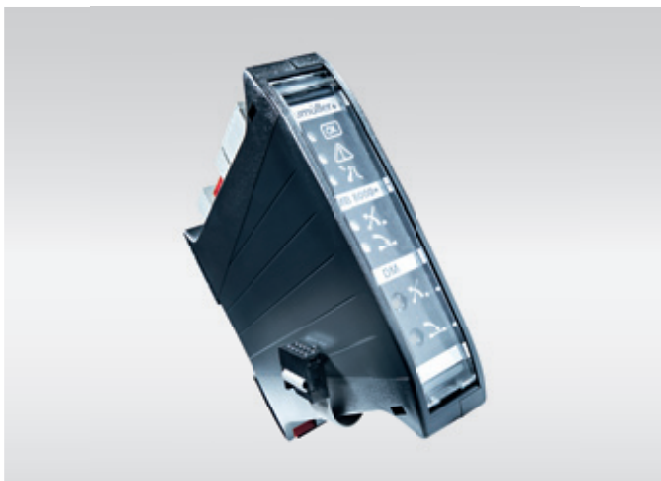

Drive module (DM)

Application

- For activation of drives, pressurised-gas generators or hold-open magnets **up to max. 10 A total current**

Product characteristics

- Monitored drive line
- Fastening on 35 mm top-hat rail
- Programming of functional and performance characteristics that do not conform with the standard via EMB8000+ configuration software

Specification	PU	Order number
Dispatch for self-installation by customer	1 pc	688250
Installed at the factory and pre-wired ready for operation	1 pc	688250-9

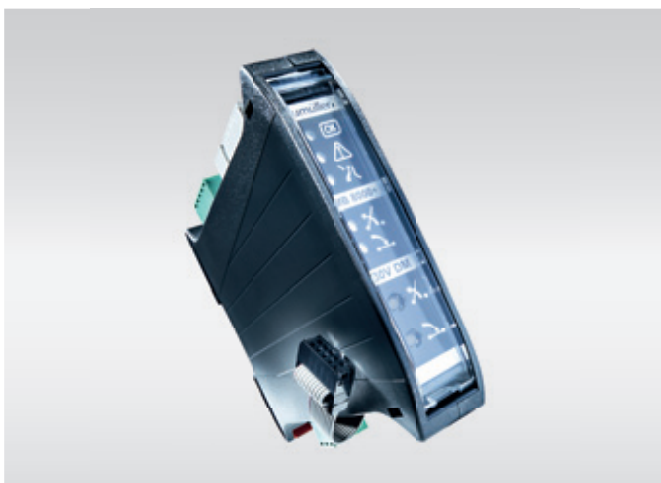

Drive Module Vent (230 V-DM Vent)

Application

- For activation of 230 V AC drives **up to max. 5 A total current**

Product characteristics

- Fastening on 35 mm top-hat rail
- Programming of functional and performance characteristics that do not conform with the standard via EMB8000+ configuration software

Specification	PU	Order number
Dispatch for self-installation by customer	1 pc	688280
Installed at the factory and pre-wired ready for operation	1 pc	688280-9

SHEV control panel EMB8000+

Order information – Modules

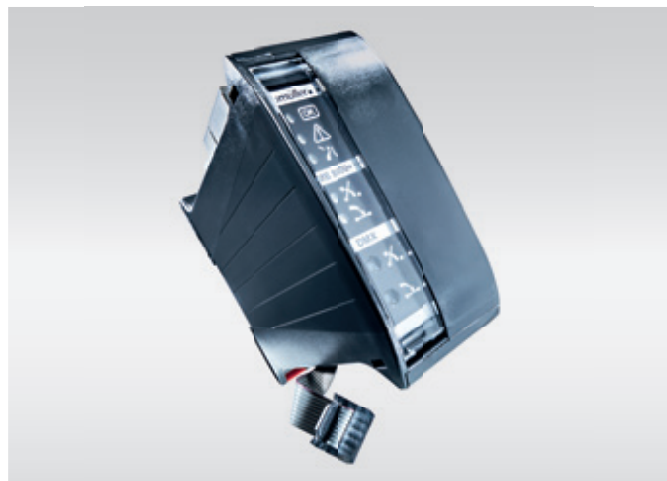

Drive module (DMX)

Application

- For activation of drives, pressurised-gas generators or hold-open magnets **up to max. 20 A total current**

Product characteristics

- Monitored drive line
- Fastening on 35 mm top-hat rail
- Programming of functional and performance characteristics that do not conform with the standard via EMB8000+ configuration software

Specification	PU	Order number
Dispatch for self-installation by customer	1 pc	688255
Installed at the factory and pre-wired ready for operation	1 pc	688255-9

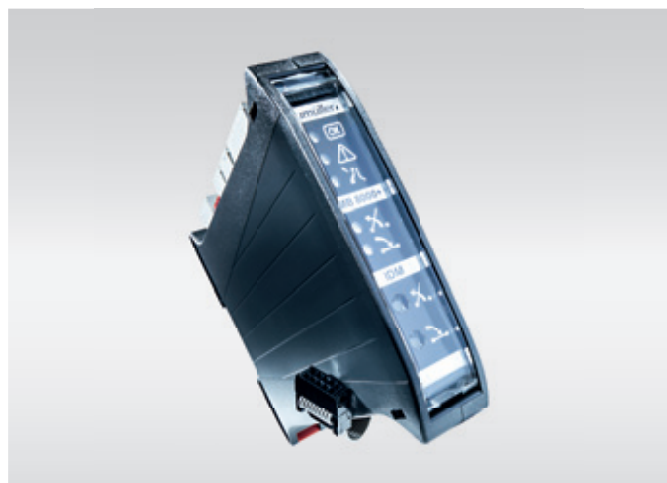

Intelligent Drive Module (IDM)

Application

- For activation of intelligent S12 drives **up to max. 10 A total current**

Product characteristics

- Monitored drive line
- Fastening on 35 mm top-hat rail
- Programming of functional and performance characteristics that do not conform with the standard via EMB8000+ configuration software

Specification	PU	Order number
Dispatch for self-installation by customer	1 pc	688257
Installed at the factory and pre-wired ready for operation	1 pc	688257-9

* Attention: drive output for 6.3 mm flat connector | Included: 3 2.5 mm² cables, 400 mm long, with flat connector | Always also order connection terminals (see page 287)

SHEV control panel EMB8000+

Order information – Modules



Sensor module (SM)

Application

- For connection of automatic and manual detectors

Product characteristics

- Monitored detector lines
- Fastening on 35 mm top-hat rail
- Programming of functional and performance characteristics that do not conform with the standard via EMB8000+ configuration software

Specification	PU	Order number
Dispatch for self-installation by customer	1 pc	688150
Installed at the factory and pre-wired ready for operation	1 pc	688150-9



Relay module (RM6)

Application

- For forwarding of signals via potential-free relay contacts

Product characteristics

- Fastening on 35 mm top-hat rail
- Programming of functional and performance characteristics that do not conform with the standard via EMB8000+ configuration software

Specification	PU	Order number
Dispatch for self-installation by customer	1 pc	688200
Installed at the factory and pre-wired ready for operation	1 pc	688200-9

SHEV control panel EMB8000+

Order information – Modules

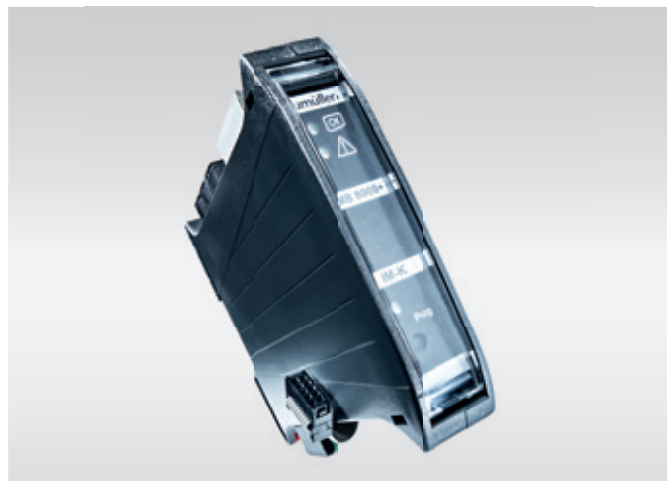

KNX module (IM-K)

Application

- For communication between EMB8000+ control units and the KNX-BUS system

Product characteristics

- Fastening on 35 mm top-hat rail
- Programming of functional and performance characteristics that do not conform with the standard via EMB8000+ configuration software as well as ETS software for KNX programming

Specification	PU	Order number
Dispatch for self-installation by customer	1 pc	688265
Installed at the factory and pre-wired ready for operation	1 pc	688265-9

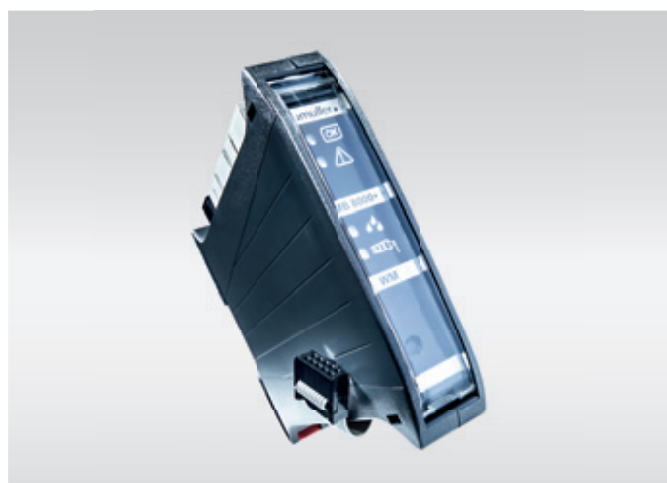

Weather module (WM)

Application

- For connection of sensors for logging of weather data

Product characteristics

- Fastening on 35 mm top-hat rail
- Programming of functional and performance characteristics that do not conform with the standard via EMB8000+ configuration software

Specification	PU	Order number
Dispatch for self-installation by customer	1 pc	688180
Installed at the factory and pre-wired ready for operation	1 pc	688180-9

SHEV control panel EMB8000+

Order information – Modules



Control module (CM)

Application

- For self-installation by the customer in the EMB8000+ SHEV modular control unit for connection of automatic and manual detectors
- Monitors 3 fire alarm lines for triggering and interference
- Processes signals from ventilation push-buttons

Product characteristics

- Fastening on 35 mm top-hat rail
- Programming of functional and performance characteristics that do not conform with the standard via EMB8000+ configuration software
- Belongs to basic equipment features of a control panel and must be connected directly to the Power Module (PM) via BUS cable

	PU	Order number
	1 pc	688120



Power module (PM)

Application

- For self-installation by the customer in the EMB8000+ SHEV modular control unit for monitoring of mains voltage supply
- Monitors the mains voltage supply; checks the battery charging voltage; switches to battery operation in the event of a power outage

Product characteristics

- Fastening on 35 mm top-hat rail
- Programming of functional and performance characteristics that do not conform with the standard via EMB8000+ configuration software
- Equipped with a connection for a sensor for temperature-dependent charging of batteries

	PU	Order number
	1 pc	688050

SHEV control panel EMB8000+

Order information – Modules



Power Module (PME)

Application

- For self-installation by the customer in the EMB8000+ SHEV modular control unit for monitoring of mains voltage supply
- Monitors the mains voltage supply when using more than one switched-mode power supply
- Switches to battery operation in the event of a mains failure

Product characteristics

- Fastening on 35 mm top-hat rail

	PU	Order number
	1 pc	688100

SHEV control panel EMB8000+

Order information – Accessories



Terminals for dispatch

Specification			PU	Order number	
Terminal set	5 x 2.5 mm ²	For self-installation by the customer	1 pc	659941	
Terminal set	5 x 6 mm ²	For self-installation by the customer	1 pc	659942	
Terminal set	5 x 10 mm ²	For self-installation by the customer	1 pc	659943	
Terminal set	5 x 16 mm ²	For self-installation by the customer	1 pc	659944	

Terminals for installation ex works

Specification			PU	Order number	
Single terminal DS	2.5 mm ²	Installed at the factory and pre-wired	1 pc	659945-9	
Single terminal	6 mm ²	Installed at the factory and pre-wired	1 pc	659946-9	
Single terminal	10 mm ²	Installed at the factory and pre-wired	1 pc	659947-9	
Single terminal	16 mm ²	Installed at the factory and pre-wired	1 pc	659948-9	
Terminal set ML	5 x 6 mm ²	Installed at the factory and pre-wired	1 pc	669937-9	
Terminal set ML	5 x 10 mm ²	Installed at the factory and pre-wired	1 pc	669938-9	
Terminal set ML	5 x 16 mm ²	Installed at the factory and pre-wired	1 pc	669939-9	
Terminal set ML 230 V	5 x 4 mm ²	Installed at the factory and pre-wired	1 pc	669949-9	
Terminal set HSE	2.5 mm ²	Installed at the factory and pre-wired	1 pc	669940-9	
Terminal set RM	2.5 mm ²	Installed at the factory and pre-wired	1 pc	669941-9	
Terminal set LT	2.5 mm ²	Installed at the factory and pre-wired	1 pc	669942-9	
Terminal set LT with display	2.5 mm ²	Installed at the factory and pre-wired	1 pc	669943-9	
Terminal set relay	2.5 mm ²	Installed at the factory and pre-wired	1 pc	669944-9	
Terminal set disable contact	2.5 mm ²	Installed at the factory and pre-wired	1 pc	669945-9	
Terminal set BUS-HSE	2.5 mm ²	Installed at the factory and pre-wired	1 pc	669946-9	
Terminal set WM	2.5 mm ²	Installed at the factory and pre-wired	1 pc	669947-9	
Terminal set CAN	2.5 mm ²	Installed at the factory and pre-wired	1 pc	669948-9	

SHEV control panel EMB8000+

Order information – Accessories



Surge arrester type 3

- For central output, 1-phase or 3-phase with additional signalling contact
- For 35 mm top-hat rail
- min. cable cross-section 1.5 mm²
- Installed at the factory and pre-wired ready for operation

Technical data	
Nominal voltage	230 V AC
Specification	Type 3 / Class III
Function display	green / red
Operating temperature	-40 °C to +80 °C
Connection cross-section	max. 4 mm ²
Protection code	IP20

Specification	PU	Order number	
1-phase	1 pc	659977-9	
3-phase	1 pc	659978-9	



Miniature circuit breaker

- For interrupting the circuit in the event of a short-circuit or overload
- Installed at the factory and pre-wired ready for operation

Technical data	
Nominal voltage	230 V AC / 400 AC*
Cylinder body	Insulation material group II, RAL 7035
Operating temperature	-25 °C to +55 °C
Connection cross-section	Flexible with wire end ferrule 0.75 to 25 mm ² *
Protection code	IP20

Specification	PU	Order number	
B 6 A 1-pin (6 A)	1 pc	669970-9	
B 16 A 1-pin (16 A)	1 pc	669971-9	
B 25 A 1-pin (25 A)	1 pc	669972-9	
B 16 A 3-pin (16 A)	1 pc	669973-9	

* depending on version

SHEV control panel EMB8000+

Order information – Accessories



Backup batteries

- For maintaining SHEV control units in standby mode for a period of 72 hours

Product characteristics

- Maintenance-free operation, extended service life, very good charging efficiency and cyclic stability
- 2 batteries are always required per control unit

Technical data	
Product	Lead battery
Voltage	12 V DC
Lifetime*	4 years (under normal conditions)
Connection type	7 – 12 Ah: Flat connector 4.8 mm 17 – 38 Ah: Screw connection M5
Cylinder body	PVC, impact-resistant and shatterproof

Capacity	PU	Order number	
7 Ah, 12 V	1 pc	542000	
12 Ah, 12 V	1 pc	542200	
17 Ah, 12 V	1 pc	543000	
24 Ah, 12 V	1 pc	544000	
38 Ah, 12 V	1 pc	545000	

Wall fixing lugs IP54

- For achievement of IP 54 protection code

	PU	Order number	
	4 pc	500001	

*Disposal in accordance with local and national laws and guidelines (WEEE)

SHEV control panel EMB8000+

Order information – Accessories



Timer

- Time-controlled opening and closing of ventilation lines with day and week programme (30 programme slots)
- Connection to the ventilation push-button input of SHEV and/or ventilation control units
- Installed at the factory and pre-wired ready for operation

Technical data	
Operating voltage	230 V AC
Contact version	1 x Um
Switching capacity	230 V AC / 16 A
Cylinder body	PVC, white, for 35 mm top-hat rail
Dimensions (W x H x D)	17.6 x 63 x 90 mm
Connections	Screw-type terminals 1.5 mm ² (rigid)
Protection code	IP20

	PU	Order number	
	1 pc	659927-9	



Temperature sensor

- Temperature sensor PM for emergency supply to EMB8000+ SHEV control units
- Conductor with connecting piece

Technical data	
Hardware	REV.1
Bootloader	BL V0.0.10
Application	V0.0.17
Cable	0.09 mm ² AWG28; RM1.27
Certification	CE

Specification	PU	Order number	
PM 0.4 m	1 pc	680055	
PM 0.9 m	1 pc	680056	

SHEV control panel EMB8000+

Order information – accessories and services

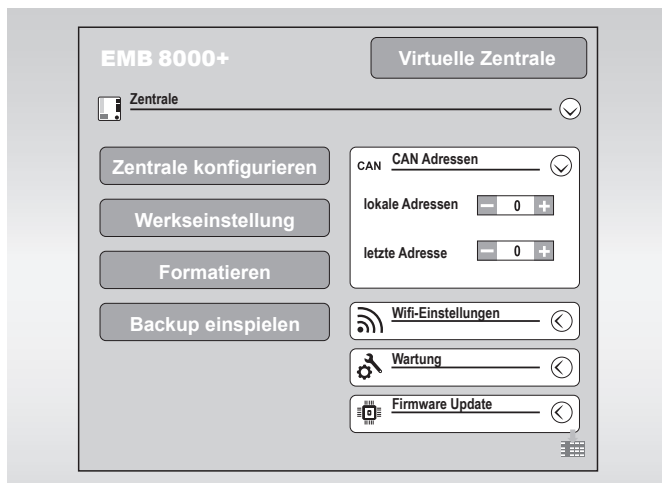

Software licence EMB8000+ DCT

- Software licence for configuring, programming, networking and maintenance of EMB8000+ modular control units
- System prerequisites: Microsoft® Windows 10 64 Bit

Specification	PU	Order number	
Licence for 1 month*	1 pc	688911	
Licence for 3 years*	1 pc	688913	

Services

Specification		PU	Order number	
Plan creation	Cable plan per SHEV / ventilation group	1 pc	240	
Programming	Programming of a EMB8000+ control unit at the factory	1 pc	688930	
Support with online commissioning		1 h	SL125	

* Licence is only issued once training has been given

SHEV control panel EMB7300 and EMB8000+

Order information – Accessories



Push-button fire alarm switch HSE metal Main control unit

Application

- Manual call point with displays for manual activation of EMERGENCY OPEN function and the close function of a SHEV group via the signalling lines of an SHEV control unit

Product characteristics

- Lockable, glazed door (incl. key)
- Connection to the signalling line input
- The terminating resistor is activated or deactivated via a DIP switch

Technical data	
Operating voltage	24 V DC
Ambient temperature	-5 °C to +40 °C
Cylinder body	Surface-mounted, aluminium
Dimensions (W x H x D)	130 x 130 x 32 mm
Connections	Spring-type terminals 1.0 mm ² (rigid)
Protection code	IP30
Displays	EMERGENCY OPEN, operation, fault
Operating elements	EMERGENCY OPEN push-button, CLOSE push-button

Specification	PU	Order number	
orange (similar to RAL 2011)	1 pc	528400	
red (similar to RAL 3000)	1 pc	528401	
yellow (similar to RAL 1018)	1 pc	528402	
blue (similar to RAL 5015)	1 pc	528403	
grey (similar to RAL 7035)	1 pc	528404	

SHEV control panel EMB7300 and EMB8000+

Order information – Accessories



Push-button fire alarm switch HSE plastic Main control unit

Application

- Manual call point with displays for manual activation of EMERGENCY OPEN and CLOSE functions of a SHEV group via the signalling lines of an SHEV control unit

Product characteristics

- Lockable, glazed door (incl. key)
- Connection to the signalling line input
- HSE orange: VdS approval number G 501006

Technical data	
Operating voltage	24 V DC
Ambient temperature	-5 °C to +40 °C
Cylinder body	Surface-mounted, PVC (ABS)
Dimensions (W x H x D)	130 x 130 x 32 mm
Connections	Screw-type terminal 1.0 mm ² (rigid)
Protection code	IP30
Displays	EMERGENCY OPEN, operation, fault
Operating elements	EMERGENCY OPEN push-button, CLOSE push-button

Versions	PU	Order number	
red (similar to RAL 3000)	1 pc	528691	
yellow (similar to RAL 1018)	1 pc	528692	
grey (similar to RAL 7035)	1 pc	528693	
blue (similar to RAL 5015)	1 pc	528694	
orange (similar to RAL 2011)	1 pc	528695	

SHEV control panel EMB7300 and EMB8000+

Order information – Accessories



Push-button fire alarm switch HSE-N metal Secondary control point

Application

- Manual call point with display for manual activation of EMERGENCY OPEN function of an SHEV group via the signalling lines of an SHEV control unit

Product characteristics

- Lockable, glazed door (incl. key)
- Connection to the signalling line input
- The terminating resistor is activated or deactivated via a DIP switch

Technical data	
Operating voltage	24 V DC
Ambient temperature	-5 °C to +40 °C
Cylinder body	Surface-mounted, aluminium
Dimensions (W x H x D)	130 x 130 x 32 mm
Connections	Spring-type terminals 1.0 mm ² (rigid)
Protection code	IP30
Displays	EMERGENCY-OPEN
Operating elements	EMERGENCY OPEN push-button

Specification	PU	Order number	
orange (similar to RAL 2011)	1 pc	528410	
red (similar to RAL 3000)	1 pc	528411	
yellow (similar to RAL 1018)	1 pc	528412	
blue (similar to RAL 5015)	1 pc	528413	
grey (similar to RAL 7035)	1 pc	528414	

SHEV control panel EMB7300 and EMB8000+

Order information – Accessories



Push-button fire alarm switch HSE-N plastic Secondary control point

Application

- Manual call point with display for manual activation of EMERGENCY OPEN function of an SHEV group via the signalling lines of an SHEV control unit

Product characteristics

- Lockable, glazed door (incl. key)
- Connection to the signalling line input
- HSE orange: VdS approval number G 501006

Technical data	
Operating voltage	24 V DC
Ambient temperature	-5 °C to +40 °C
Cylinder body	Surface-mounted, PVC (ABS)
Dimensions (W x H x D)	130 x 130 x 32 mm
Connections	Screw-type terminal 1.0 mm ² (rigid)
Protection code	IP30
Displays	EMERGENCY-OPEN
Operating elements	EMERGENCY OPEN push-button

Versions	PU	Order number	
red (similar to RAL 3000)	1 pc	525001	
yellow (similar to RAL 1018)	1 pc	525002	
grey (similar to RAL 7035)	1 pc	525003	
blue (similar to RAL 5015)	1 pc	525004	
orange (similar to RAL 2011)	1 pc	525005	

SHEV control panel EMB7300 and EMB8000+

Order information – Accessories



Push-button fire alarm switch HSE plastic BUS Main control unit

Application

- Manual call point with displays for manual activation of EMERGENCY OPEN function and the close function of a SHEV group via the BUS line of an SHEV control unit

Product characteristics

- Lockable, glazed door (incl. key)
- Connection to the BUS signalling line input

Technical data	
Operating voltage	24 V DC
Ambient temperature	-5 °C to +40 °C
Cylinder body	Surface-mounted, PVC (ABS)
Dimensions (W x H x D)	130 x 130 x 32 mm
Connections	BUS terminal 2 x 0.8 mm ²
Protection code	IP30
Displays	EMERGENCY OPEN, operation, fault
Operating elements	EMERGENCY OPEN push-button, CLOSE push-button
Connection option	Ventilation push-button input Screw-type terminals 1.0 mm ² (rigid)

Specification	PU	Order number	
orange (similar to RAL 2011)	1 pc	528495	
red (similar to RAL 3000)	1 pc	528491	
yellow (similar to RAL 1018)	1 pc	528492	
blue (similar to RAL 5015)	1 pc	528494	
grey (similar to RAL 7035)	1 pc	528493	

SHEV control panel EMB7300 and EMB8000+

Order information – Accessories

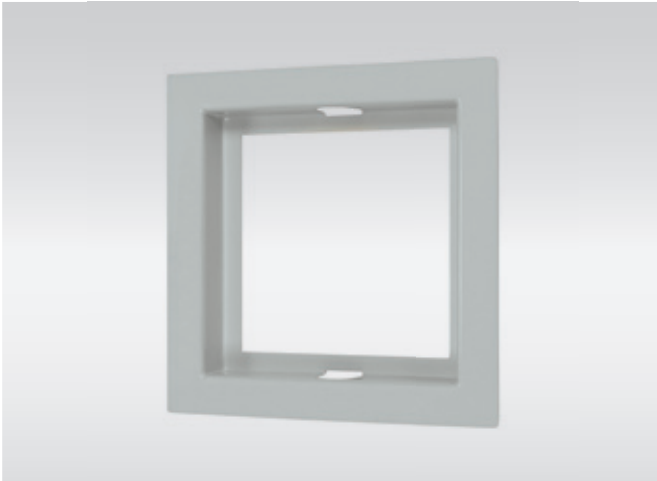

Frame for HSE flush-mounted installation

Application

- For flush mounting of 130 x 130 x 32 mm HSE push-buttons

Technical data	
Cylinder body	Surface-mounted, sheet steel
Dimensions (W x H x D)	171 x 171 x 26 mm
Installation dimension	140 x 140 x 30 mm

Finish	PU	Order number	
Light grey powder-coated unpatterned	1 pc	528015	

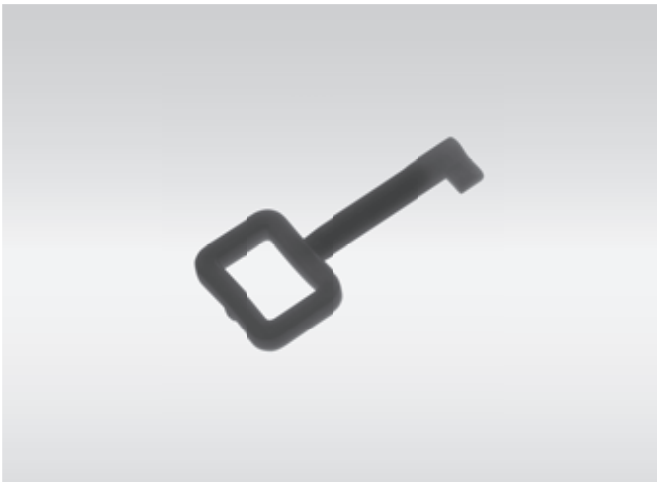

Replacement key

Application

- For opening and closing the door of 130 x 130 x 32 mm HSE push-buttons

Order number	PU	Order number	
for push-button fire alarm switches made of plastic			
PVC	1 pc	527007	
for push-button fire alarm switches made of aluminium			
Metal	10 pc	527008	

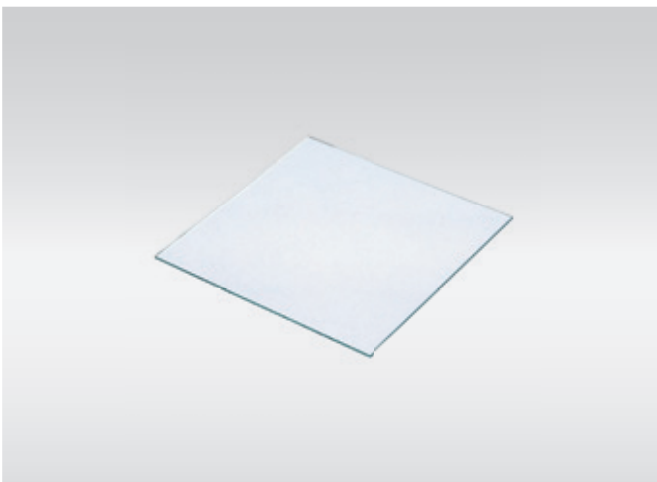

Replacement glass

Application

- Glass panels for on-site replacement
- Dimensions (W x H x D): 80 x 80 x 0.7 mm
- Suitable for 130 x 130 x 32 mm HSE push-buttons

	PU	Order number	
	10 pc	527002	

SHEV control panel EMB7300 and EMB8000+

Order information – Accessories



Optical BUS smoke switch

Application

- For automatic early triggering of the EMERGENCY OPEN function via the BUS signalling line of the EMB8000+ when smoke is present in the area under surveillance

Product characteristics

- Fire algorithms for avoiding false/hoax alarms and for tracking of alarm thresholds
- Tested in accordance with EN 54-7
- Connection to the BUS signalling line input
- VdS approval number G 209219

Technical data	
Measuring element	Photoelectric / stray light principle
Operating voltage	24 V DC via BUS
Closed-circuit current consumption	< 110 µA
Cylinder body	Surface-mounted, plastic (ABS), signal white (similar to RAL 9003)
Dimensions (Ø x H)	120 x 60 mm
Connections	Screw-type terminals 1.0 mm ² (rigid)
Protection code	IP30
Ambient temperature	-10 °C to +55 °C
Displays	Alarm triggered

	PU	Order number
	1 pc	531530 

SHEV control panel EMB7300 and EMB8000+

Order information – Accessories



Optical smoke detector

- For automatic early triggering of the EMERGENCY OPEN function via a signalling line of SHEV control units when smoke is present in the area under surveillance

Product characteristics

- Fire algorithms for avoiding false/hoax alarms and for tracking of alarm thresholds
- Tested in accordance with EN 54-7
- Connection to the signalling line input

Technical data	
Measuring element	Photoelectric / stray light principle
Operating voltage	8.5–33 V DC
Closed-circuit current consumption	< 100 µA
Cylinder body	Surface-mounted, plastic (ABS), electrowhite
Dimensions (Ø x H)	100 x 50 mm
Connections	Screw-type terminals 1.0 mm ² (rigid)
Protection code	IP23D
Displays	Alarm triggered

	PU	Order number	
	1 pc	531520	

Protector against thrown balls

Application

- Chrome-plated steel grid, e.g. for use in sports halls/ gymnasiums

	PU	Order number	
	1 pc	513546	

SHEV control panel EMB7300 and EMB8000+

Order information – Accessories



Connecting module BMZ

Application

- For automatic triggering of the EMERGENCY OPEN function of a SHEV control unit via a potential-free contact of the fire alarm system

Product characteristics

- Connection to the signalling line input
- Line monitoring between control unit and module

Technical data	
Operating voltage	24 V DC
Closed-current consumption	< 10 mA
Ambient temperature	0 °C to +40 °C
Dimensions (W x H x D)	27 x 19 x 13 mm
Connections	Screw-type terminals 1.5 mm ² (rigid)
FACP contact	NO contact in the event of alarm triggering

	PU	Order number	
	1 pc	670053	



Line terminal module

Application

- Installation in the last or only socket of the drive line for line monitoring

Technical data	
Operating voltage	24 V DC (± 5 %)
Closed-current consumption	< 10 mA
Ambient temperature	0 °C to +70 °C
Dimensions (W x H x D)	27 x 19 x 13 mm
Connections	3 single wires

	PU	Order number	
	1 pc	670052	



Ventilation control unit LZ

Product characteristics



Product characteristics

- Control centre with accessories such as weather detector and control units for activation of 24 V DC drives driven by electric motor for natural in/out ventilation of rooms and buildings
- Output voltage with low residual ripple (< 2 Vpp)
- Ventilation control units which can be connected in parallel (cascadable)
- Combination of several ventilation groups in one control unit
- All ventilation push-button inputs equipped with OPEN-STOP-CLOSE function and sometimes 2 or 3 switching priorities
- Configurable outputs for activation in latching or deadman mode
- Drive lines protected individually
- Input for higher-level signals, e.g. potential-free wind and rain signals
- Suitable for integration in systems for controlled natural ventilation
- Various display and control elements
- Flat surface-mounted housing, suitable for installation in false floors or suspended ceilings
- Optional BUS interface for integration in central building control systems via LON and KNX
- Digital interface for S12 drives

Ventilation control unit LZ

Technical data



Technical data

Specification	LZ 1	LZ 6
Operating voltage	230 V AC (195 – 253 V AC, 50/60 Hz)	230 V AC (195 – 253 V AC, 50/60 Hz)
Max. power consumption	60 W	506 W / 805 W / 1518 W [1]
Output voltage	24 V DC (20 – 28 V DC / 2 Vpp)	24 V DC (20 – 28 V DC / 0.5 Vpp)
Output current	2.5 A	10 A / 24 A / 30 A [1]
Inputs	1 x ventilation push-button line with 3 priorities	6 x ventilation push-button lines each with 2 priorities (P3: LOW; P2: HIGH) 1 x central input OPEN/CLOSE (P1)
Outputs	1 x drive line 1 x 24 V DC / 500 mA (e.g. for rain sensor)	6 x drive lines 1 x 24 V DC / 500 mA (e.g. for rain sensor)
Displays	Operation, output voltage in OPEN/CLOSE direction	Operation, output voltage in OPEN/CLOSE direction
Slots	BUS modules (LON, KNX)	For optional BUS module (LON / KNX)
Connections	S12 drives for communiation with BUS modules	–
Cylinder body	Surface-mounted, PVC (ABS)	Surface-mounted, sheet-steel, RAL 7035 (light grey)
Dimensions (W x H x D)	180 x 130 x 60 mm	420 x 300 x 144 mm
Connection terminals	Screw-type terminals 2.5 mm ² (rigid)	Screw-type terminals 2.5 mm ² (rigid)
Protection code	IP54	IP30

[1] depending on version

Ventilation control unit LZ

Order information – version LZ1 / LZ6

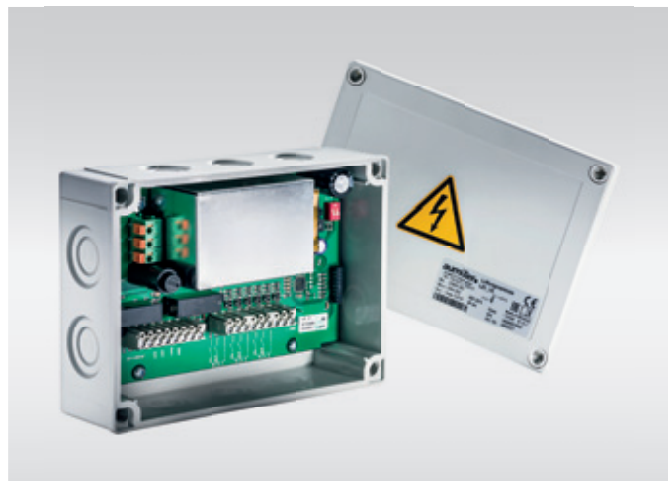

Ventilation control unit LZ1 2.5 A

- Ventilation control unit with power supply for activation of 24 V DC drives; with a ventilation line
- DIP switch for configuration of input with lowest priority in locking or deadman operating mode
- Inputs of several LZ1 and/or LZ6 can be connected in parallel
- When using a BUS module, drives with intelligent load cut-off (S12) can be activated via the BUS protocol to achieve controlled natural ventilation

Specification		PU	Order number	
LZ1 2.5 A	without BI-K	1 pc	660027	
	with BI-K	1 pc	660028	



LZ 6 ventilation central control unit

- Ventilation control unit with switched-mode power supply for activation of 24 V DC drives; with 6 ventilation lines
- DIP switch for configuration of priority P3 of all inputs in locking or deadman operating mode
- Inputs of several LZ1 and/or LZ6 can be connected in parallel, any inputs can be interconnected to form groups
- Outputs with individual fuse protection

Specification	Output current	PU	Order number	
LZ6 10 A	6 x 1.6 A	1 pc	660070	
LZ6 24 A	6 x 4.0 A	1 pc	660071	
LZ6 30 A	6 x 5.0 A	1 pc	660072	

Ventilation control unit LZ

Order information – Accessories



NT-T-2.5 power supply unit

- Power supply unit with transformer for power supply and activation of 24 V DC drives; with a ventilation line
- Activation in OPEN/CLOSE direction via the 230 V AC mains voltage

Technical data	
Operating voltage	230 V AC ($\pm 10\%$)
Power consumption	60 W
Output voltage	24 V DC (21 – 28 V DC)
Output current	2.5 A
Duty ratio	20 % (10 min.)
Ambient temperature	-5 °C to +40 °C
Cylinder body	Surface-mounted, PVC (ABS)
Dimensions (W x H x D)	94 x 180 x 81 mm
Connection terminals	Screw-type terminals 2.5 mm ² (230 V) / 4 mm ² (24 V) (rigid)
Protection code	IP54

	PU	Order number	
	1 pc	660009	

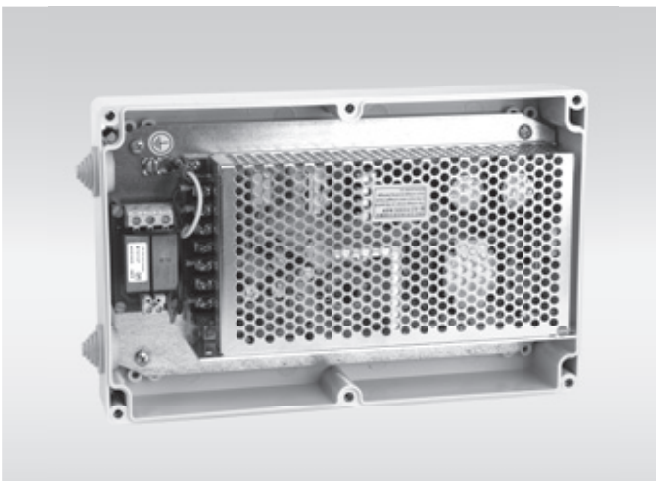

NT-S-6.5 power supply unit

- Switched-mode power supply unit for power supply and activation of 24 V DC drives; with a ventilation line
- Activation in OPEN/CLOSE direction via the 230 V AC mains voltage
- Parallel connection of max. 8 power supply units

Technical data	
Operating voltage	230 V AC (195 – 253 V AC, 50/60 Hz)
Power consumption	460 W
Output voltage	24 V DC (2 Vpp)
Output current	6.5 A
Duty ratio	30 % (10 min.)
Ambient temperature	-5 °C to +40 °C
Cylinder body	Surface-mounted, PVC (ABS)
Dimensions (W x H x D)	160 x 250 x 55 mm
Connection terminals	Screw-type terminals 4 mm ² (rigid)
Protection code	IP54

	PU	Order number	
	1 pc	660007	

Ventilation control unit LZ

Order information – Accessories

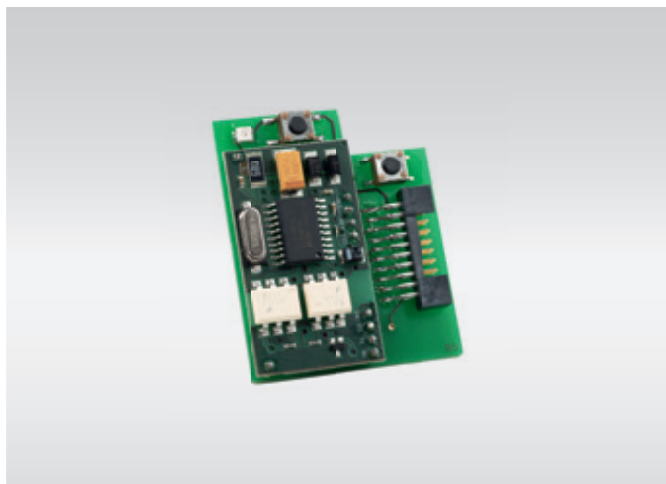

BI-K – KNX Interface LZ1 / LZ6 / EMB7300

- Plug-in card for communication between control units LZ1, LZ6 and EMB7300 on the KNX-BUS system

Product characteristics

- Control unit data (e.g. drive position) is transmitted on the KNX-BUS
- The control units receive direct commands from the KNX-BUS (e.g. position data, weather data)
- The licensed version of the EMB compact configurator is required for commissioning

Technical data	
Operating voltage	24 V DC
Ambient temperature	-5 °C to +40 °C
Relative air humidity (not condensate)	5 % up to 90 %
Data points	up to 16 pcs per motor line
BUS power	9 mA
Dimensions (W x H)	51 x 42 mm
Connection terminals	2 x 2 x 0.8 mm (KNX-BUS terminal)

Specification	PU	Order number
Dispatch for self-installation by customer	1 pc	683999
Installed at the factory and pre-wired ready for operation	1 pc	683999-9

Ventilation control unit LZ

Order information – Accessories



2-channel radio receiver RR2

- High-performance reliable 2-channel receiver with 2 switching contacts
- Very small
- Suitable for installation in a flush box
- Microprocessor with decoding function
- Independent learning of wireless controls
- With self-learning/configuration push-button, including LED display and LED buzzer
- Up to 30 remote control units can be saved (depending on the coding type used)
- Digital interference filter for improving the radio performance

Technical data	
Nominal voltage	230 V AC, 50/60 Hz
Operating frequency	433.92 MHz
Power consumption	Standby: 0.3 W With an active relay: 0.8 W With two active relays: 1.4 W
Dimensions (W x H x D)	42 x 21 x 36 mm
Protection code	IP20
Approx. transmission range	In the open air: 150 m For indoor use: 20 m

	PU	Order number
	1 pc	K-20205-00-0-0



Radio remote control

- Multi-channel remote control for individual and group control in combination with 2-channel radio receiver RR2
- Microprocessor-controlled
- With display for functions, transmission status and battery charge level
- Dimensions (W x H x D): 38.5 x 145 x 22.5 mm
- Transmission range approx. 50 m

	PU	Order number
	1 pc	K-19046-00-0-0

Manual ventilation components

Ventilation push-button



Ventilation push-button 24 V DC

- For connection to the ventilation push-button inputs of SHEV and/or ventilation control units
- Push-button without mechanical locking, stop function can be activated by pressing both push-buttons

Technical data		
Contact version	2 x NO contact	
Switching capacity max.	230 V AC / 10 A	
Cylinder body	Plastic, white (similar to RAL 9016)	
Dimensions (W x H x D)	On-wall version	81 x 81 x 54 mm
	In-wall version	81 x 81 x 11 mm (visible areas)
Connections	Plug terminals 1.5 mm ² (rigid)	
Protection code	IP20	
Push-button function	OPEN – CLOSE	

Specification	PU	Order number	
On-wall version	1 pc	529030	
Flush-mounted*	1 pc	529230	



Ventilation push-button 230 V AC

- For connection to ventilation push-button inputs of 230 V AC power supply units, or for direct activation of 230 V AC drives
- Push-button with mechanical locking, drives only run while a push-button is pressed

Technical data		
Contact version	2 x NO contact	
Switching capacity max.	230 V AC / 10 A	
Cylinder body	Plastic, white (similar to RAL 9016)	
Dimensions (W x H x D)	On-wall version	81 x 81 x 54 mm
	In-wall version	81 x 81 x 11 mm (visible areas)
Connections	Plug terminals 1.5 mm ² (rigid)	
Protection code	IP20	
Push-button function	OPEN – CLOSE in deadman	

Specification	PU	Order number	
On-wall version	1 pc	529530	
Flush-mounted*	1 pc	529630	

*For installation in flush-mounted cans Ø 60 mm.

Manual ventilation components

Spring-operated key switch



Spring-operated key switch

- For connection to the ventilation push-button inputs of SHEV and/or ventilation control units
- Push-button with profile half-cylinder (DIN 19525) and 3 keys

Technical data		
Contact version	2 x NO contact	
Switching capacity max.	230 V AC / 10 A	
Cylinder body	Plastic, white (similar to RAL 9016)	
Dimensions (W x H x D)	On-wall version	81 x 81 x 54 mm
	In-wall version	81 x 81 x 11 mm (visible areas)
Connections	Plug terminals 1.5 mm ² (rigid)	
Protection code	IP20	
Push-button function	OPEN – STOP – CLOSE	

Specification	PU	Order number	
On-wall version	1 pc	529350	
Flush-mounted*	1 pc	529450	

*For installation in flush-mounted cans Ø 60 mm.

Automatic ventilation components

CO2 air quality sensor, room temperature sensor



CO2 air quality sensor

- For recording and evaluating the CO2 concentration in the air
- Connection to the ventilation push-button input of SHEV and/or ventilation control units

Technical data	
Operating voltage	24 V DC ($\pm 5\%$)
Measuring element	Electronic
Contact version	2 x NO contact
Pulse duration	3,5 s
Switching capacity	230 V AC / 0.5 A
Measuring range	0 – 3000 ppm CO2
Cylinder body	Surface-mounted, PVC white
Dimensions (W x H x D)	78 x 78 x 35 mm
Connections	Screw-type terminals 1.5 mm ² (rigid)
Protection code	IP30
Displays	3 x LED (green, yellow, red)

	PU	Order number	
	1 pc	483710	



Room temperature controller

- Thermostat as two-point controller for recording the room temperature
- Connection to the ventilation push-button input of SHEV and/or ventilation control units

Technical data	
Measuring element	Bimetallic switch
Contact version	1 x Um
Switching capacity	230 V AC / 5 A
Adjustment range	0 – 30 °C
Cylinder body	Surface-mounted, PVC white
Dimensions (W x H x D)	74.5 x 74.5 x 25 mm
Connections	Screw-type terminals 1.5 mm ² (rigid)
Protection code	IP30

	PU	Order number	
	1 pc	483200	

Automatic ventilation components

Wind and rain sensor set



Wind and rain sensor set

- Recording and forwarding of wind speed and rain status signal to an evaluation unit, WM module or directly to a SHEV control unit which closes and locks the ventilation function during inclement weather conditions

Set consisting of:

- Wind sensor type III (482021)
 - Anemometer with 3 impact-resistant wind scoops (PA6)
- Regenkompaktsensor Typ III (480210)
 - Heated sensor surface, hysteresis roughly 5 min.
- Clamping ring (515950)
- Mounting bracket made of aluminium for mounting on mast or wall (482093) (without fixing screws)

Technical data	
Nominal voltage	24 V DC ($\pm 20\%$)
Wind sensor type III	
Measurement principle	Pulse generator
Dimensions	250 x 250 x 80 mm
Connecting cable	Halogen-free, approx. 4 m
Rain compact sensor type III	
Power consumption	< 150 mA
Cylinder body	Surface-mounted, ABS, black, with stainless steel holder
Dimensions (W x H x D)	100 x 85 x 172 mm
Connecting cable	Halogen-free, approx. 4 m
Potential-free contact	1 x Um, max. 48 V / 5 A

Specification	PU	Order number	
WR set type 7x/8x	1 pc	482100	

Automatic ventilation components

Wind sensor



Wind sensor type III

- Anemometer with 3 impact-resistant wind scoops (PA6) for recording the wind speed
- Connection to: RZ and EMB7300 compact control units, weather module WM of the EMB8000+ modular control units, wind and rain evaluation units WRAG2
- With clamping ring for installation on all wall/floor mounting brackets with outer diameter \varnothing 36 mm

Technical data	
Operating voltage	24 V DC (\pm 20 %)
Measurement principle	Pulse generator, ball-bearing mounted
Cylinder body	Aluminium \varnothing 36 mm, untreated
Shells	PA6, black
Dimensions	250 x 250 x 80 mm
Connecting cable	Halogen-free, approx. 4 m

Specification	PU	Order number	
Wind sensor type III	1 pc	482021	
Spare parts for wind sensor type III			
Shells	1 pc	490601	
Clamping ring	1 pc	515950	

Automatic ventilation components

Rain compact sensor

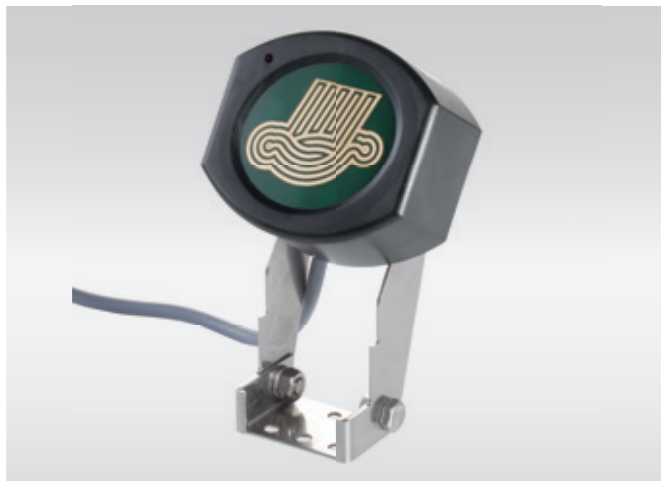

Rain compact sensor type III 24 V DC

- Rain sensor according to conductivity measurement principle with heated sensor surface and integrated evaluation electronics with potential-free contact for signal forwarding
- Connection to: RZ and EMB7300 compact control units, weather module WM of the EMB8000+ modular control units, wind and rain evaluation units WRAG2

Technical data	
Operating voltage	24 V DC ($\pm 20\%$)
Power consumption	< 150 mA
Measurement principle	Conductivity measurement, heated sensor
Hysteresis	5 min.
Display	Output active
Output	1 x Um, 5 A / max. 48 V
Protection code	IP65
Cylinder body	Surface-mounted, ABS, black, with stainless steel mounting bracket
Dimensions	100 x 85 x 172 mm
Connecting cable	Halogen-free, approx. 4 m

Specification	PU	Order number
Rain compact sensor type III	1 pc	480210 

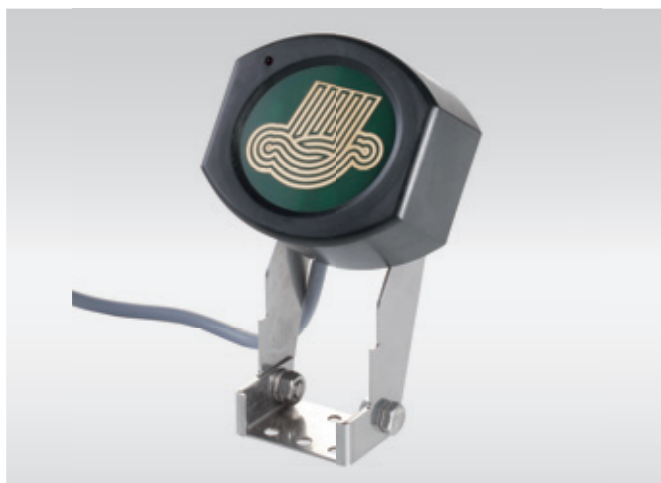

Rain compact sensor type III 230 V AC

- Rain sensor according to conductivity measurement principle with heated sensor surface and integrated evaluation electronics with potential-free contact for signal forwarding
- Single unit to be supplied from the mains

Technical data	
Operating voltage	230 V AC (50 Hz)
Power consumption	< 1.5 VA
Measurement principle	Conductivity measurement, heated sensor
Display	Output active
Output	1 x Um, 5 A / max. 230 AC
Protection code	IP65
Cylinder body	Surface-mounted, ABS, black, with stainless steel mounting bracket
Dimensions	100 x 85 x 172 mm
Connecting cable	Halogen-free, approx. 4 m

Specification	PU	Order number
Rain compact sensor type III	1 pc	480110 

Automatic ventilation components

Wind and rain sensor set – mounting accessories

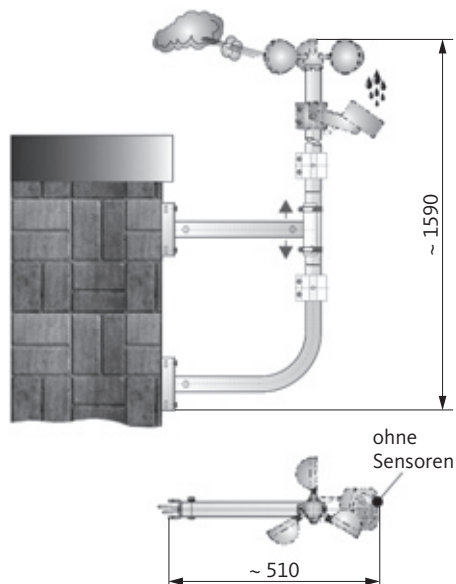

Wall bracket for wind and rain sensor set

- Reinforced wall mounting bracket with double fixing for wind and rain sensors
- Without fixing screws, without sensors

Technical data	
Total height	approx. 1590 mm
Projection	approx. 510 mm
Order number	Aluminium, untreated

	PU	Order number	
	1 pc	491200	

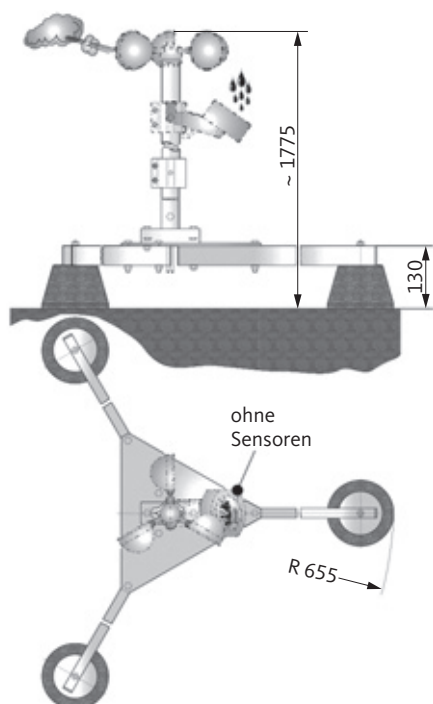

Floor mounting bracket for wind and rain sensor set

- Floor mounting bracket with 3 rugged concrete feet for fastening wind and rain sensors to flat roofs
- Without sensors

Technical data	
Total height	approx. 1775 mm
Standing surface	approx. Ø 1310 mm
Order number	Aluminium, untreated

	PU	Order number	
	1 pc	491101	

Automatic ventilation components

Wind direction sensor set, post/wall bracket



Wind direction sensor set

- Recording and forwarding of wind direction to an evaluation unit or a WM module for opening/closing of smoke extraction openings depending on the wind direction in the event of fire

Set consisting of:

- Wind direction sensor, connection box (482110), clamping ring (515950), mounting bracket for installation on mast/wall (482093)

Technical data		
Operating voltage	24 V DC ($\pm 20\%$)	
Wind direction sensor	Ball-bearing mounted measuring element with wind vane	
Measuring range	8 wind directions	
Order number	Rotary head	PA6 black
	Wind vane	Stainless steel
Connecting cable	Halogen-free, 6 x 0.34 mm ² , approx. 3 m	
Connection box	With PCB and screw-type terminals	
Connections	WRG, wind sensor type III, rain sensor type III	
Housing (W x H x D)	110 x 110 x 66 mm / IP54	
Connections	Screw-type terminals 1.5 mm ² (rigid)	

Specification	PU	Order number	
WRG set	1 pc	482120	



Mast/wall mounting bracket for wind and rain sensor

- Mounting bracket for pole or wall mounting
- Without fixing screws

Technical data	
Pipe bend	
Order number	Aluminium EV1
Dimensions	$\varnothing 36 \times 2$ mm
Length	488.5 mm
Connecting piece	
Order number	AlSi12
Dimensions (W x H x D)	45 x 120 x 80 mm

	PU	Order number	
	1 pc	482093	

Automatic ventilation components

Wind/rain evaluation unit



Wind/rain evaluation unit

- Evaluation and potential-free forwarding of wind and rain status signal
- For connection of wind and rain sensor set type 7x/8x or 24 V DC rain compact sensor
- Connection of e.g. additional ventilation push-buttons or time switch is possible
- Setting for forwarding of wind and rain signals separately or jointly can be made via 4 DIP switches
- Direct connection of drives (max. total current consumption 5 A) possible
- Switch-on delay with wind and rain
- Switch-off delay with wind

Technical data	
Operating voltage	230 V AC, 50 Hz
Closed-current consumption	< 100 mA
Inputs	Rain sensor 24 V DC, wind sensor, ventilation push-button
Displays	Operation, wind, rain
Wind speed	2.5 – 20 m/s, adjustable
Outputs	2 x Um, 230 V AC / 5 A
Cylinder body	PVC Upper part RAL 7035 / Lower part RAL 7021
Dimensions (W x H x D)	105 x 86 x 58 mm
Installation	35 mm top-hat rail
Connections	Screw-type terminals 1.5 mm ² (rigid)
Protection code	IP40

Specification	PU	Order number
WRAG2	1 pc	482005 

Automatic ventilation components

Relay, distribution-board housing

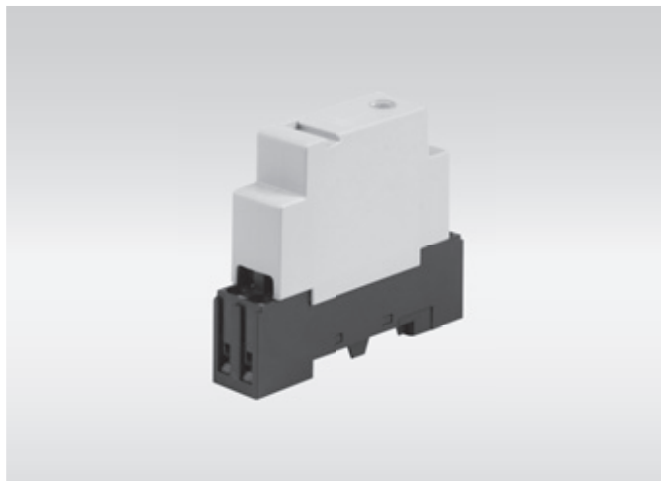

Relay for contact duplication

- Relay for multiplying the output signals of WRAG2 wind and rain evaluators.
- Including base for mounting on 35 mm top-hat rail

Technical data	
Operating voltage	230 V AC, 50 Hz
Contact version	2 x Um
Switching capacity	230 V / 8 A
Connections	Screw-type terminals 1.5 mm ² (rigid)

Specification	PU	Order number	
REL-WRAG2	1 pc	487020	



Compact distribution-board housing for WRAG2

- Surface-mounted distribution-board housing for installation of a WRAG2 wind and rain evaluation unit and max. 2 relays
- Without fixing screws; without cover strips

Technical data	
Cylinder body	Surface-mounted, PVC (ABS)
Dimensions (W x H x D)	182 x 180 x 82 mm
Protection code	IP30
Reserve space	2 x REL-WRAG2

	PU	Order number	
	1 pc	482011	



Distribution-board housing for WRAG2

- Surface-mounted distribution-board housing for installation of a WRAG2 wind and rain evaluation unit and max. 6 relays
- Without fixing screws; without cover strips

Technical data	
Cylinder body	Surface-mounted, PVC (ABS)
Dimensions (W x H x D)	303 x 245 x 95 mm
Protection code	IP30
Reserve space	6 x REL-WRAG2

	PU	Order number	
	1 pc	482015	

Automatic ventilation components

Smart Vent Box



Smart Vent Box Flex

- For digital activation of "OPEN" or "CLOSE" running direction
- Suitable for connection to 24 V DC S12 drives

Technical data	
Operating voltage	24 V DC (19 – 28 V DC)
Connections	1 x drive group 1 x input for external higher-level signals 1 x ventilation push-button connection
Ambient temperature	-5 °C to +40 °C
Dimensions (W x H x D)	40.5 x 48.5 x 28.3 mm
Connection terminals	9 x spring-type terminal, max. 1.5 mm ²
Protection code	IP20

Specification	PU	Order number	
SVB Flex	1 pc	660110	



Smart Vent Box 0–10 V

- For analogue activation of "OPEN" or "CLOSE" running direction
- Suitable for connection to 24 V DC S12 drives

Technical data	
Operating voltage	24 V DC (19 – 28 V DC)
Connections	1 x drive group 1 x input for external higher-level signals 1 x 0 – 10 V input 1 x signalling output
Ambient temperature	-5 °C to +40 °C
Dimensions (W x H x D)	40.5 x 48.5 x 28.3 mm
Connection terminals	9 x spring-type terminal, max. 1.5 mm ²
Protection code	IP20

Specification	PU	Order number	
SVB 0–10 V	1 pc	660120	

Automatic ventilation components

Smart Vent Box



Smart Vent Box KNX

- For integration into an existing building control system with KNX system
- Suitable for connection to 24 V DC S12 drives

Technical data	
Operating voltage	24 V DC (19 – 28 V DC)
Connections	1 x drive group 1 x ventilation push-button connection (optional) 1 x KNX connection
Ambient temperature	-5 °C to +40 °C
Dimensions (W x H x D)	40.5 x 48.5 x 28.3 mm
Connection terminals	1 x BUS plug terminal, max. 1.5 mm ²
Protection code	IP20

Specification	PU	Order number	
SVB KNX	1 pc	660140	



Smart Vent Box Modbus

- For integration into an existing building control system with Modbus communication
- Suitable for connection to 24 V DC S12 drives

Technical data	
Operating voltage	24 V DC (19 – 28 V DC)
Connections	1 x drive group 1 x ventilation push-button connection (optional) 1 x Modbus connection
Ambient temperature	-5 °C to +40 °C
Dimensions (W x H x D)	40.5 x 48.5 x 28.3 mm
Connection terminals	1 x BUS plug terminal, max. 1.5 mm ²
Protection code	IP20

Specification	PU	Order number	
SVB Modbus	1 pc	660130	

Automatic ventilation components

Information signs



Sign "Smoke exhaust"

- According to DIN 4066

Technical data	
Material	Aluminium
Dimensions (W x H x D)	210 x 75 x 1 mm

PU	Order number
1 pc	9-22277-00-0-0



Sign "Ventilation"

Technical data	
Material	Aluminium
Dimensions (W x H x D)	210 x 75 x 1 mm

PU	Order number
1 pc	9-25546-00-0-0

Automatic ventilation components

Test log book



Test log book

- Acceptance report
- Documentation for smoke and heat exhaust ventilation systems
- Verification of maintenance carried out
- Checklists for the function test and commissioning

	PU	Order number
	1 pc	K-18165-00-0-0





3.0 Fanlight opening systems

3.1 Electric actuation

with electric drive ELTRAL S 24

324

3.2 Electric actuation

with electric drive ELTRAL S 230

336

3.3 Manual operation

with hand lever or crank

348

3.4 Electric and manual actuation

Individual components

390

3.5 Accessories

GU restrictor and cleaning stay EURO-SOLID

438

Fanlight opening system VENTUS F200

Electrical operation with electrical drive ELTRAL S 24



The fanlight opening system, consisting of the fanlight opener VENTUS and the electrical drive ELTRAL, enables a cost-effective electromechanical control of several sash units. Due to the flat design of the opening stays, the system can be used for smoke exhaust and daily ventilation on inward opening, vertically

installed square Bottom-Hung windows made of timber, PVC or metal with low space conditions. The automatic locking in the stays and the optional additional locking on the sash enable a high pressing force and therefore increase the tightness of the seal on the sash. The system is easy to install and operate.

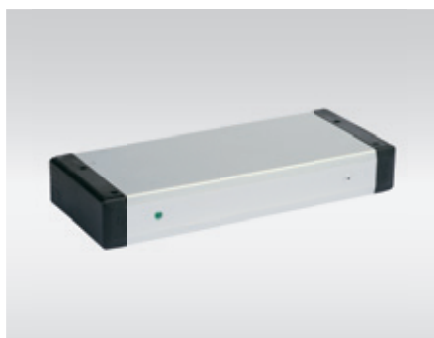

Powerful drive ELTRAL S 24

Advantages at a glance

- Additional potential for economic savings thanks to controlling several sashes with just one drive 
- Ideally suited for windows offering limited mounting space
- Variable opening width setting

Fanlight opening system VENTUS F200

System features



System features

- Opening widths up to 200 mm for low sash heights from 300 mm
- Simple installation, horizontal or vertical (left/right)
- With position and function display
- Optional for increased security: operation of the concealed central locking system UNI-JET/ALU-JET via a dog
- Adjustable travel for variable opening widths
- Aluminium housing
- Electrical drive ELTRAL S can also be used on lamella windows
- Opening stay can be easily unhinged for convenient window cleaning

Technical data

VENTUS F200 | Electrical operation with electrical drive ELTRAL S 24 | Bottom-Hung window

Drive	Max. sash width [mm]	Min. sash width [mm]		Min. sash height [mm]	Max. sash weight [kg]	Infill weight max. [kg/m ²]	Space requirement Drive [mm]	
		lateral	top				lateral	top
ELTRAL S 24	3600	410	630	300	80	40 ^[1]	39	39

[1] Depending on "dimension S" (= distance from sash centre of gravity to middle of hinge) and sash width

ELTRAL S 24 electric drives

Drive	Rated voltage DC [V]	Nominal force [N]	Nominal current [A]	Travel [mm]	Speed [mm/s]	Cut-off	Connection	Dimensions LxHxD [mm]
ELTRAL S 24	24	1400	1.2	40-70 ^[1]	1.2	Limit stop	Connector plug for 2-core connecting cable	210x81.5x32.5

[1] Variably adjustable; preset to travel 50 mm = 200 mm opening width

Fanlight opening system VENTUS F200

ELTRAL S 24 / side installation

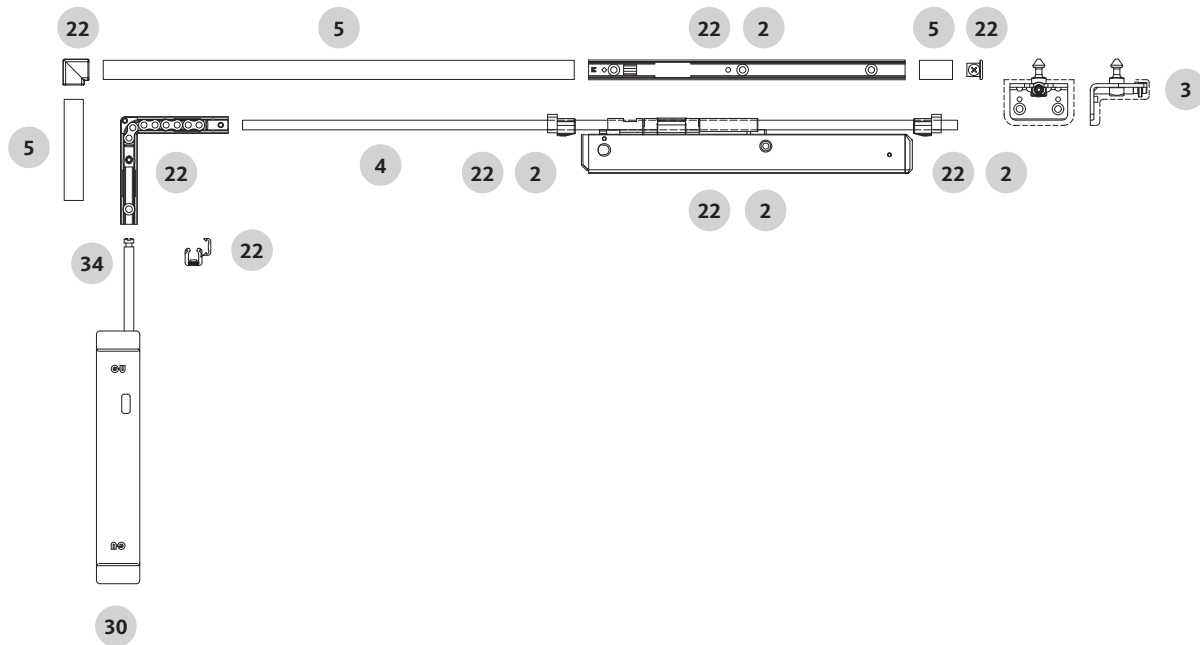

Fanlight opening system VENTUS F200

ELTRAL S 24 / side installation



Basic hardware set VENTUS F200

Item	Piece per pattern				Opening width [mm]	PU	Order number
	1	2n	3n	4n			
22	1	1	1	1	200	2	K-15012-00-0-1

Opening stay VENTUS F200

Item	Piece per pattern				Opening width [mm]	PU	Order number
	1	2n	3n	4n			
2	-	1	2	3	200	1	K-15013-00-0-1

Sash bracket VENTUS F200 [1]

Item	Piece per pattern				Overlap height [mm]	PU	Order number
	1	2n	3n	4n			
3	1	2	3	4	0-25	2	K-15225-00-0-1

Electrical drive ELTRAL S 24

Item	Piece per pattern				PU	Order number
	1	2n	3n	4n		
30	1	1	1	1	1	K-21020-00-0-1

Connecting parts ELTRAL S

Item	Piece per pattern				PU	Order number
	1	2n	3n	4n		
34	1	1	1	1	1	K-20181-00-0-1

Connecting rod and horizontal rod – Ø 8 mm

Item	Piece per pattern				Length [mm]	PU	Order number
	1	2n	3n	4n			
4	1	1	1	1	600	1	9-25476-06-0-1
					1850		9-25476-18-0-1
					3300		9-25476-33-0-1
					6000		9-25476-60-0-1

Cover profile

Item	Piece per pattern				Length [mm]	PU	Order number
	1	2n	3n	4n			
5	1	1	1	1	62	5	9-33444-01-0-1
					800		9-33444-06-0-1
					1800		9-33444-18-0-1
					3050		9-33444-33-0-1
					6000		9-33444-60-0-1

[1] Use insert according to the constitution of the profile.
 – Timber: 9-34508-00-0-0
 – PVC: 9-33105-00-0-1

Installation drawing 0-48801 / 0-43700

You will find further versions and finishes in Chapter Individual parts from page 334 and from page 390.

Fanlight opening system VENTUS F200

ELTRAL S 24 / side installation

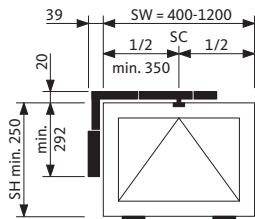

Pattern 1

Horizontal rod length depending on total sash width

Drive [1]	Total sash width dim. SW			
	700	800	1000	1200
Horizontal rod length	530	580	680	780

[1] ELTRAL S 24

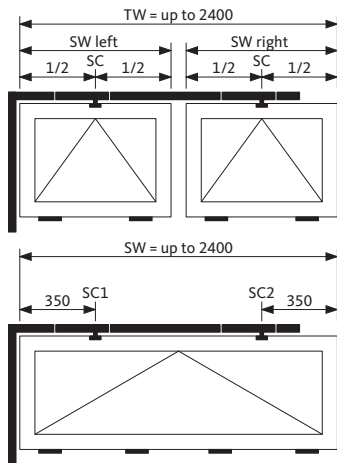

Pattern 2n

Horizontal rod length depending on total sash width

Drive [1]	Total sash width dim. SW or B					
	1400	1600	1800	2000	2200	2400
Horizontal rod length	1065	1265	1465	1665	1865	2065

[1] ELTRAL S 24

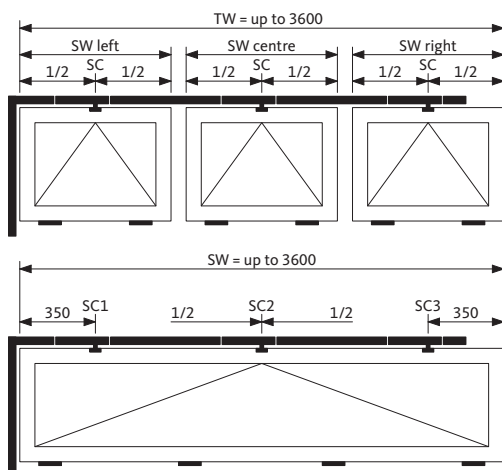

Pattern 3n

Horizontal rod length depending on total sash width

Drive [1]	Total sash width dim. SW or B					
	2600	2800	3000	3200	3400	3600
Horizontal rod length	2265	2465	2665	2865	3065	3265

[1] ELTRAL S 24

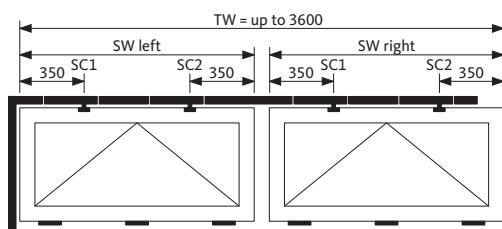

Pattern 4n

Horizontal rod length depending on total sash width

Drive [1]	Total sash width dim. SW or B					
	2600	2800	3000	3200	3400	3600
Horizontal rod length	2265	2465	2665	2865	3065	3265

[1] ELTRAL S 24

Fanlight opening system VENTUS F200

ELTRAL S 24 / side installation



Application ranges VENTUS F200 fanlight opener

with ELTRAL S 24

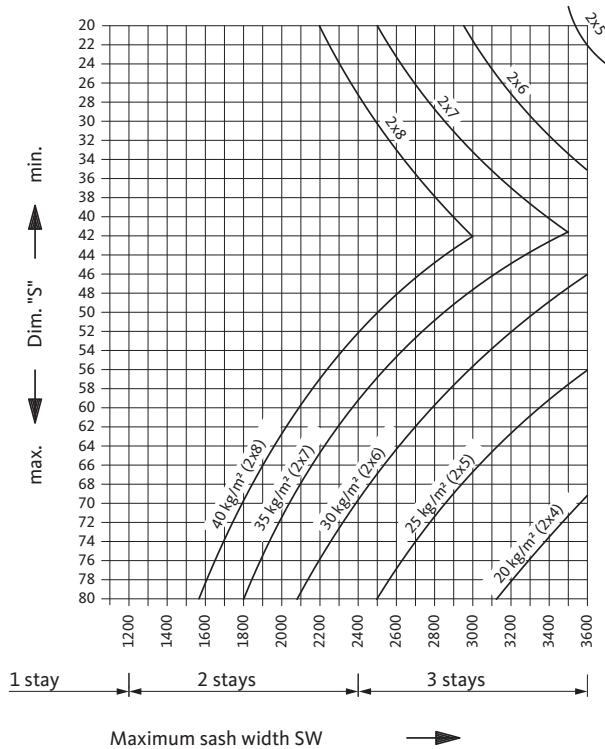

Dimension "S"

(= distance from sash centre of gravity to middle of hinge)

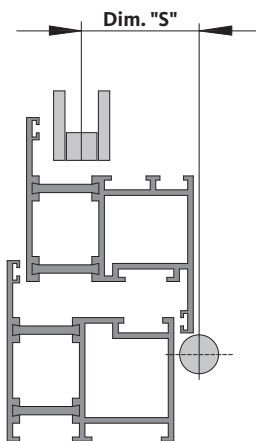

Calculation example with ELTRAL S 24

Example figures:

Glazing	2 x 8 mm
Weight of glass	40 kg/m ²
Sash width	1600 mm

Result:

Dimension "S"	20–79 mm possible
---------------	-------------------

Note: the overall sash weight must not exceed 80 kg.

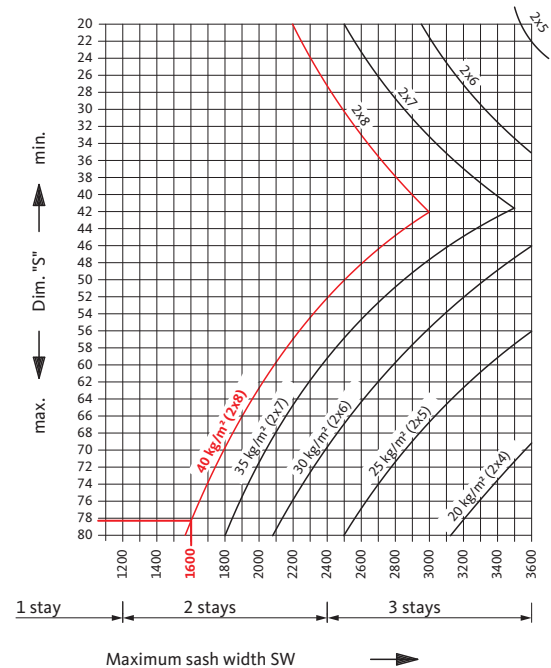

Fanlight opening system VENTUS F200

ELTRAL S 24 / top installation

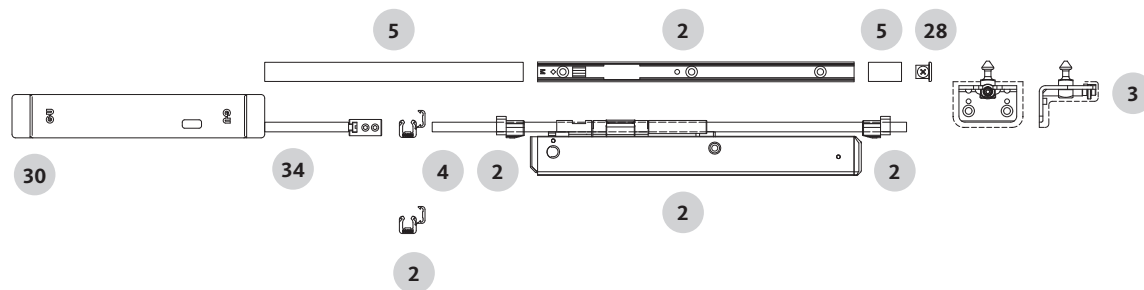

Fanlight opening system VENTUS F200

ELTRAL S 24 / top installation



Opening stay VENTUS F200

Item	Piece per pattern				Opening width [mm]	PU	Order number
	1	2n	3n	4n			
2	1	2	3	4	200	1	K-15013-00-0-1

End cap

Item	Piece per pattern				PU	Order number
	1	2n	3n	4n		
28	1	1	1	1	1	9-34412-00-0-6

Sash bracket VENTUS F200 [1]

Item	Piece per pattern				Overlap height [mm]	PU	Order number
	1	2n	3n	4n			
3	1	2	3	4	0-25	2	K-15225-00-0-1

Electrical drive ELTRAL S 24

Item	Piece per pattern				PU	Order number
	1	2n	3n	4n		
30	1	1	1	1	1	K-21020-00-0-1

Connecting parts ELTRAL S

Item	Piece per pattern				PU	Order number
	1	2n	3n	4n		
34	1	1	1	1	1	K-20181-00-0-1

Connecting rod and horizontal rod – Ø 8 mm

Item	Piece per pattern				Length [mm]	PU	Order number
	1	2n	3n	4n			
4	1	1	1	1	600	1	9-25476-06-0-1
					1850		9-25476-18-0-1
					3300		9-25476-33-0-1
					6000		9-25476-60-0-1

Cover profile

Item	Piece per pattern				Length [mm]	PU	Order number
	1	2n	3n	4n			
5	1	1	1	1	62	5	9-33444-01-0-1
					800		9-33444-06-0-1
					1800		9-33444-18-0-1
					3050		9-33444-33-0-1
					6000		9-33444-60-0-1

[1] Use insert according to the constitution of the profile.
 – Timber: 9-34508-00-0-0
 – PVC: 9-33105-00-0-1

Installation drawing 0-48801 / 0-43700

You will find further versions and finishes in Chapter Individual parts from page 334 and from page 390.

Fanlight opening system VENTUS F200

ELTRAL S 24 / top installation

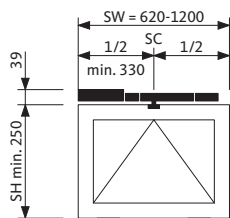

Pattern 1

Horizontal rod length depending on total sash width

Drive [1]	Total sash width dim. SW			
	700	800	1000	1200
Horizontal rod length	372	422	522	622

[1] ELTRAL S 24

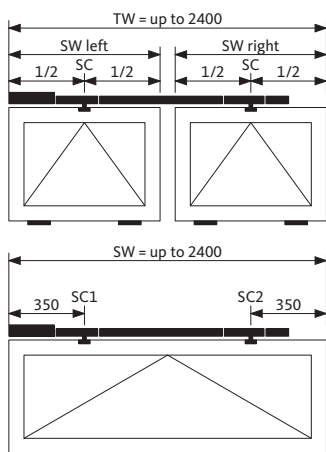

Pattern 2n

Horizontal rod length depending on total sash width

Drive [1]	Total sash width dim. SW or B					
	1400	1600	1800	2000	2200	2400
Horizontal rod length	1072	1272	1472	1672	1872	2072

[1] ELTRAL S 24

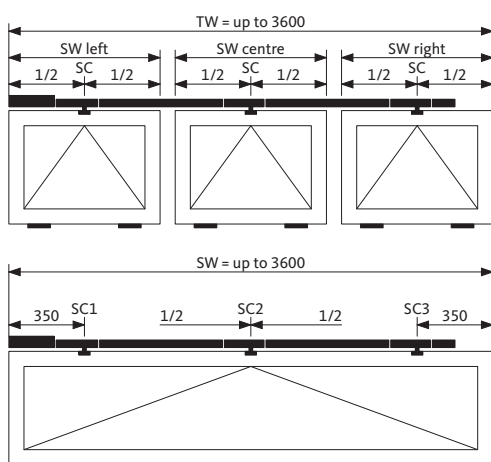

Pattern 3n

Horizontal rod length depending on total sash width

Drive [1]	Total sash width dim. SW or B					
	2600	2800	3000	3200	3400	3600
Horizontal rod length	2272	2472	2672	2872	3072	3272

[1] ELTRAL S 24

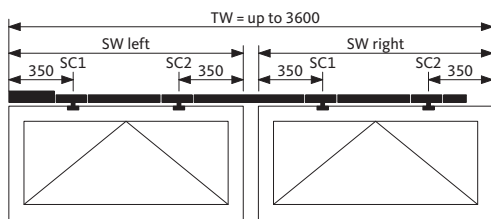

Pattern 4n

Horizontal rod length depending on total sash width

Drive [1]	Total sash width dim. SW or B					
	2600	2800	3000	3200	3400	3600
Horizontal rod length	2272	2472	2672	2872	3072	3272

[1] ELTRAL S 24

Fanlight opening system VENTUS F200

ELTRAL S 24 / top installation



Application ranges VENTUS F200 fanlight opener

with ELTRAL S 24

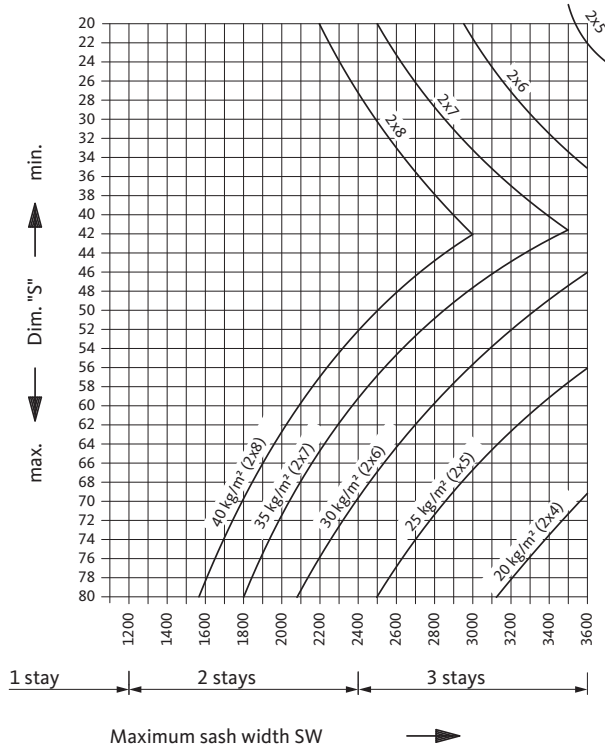

Dimension "S"

(= distance from sash centre of gravity to middle of hinge)

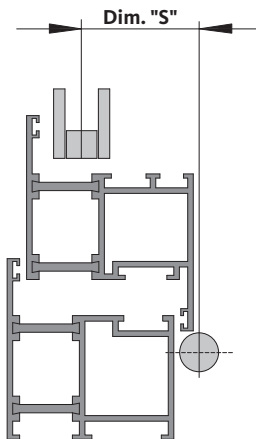

Calculation example with ELTRAL S 24

Example figures:

Glazing	2 x 8 mm
Weight of glass	40 kg/m ²
Sash width	1600 mm

Result:

Dimension "S"	20–79 mm possible
---------------	-------------------

Note: the overall sash weight must not exceed 80 kg.

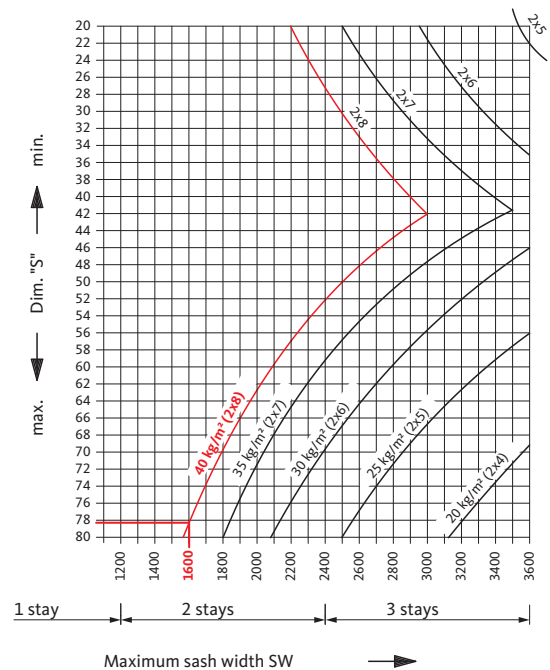

Fanlight opening system VENTUS F200

Individual parts - electrical drive

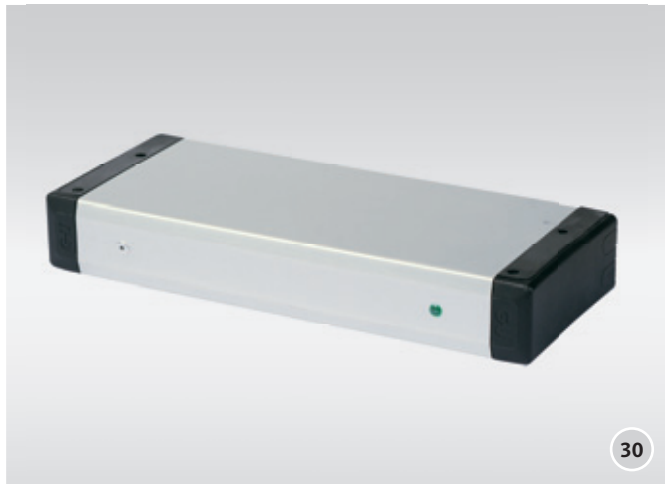



30

Electrical drive ELTRAL S 24

- Simple installation, horizontal or vertical (left/right)
- Adjustable travel for variable opening widths
- Limit stop
- Aluminium housing

Technical data	
Nominal voltage	24 V DC \pm 10 %
Nominal current	1.2 A
Pulling force	1400 N
Pushing force	1400 N
Travel	40–70 mm [1]
Travel speed	1.2 mm/s
Connection	Connector, 2-wire
Dimensions (D x H x L)	32.5 x 81.5 x 210 mm

Finish	PU	Order number
EV1, silver	1 pc	K-21020-00-0-1 
UC5 brown	1 pc	K-21020-00-0-5 
Traffic white (RAL 9016)	1 pc	K-21020-00-0-7 

[1] Variable adjustment possible. Preset to travel 50 mm = 200 mm opening width.

Fanlight opening system VENTUS F200

Individual parts - accessories

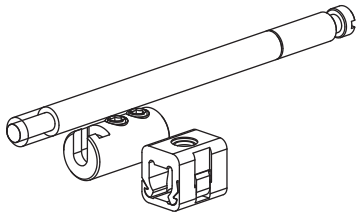

Connecting parts ELTRAL S

Integral parts

- Guide
- Coupling
- Rod

Finish	PU	Order number
ferGUard*silver	1 pc	K-20181-00-0-1
		

Fanlight opening system VENTUS F200

Electrical operation with electrical drive ELTRAL S 230



Rooms can be ventilated conveniently and cost-effectively with the fanlight opening system VENTUS F200 and the electrical drive ELTRAL.

Ideal for vertically installed, inwards and outward opening square Bottom-Hung, Top-Hung and pitched windows made of timber, PVC or metal.

The steplessly adjustable tilt position guarantees perfectly adjusted room ventilation.

The control of several sashes with just one drive opens up an additional potential for economic savings.

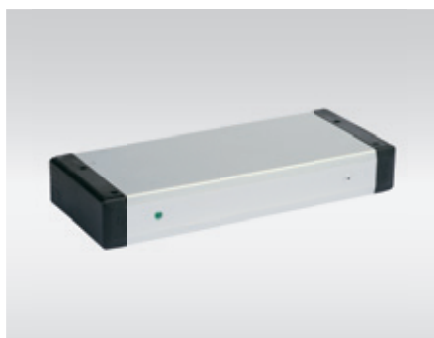

Powerful drive ELTRAL S 230

Advantages at a glance

- Additional saving potential by the control of several sash units via one drive
- Opening widths up to 200 mm, suitable for small sash heights from 300 mm
- Variable opening width setting



Fanlight opening system VENTUS F200

System features



System features

- Opening widths up to 200 mm for low sash heights from 300 mm
- Simple installation, horizontal or vertical (left/right)
- With position and function display
- Optional for increased security: operation of the concealed central locking system UNI-JET/ALU-JET via a dog
- Adjustable travel for variable opening widths
- Aluminium housing
- Individual or group control via ventilation push-button
- ELTRAL S electric drive also suitable for use at louvre windows
- Easy hinging and unhinging of the opening stay for quick window cleaning

Technical data

VENTUS F200 | Electrical operation with electrical drive ELTRAL S 230 | Bottom-Hung window

Drive	Max. sash width [mm]	Min. sash width [mm]		Min. sash height [mm]	Max. sash weight [kg]	Infill weight max. [kg/m ²]	Space required for drive [mm]	
		lateral	top				lateral	top
ELTRAL S 230	3600	410	630	300	80	40 ^[1]	39	39

[1] Depending on "dimension S" (= distance from sash centre of gravity to middle of hinge) and sash width

ELTRAL S 230 electric drives

Drive	Nominal voltage AC [V]	Nominal force [N]	Nominal current [A]	Travel [mm]	Speed [mm/s]	Cut-off	Connection	Dimensions LxHxD [mm]
ELTRAL S 230	230	1400	0.4	40-70 ^[1]	1.2	Limit stop	Connector plug for 4-core connecting cable	210x81.5x32.5

[1] Variably adjustable; preset to travel 50 mm = 200 mm opening width

Fanlight opening system VENTUS F200

ELTRAL S 230 / side installation

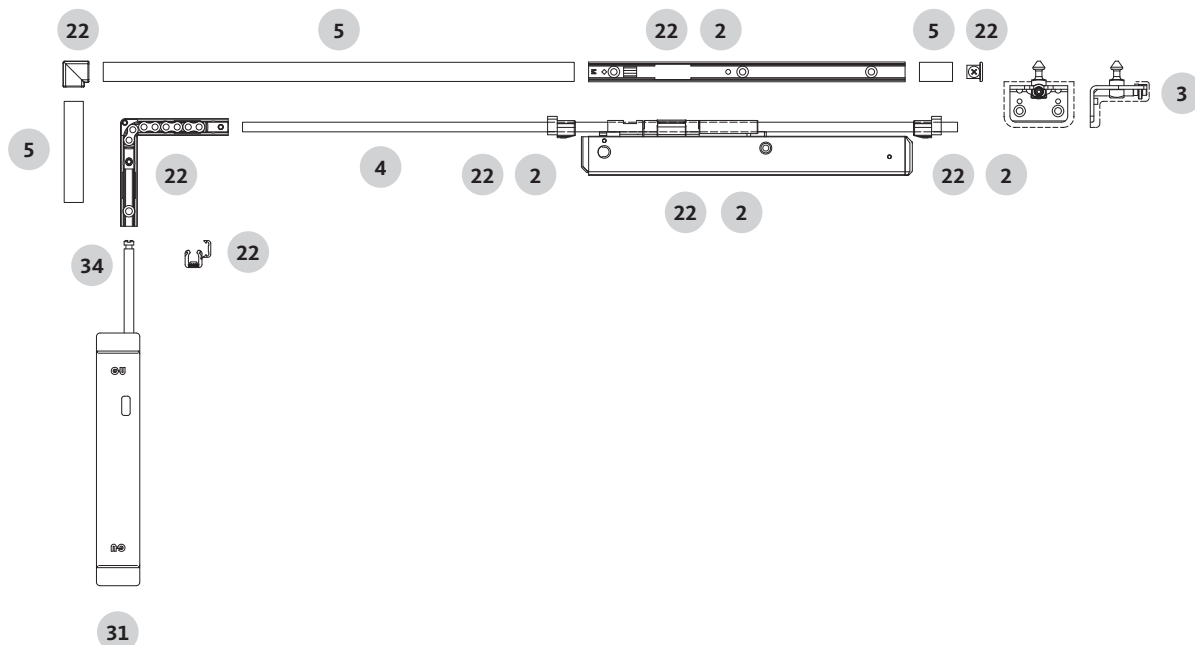

Fanlight opening system VENTUS F200

ELTRAL S 230 / side installation



Basic hardware set VENTUS F200

Item	Piece per pattern				Opening width [mm]	PU	Order number
	1	2n	3n	4n			
22	1	1	1	1	200	2	K-15012-00-0-1

Opening stay VENTUS F200

Item	Piece per pattern				Opening width [mm]	PU	Order number
	1	2n	3n	4n			
2	-	1	2	3	200	1	K-15013-00-0-1

Sash bracket VENTUS F200 [1]

Item	Piece per pattern				Overlap height [mm]	PU	Order number
	1	2n	3n	4n			
3	1	2	3	4	0-25	2	K-15225-00-0-1

Electrical drive ELTRAL S 230

Item	Piece per pattern				PU	Order number
	1	2n	3n	4n		
31	1	1	1	1	1	K-21021-00-0-1

Connecting parts ELTRAL S

Item	Piece per pattern				PU	Order number
	1	2n	3n	4n		
34	1	1	1	1	1	K-20181-00-0-1

Connecting rod and horizontal rod – Ø 8 mm

Item	Piece per pattern				Length [mm]	PU	Order number
	1	2n	3n	4n			
4	1	1	1	1	600	1	9-25476-06-0-1
					1850		9-25476-18-0-1
					3300		9-25476-33-0-1
					6000		9-25476-60-0-1

Cover profile

Item	Piece per pattern				Length [mm]	PU	Order number
	1	2n	3n	4n			
5	1	1	1	1	62	5	9-33444-01-0-1
					800		9-33444-06-0-1
					1800		9-33444-18-0-1
					3050		9-33444-33-0-1
					6000		9-33444-60-0-1

[1] Use insert according to the constitution of the profile.
 – Timber: 9-34508-00-0-0
 – PVC: 9-33105-00-0-1

Installation drawing 0-48801 / 0-43700

You will find further versions and finishes in Chapter Individual parts from page 346 and from page 390.

Fanlight opening system VENTUS F200

ELTRAL S 230 / side installation

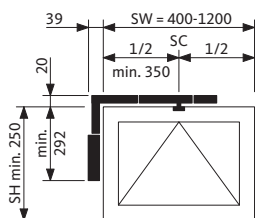

Pattern 1

Horizontal rod length depending on total sash width

Drive [1]	Total sash width dim. SW			
	700	800	1000	1200
Horizontal rod length	530	580	680	780

[1] ELTRAL S 230

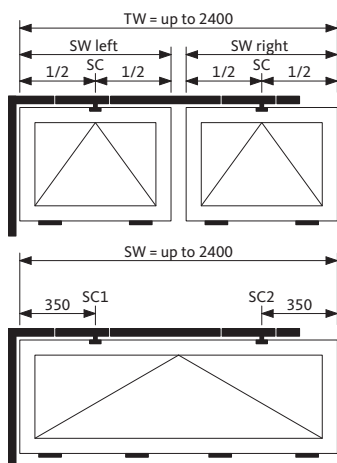

Pattern 2n

Horizontal rod length depending on total sash width

Drive [1]	Total sash width dim. SW or B					
	1400	1600	1800	2000	2200	2400
Horizontal rod length	1065	1265	1465	1665	1865	2065

[1] ELTRAL S 230

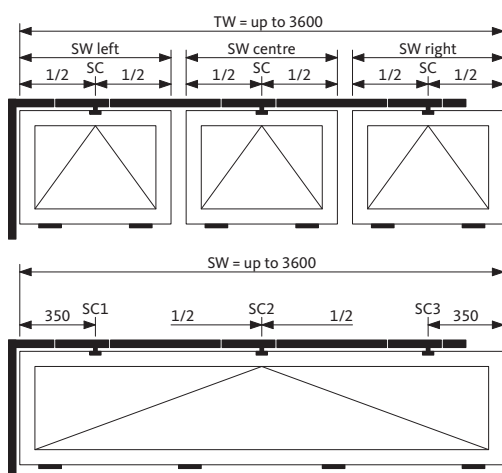

Pattern 3n

Horizontal rod length depending on total sash width

Drive [1]	Total sash width dim. SW or B					
	2600	2800	3000	3200	3400	3600
Horizontal rod length	2265	2465	2665	2865	3065	3265

[1] ELTRAL S 230

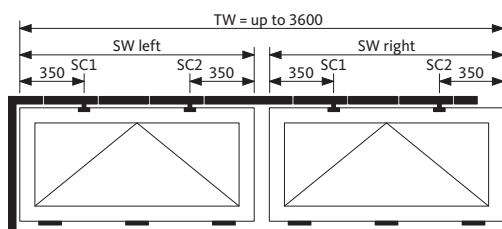

Pattern 4n

Horizontal rod length depending on total sash width

Drive [1]	Total sash width dim. SW or B					
	2600	2800	3000	3200	3400	3600
Horizontal rod length	2265	2465	2665	2865	3065	3265

[1] ELTRAL S 230

Fanlight opening system VENTUS F200

ELTRAL S 230 / side installation



Application ranges VENTUS F200 fanlight opener

with ELTRAL S 230

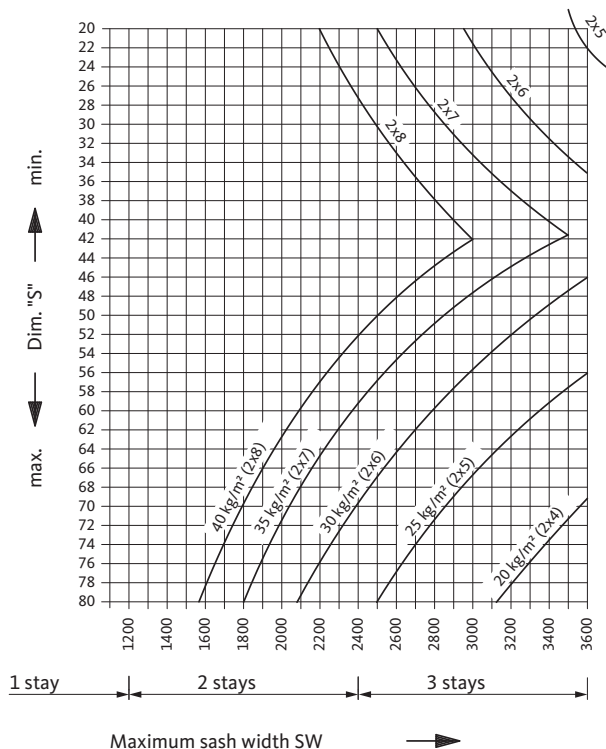

Dimension "S"

(= distance from sash centre of gravity to middle of hinge)

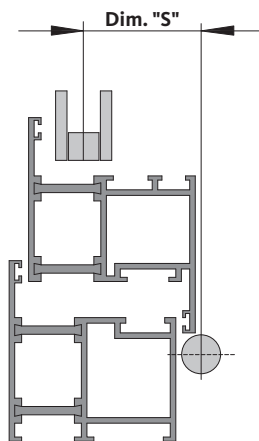

Calculation example with ELTRAL S 230

Example figures:

Glazing	2 x 8 mm
Weight of glass	40 kg/m ²
Sash width	1600 mm

Result:

Dimension "S"	20–79 mm possible
---------------	-------------------

Note: the overall sash weight must not exceed 80 kg.

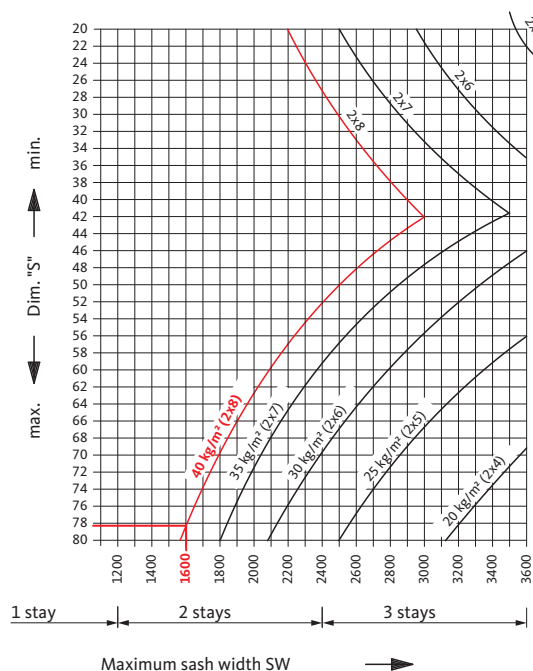

Fanlight opening system VENTUS F200

ELTRAL S 230 / top installation

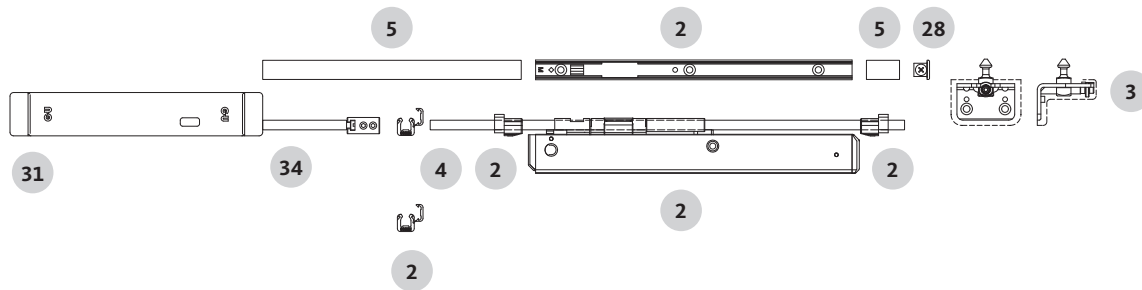

Fanlight opening system VENTUS F200

ELTRAL S 230 / top installation



Opening stay VENTUS F200

Item	Piece per pattern				Opening width [mm]	PU	Order number
	1	2n	3n	4n			
2	1	2	3	4	200	1	K-15013-00-0-1

End cap

Item	Piece per pattern				PU	Order number
	1	2n	3n	4n		
28	1	1	1	1	1	9-34412-00-0-6

Sash bracket VENTUS F200 [1]

Item	Piece per pattern				Overlap height [mm]	PU	Order number
	1	2n	3n	4n			
3	1	2	3	4	0-25	2	K-15225-00-0-1

Electrical drive ELTRAL S 230

Item	Piece per pattern				PU	Order number
	1	2n	3n	4n		
31	1	1	1	1	1	K-21021-00-0-1

Connecting parts ELTRAL S

Item	Piece per pattern				PU	Order number
	1	2n	3n	4n		
34	1	1	1	1	1	K-20181-00-0-1

Connecting rod and horizontal rod – Ø 8 mm

Item	Piece per pattern				Length [mm]	PU	Order number
	1	2n	3n	4n			
4	1	1	1	1	600	1	9-25476-06-0-1
					1850		9-25476-18-0-1
					3300		9-25476-33-0-1
					6000		9-25476-60-0-1

Cover profile

Item	Piece per pattern				Length [mm]	PU	Order number
	1	2n	3n	4n			
5	1	1	1	1	62	5	9-33444-01-0-1
					800		9-33444-06-0-1
					1800		9-33444-18-0-1
					3050		9-33444-33-0-1
					6000		9-33444-60-0-1

[1] Use insert according to the constitution of the profile.
 – Timber: 9-34508-00-0-0
 – PVC: 9-33105-00-0-1

Installation drawing 0-48801 / 0-43700

You will find further versions and finishes in Chapter Individual parts from page 346 and from page 390.

Fanlight opening system VENTUS F200

ELTRAL S 230 / top installation

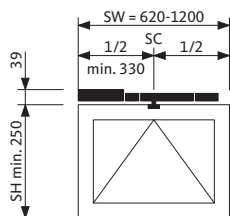

Pattern 1

Horizontal rod length depending on total sash width

Drive [1]	Total sash width dim. SW			
	700	800	1000	1200
Horizontal rod length	372	422	522	622

[1] ELTRAL S 230

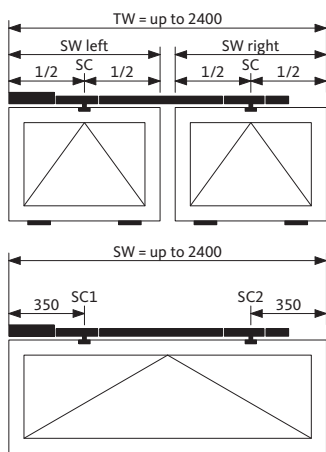

Pattern 2n

Horizontal rod length depending on total sash width

Drive [1]	Total sash width dim. SW or B					
	1400	1600	1800	2000	2200	2400
Horizontal rod length	1072	1272	1472	1672	1872	2072

[1] ELTRAL S 230

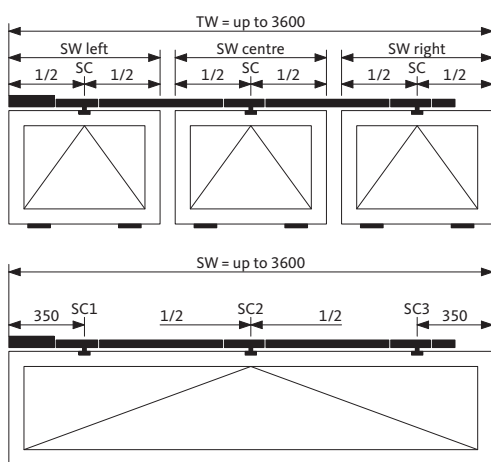

Pattern 3n

Horizontal rod length depending on total sash width

Drive [1]	Total sash width dim. SW or B					
	2600	2800	3000	3200	3400	3600
Horizontal rod length	2272	2472	2672	2872	3072	3272

[1] ELTRAL S 230

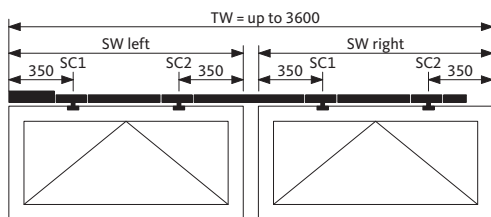

Pattern 4n

Horizontal rod length depending on total sash width

Drive [1]	Total sash width dim. SW or B					
	2600	2800	3000	3200	3400	3600
Horizontal rod length	2275	2475	2675	2875	3075	3275

[1] ELTRAL S 230

Fanlight opening system VENTUS F200

ELTRAL S 230 / top installation



Application ranges VENTUS F200 fanlight opener

with ELTRAL S 230

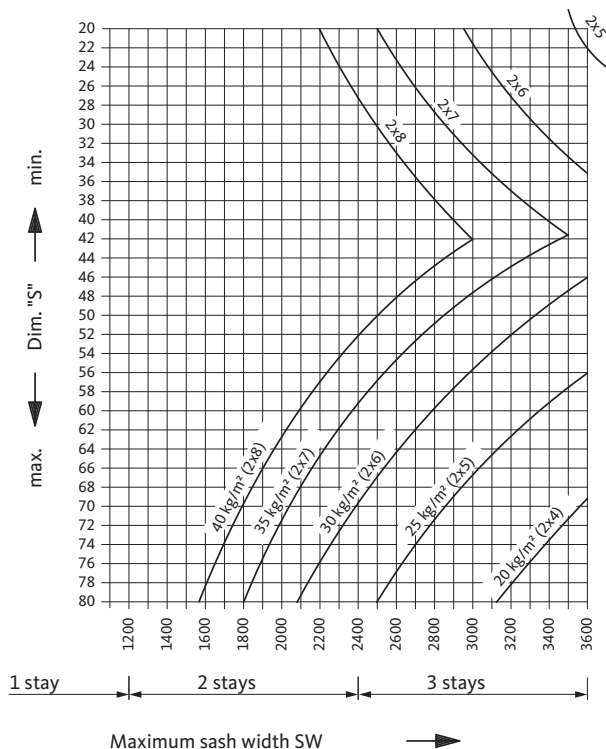

Dimension "S"

(= distance from sash centre of gravity to middle of hinge)

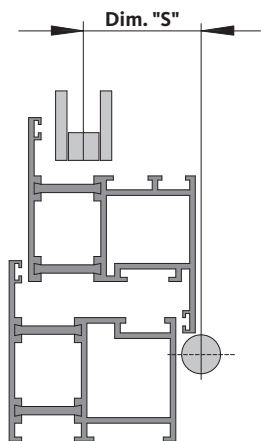

Calculation example with ELTRAL S 230

Example figures:

Glazing	2 x 8 mm
Weight of glass	40 kg/m ²
Sash width	1600 mm

Result:

Dimension "S"	20–79 mm possible
---------------	-------------------

Note: the overall sash weight must not exceed 80 kg.

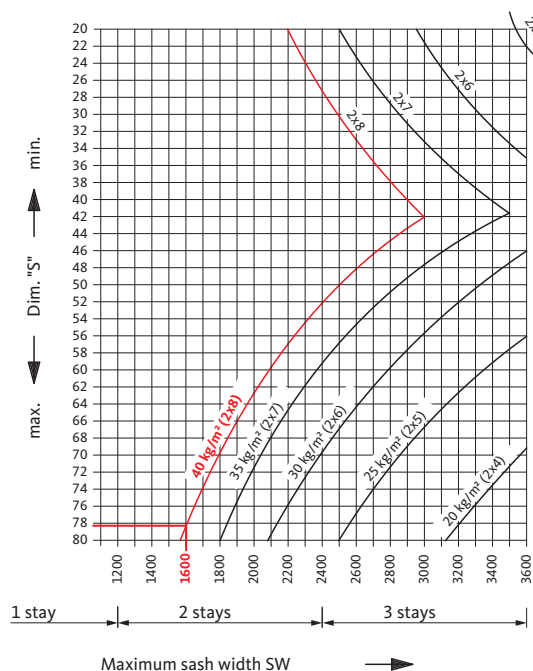

Fanlight opening system VENTUS F200

Individual parts - electrical drive

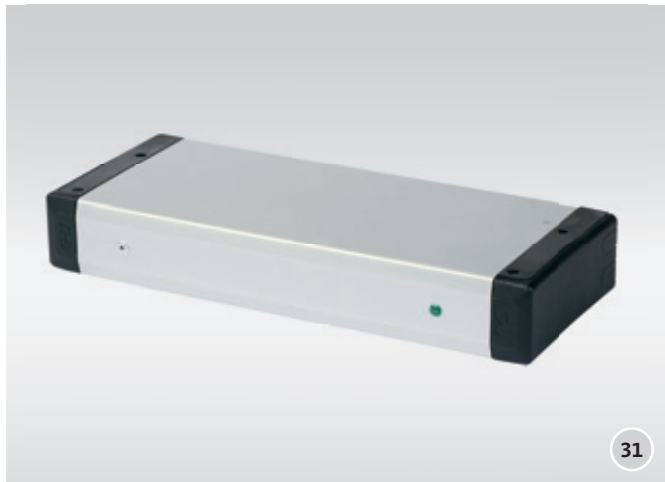



31

Electrical drive ELTRAL S 230

- Simple installation, horizontal or vertical (left/right)
- Adjustable travel for variable opening widths
- Limit stop
- Aluminium housing

Technical data	
Nominal voltage	230 V AC \pm 10 %
Nominal current	0.4 A
Pulling force	1400 N
Pushing force	1400 N
Travel	40–70 mm [1]
Travel speed	1.2 mm/s
Connection	Connector, 4-wire
Dimensions (D x H x L)	32.5 x 81.5 x 210 mm

Finish	PU	Order number
EV1, silver	1 pc	K-21021-00-0-1 
UC5 brown	1 pc	K-21021-00-0-5 
Traffic white (RAL 9016)	1 pc	K-21021-00-0-7 

[1] Variable adjustment possible. Preset to travel 50 mm = 200 mm opening width.

Fanlight opening system VENTUS F200

Individual parts - accessories

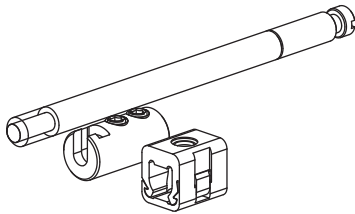

Connecting parts ELTRAL S

Integral parts

- Guide
- Coupling
- Rod

Finish	PU	Order number
ferGUard*silver	1 pc	K-20181-00-0-1

Complete test cable for ELTRAL S 230 electric drives

	PU	Order number
	1 pc	6-26338-00-0-0

Fanlight opening system VENTUS F200

Manual operation via hand lever or crank



The manual fanlight opening system VENTUS F200 from the Gretsch-Unitas group allows the opening and closing of a wide range of window shapes – regardless of whether these are square Bottom-Hung windows, round or segmental arch, pitched or triangular windows.

Also, window projections and reveals are mastered with ease. Steplessly adjustable tilt positions guarantee perfectly controlled room ventilation and permit large opening widths.



Automatic locking in the stay

Advantages at a glance

- Flat fanlight opening stay for vertically installed Bottom-Hung windows of different shapes 
- Cost-efficient control of several sashes using a vertical or corner drive-gear with crank
- Ideally suited for windows offering limited mounting space
- The stay can be easily hinged and unhinged, e.g. for window cleaning

Fanlight opening system VENTUS F200

System features



System features

- Intensive room ventilation because of large opening widths of up to 200 mm
- Ideally suited for small sash heights from 250 mm
- Suitable for sash weights of up to 80 kg
- Compact modules for fast and easy mounting
- Steplessly controllable sash brackets for overlap heights of 0–25 mm
- A wide range of operation possibilities: hand lever, vertical or corner drive-gear with crank, transmissions (transom-mullion transmission / flexible transmission)
- Flat-form fanlight opening stay for vertically installed timber, PVC or metal Bottom-Hung windows
- Individually adapted tilt position by reducing the opening widths
- Drilling jigs for all application ranges
- No visible fixing screws
- The internal locking device inside the stay ensures maximum surface pressure on the window, thereby meeting today's requirements for water tightness, acoustic insulation and energy savings

One system – many applications

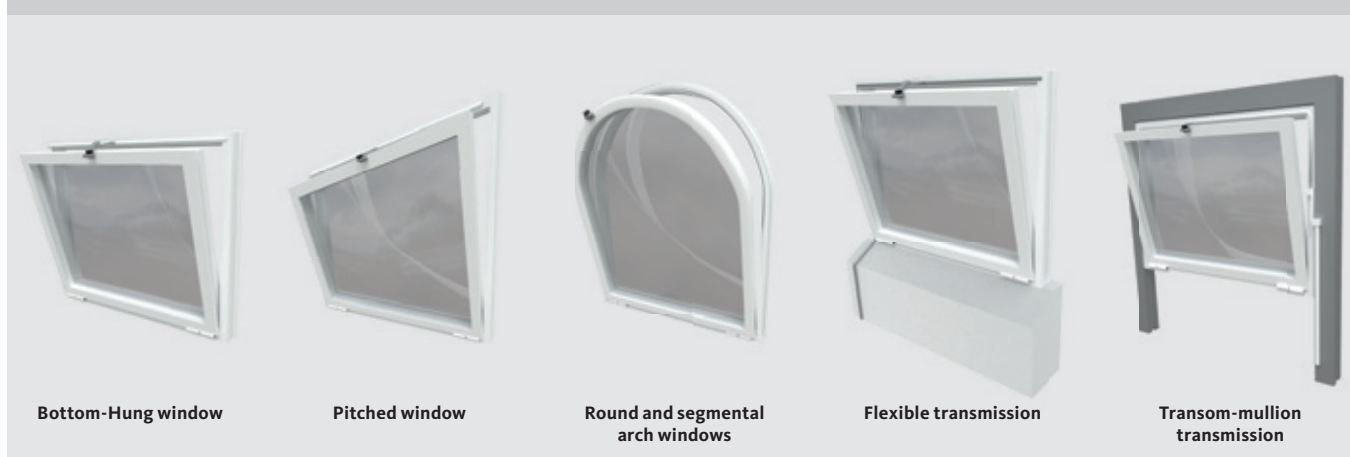

Bottom-Hung window

Pitched window

Round and segmental arch windows

Flexible transmission

Transom-mullion transmission

Fanlight opening system VENTUS F200

System design



System design

The GU VENTUS fanlight opening system consists of:

- 1 Opening stay F200
- 2 Sash bracket for attachment to the sash
- 3 Corner-drive for force transmission
- 4 Connecting rods and rod guides
- 5 Cover profiles
- 6 Hand-lever for opening and closing

Alternative: operation via crank with vertical or corner drive-gear

- 7 Additional restrictor and cleaning stays, e.g. EURO-SOLID



Opening stay VENTUS F200



High gasket pressure thanks to adjustable angular sash bracket



Lockable hand lever / standard hand lever



Crank

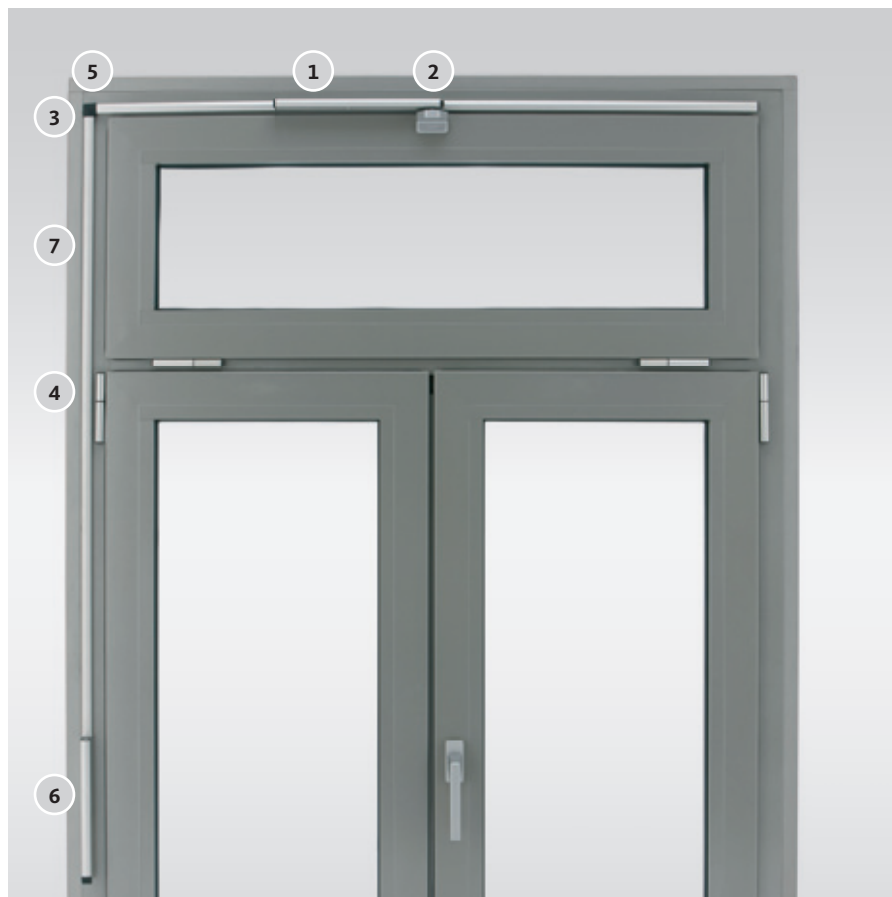

Fanlight opening system VENTUS F200

Special solutions, technical data



Special solutions

Top-Hung window, outward-opening

Completely pre-mounted stay unit for all outward-opening Top-Hung windows with opening widths up to 200 mm.



Additional locks

Additional surface-mounted, vertical locking elements for secure side sealing for high Bottom-Hung windows.

Optional locking via dog in combination with the concealed JET central locking system. This provides a visually appealing solution for greater security and increased burglar inhibition.



EURO-SOLID restrictor and cleaning stay

The RAL directives stipulate: Bottom-Hung sashes must be equipped with restrictor stays in addition to the fanlight hardware.

EURO-SOLID restrictor and cleaning stays prevent damage that might arise from incorrect attachment of the opening stays. Moreover, they provide great convenience when cleaning as the sash is held in the desired position.



Technical data

VENTUS F200 | Operation with hand lever or crank | Bottom-Hung windows

Door hardware	Sash width [mm]	Min. sash height [mm]	Opening width [mm]	Max. sash weight [kg]	Travel [mm]	Space requirement [mm]	
						lateral	top
VENTUS F200 [1]	400-3600 400-3600	300 250	200 165	80	50 40	20	20

[1] For overlap heights 0-25 mm

Fanlight opening system VENTUS F200

Hand lever

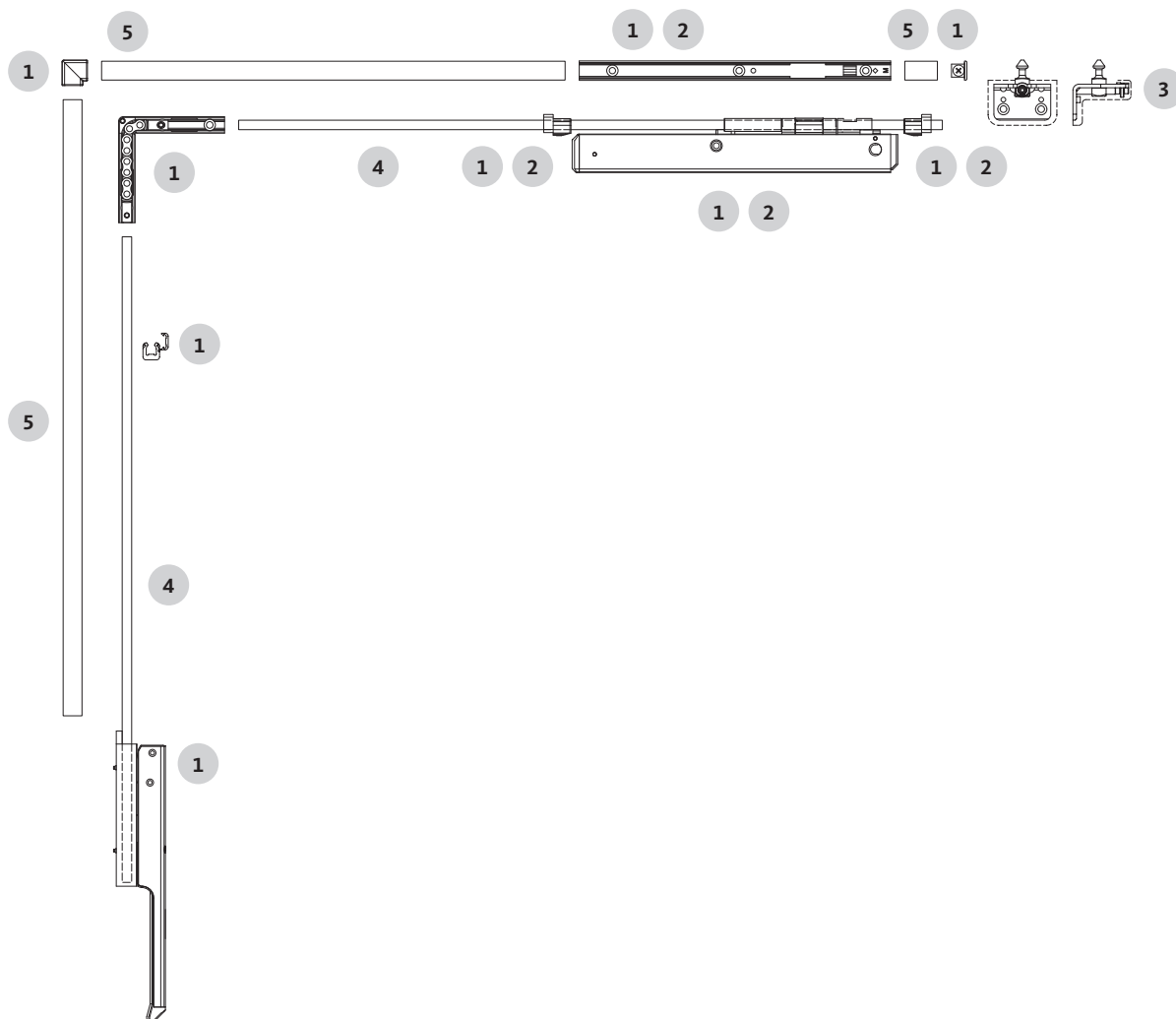

Fanlight opening system VENTUS F200

Hand lever



Basic hardware set VENTUS F200

Item	Piece per pattern				Opening width [mm]	PU	Order number
	1	2n	3n	4n			
1	1	1	1	1	200	2	K-15011-00-0-1

Opening stay VENTUS F200

Item	Piece per pattern				Opening width [mm]	PU	Order number
	1	2n	3n	4n			
2	-	1	2	3	200	1	K-15013-00-0-1

Sash bracket VENTUS F200 [1]

Item	Piece per pattern				Overlap height [mm]	PU	Order number
	1	2n	3n	4n			
3	1	2	3	4	0-25	2	K-15225-00-0-1

Connecting rod and horizontal rod – Ø 8 mm

Item	Piece per pattern				Length [mm]	PU	Order number
	1	2n	3n	4n			
4	1	1	1	1	1850	1	9-25476-18-0-1
					3300		9-25476-33-0-1
					6000		9-25476-60-0-1

Cover profile

Item	Piece per pattern				Length [mm]	PU	Order number
	1	2n	3n	4n			
5	1	1	1	1	62	5	9-33444-01-0-1
					1800		9-33444-18-0-1
					3050		9-33444-33-0-1
					6000		9-33444-60-0-1

[1] Use insert according to the constitution of the profile.
 – Timber: 9-34508-00-0-0
 – PVC: 9-33105-00-0-1

Installation drawing 0-43700

You will find further versions and finishes in Chapter Individual parts from page 390.

Fanlight opening system VENTUS F200

Hand lever / bell-shaped angle transmission

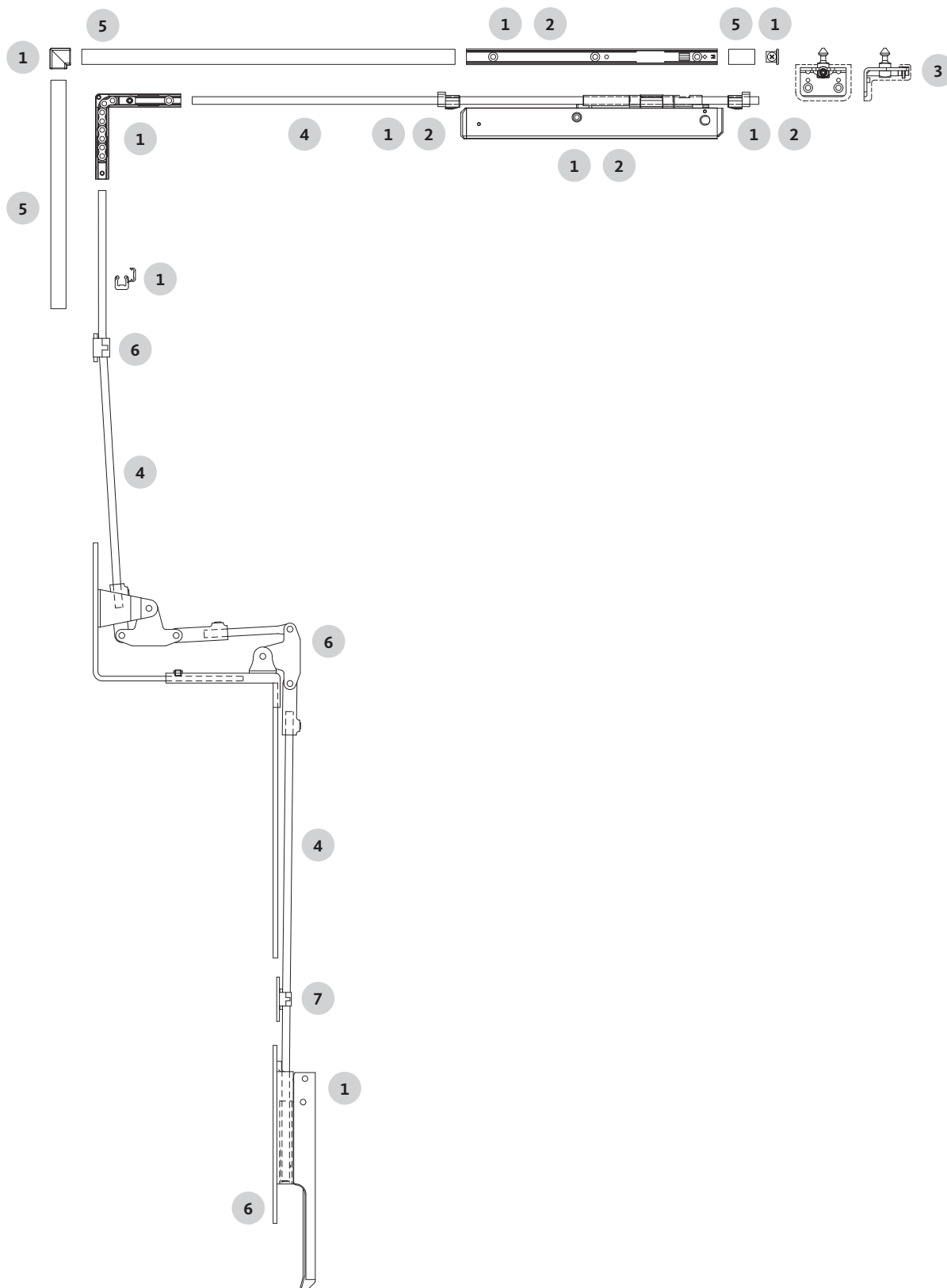

Fanlight opening system VENTUS F200

Hand lever / bell-shaped angle transmission



Basic hardware set VENTUS F200

Item	Piece per pattern				Opening width [mm]	PU	Order number
	1	2n	3n	4n			
1	1	1	1	-	200	2	K-15011-00-0-1

Opening stay VENTUS F200

Item	Piece per pattern				Opening width [mm]	PU	Order number
	1	2n	3n	4n			
2	-	1	2	-	200	1	K-15013-00-0-1

Sash bracket VENTUS F200 [1]

Item	Piece per pattern				Overlap height [mm]	PU	Order number
	1	2n	3n	4n			
3	1	2	3	-	0-25	2	K-15225-00-0-1

Bell-shaped angle transmission

Item	Piece per pattern				PU	Order number
	1	2n	3n	4n		
6	1	1	1	-	1	K-13730-00-0-1

Guide for bell-shaped angle transmission

Item	Piece per pattern				B-E [mm]	PU	Order number
	1	2n	3n	4n			
7	1	1	1	-	901-1800	1	K-13731-00-0-1
	2	2	2	-	1501-2100		

Connecting rod and horizontal rod – Ø 8 mm

Item	Piece per pattern				Length [mm]	PU	Order number
	1	2n	3n	4n			
4	1	1	1	-	600	1	9-25476-06-0-1
					1850		9-25476-18-0-1
					3300		9-25476-33-0-1
					6000		9-25476-60-0-1

Cover profile

Item	Piece per pattern				Length [mm]	PU	Order number
	1	2n	3n	4n			
5	1	1	1	-	62	5	9-33444-01-0-1
					800		9-33444-06-0-1
					1800		9-33444-18-0-1
					3050		9-33444-33-0-1
					6000		9-33444-60-0-1

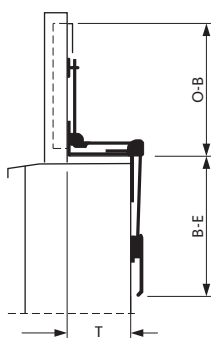

O-B min.	B-E min.	T
350	470	150-405

6 7

[1] Use insert according to the constitution of the profile.
 – Timber: 9-34508-00-0-0
 – PVC: 9-33105-00-0-1

Installation drawing 0-43700

You will find further versions and finishes in Chapter Individual parts from page 390.

Fanlight opening system VENTUS F200

Hand lever / rod transmission

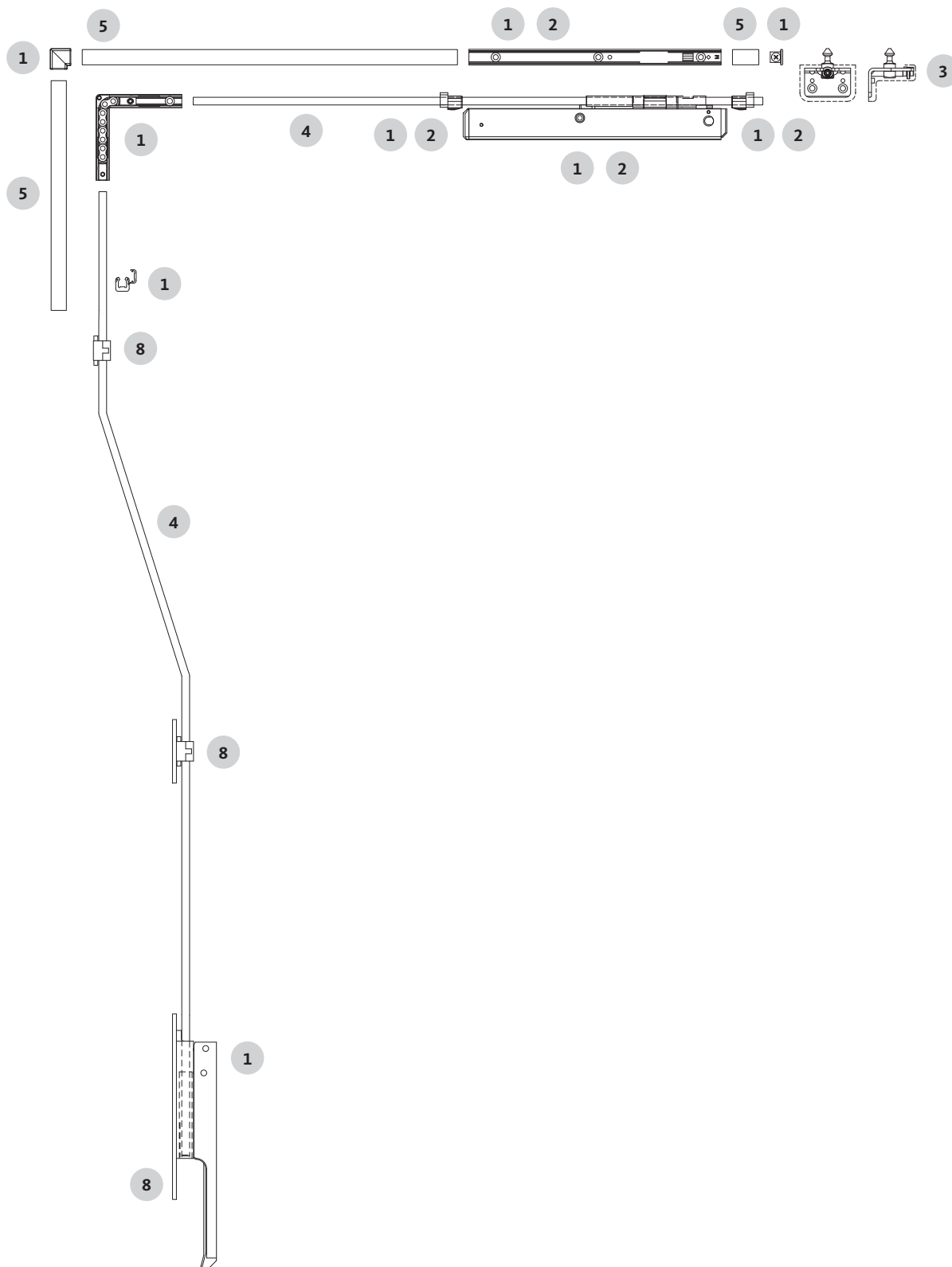

Fanlight opening system VENTUS F200

Hand lever / rod transmission



Basic hardware set VENTUS F200

Item	Piece per pattern				Opening width [mm]	PU	Order number
	1	2n	3n	4n			
1	1	1	1	-	200	2	K-15011-00-0-1

Opening stay VENTUS F200

Item	Piece per pattern				Opening width [mm]	PU	Order number
	1	2n	3n	4n			
2	-	1	2	-	200	1	K-15013-00-0-1

Sash bracket VENTUS F200 [1]

Item	Piece per pattern				Overlap height [mm]	PU	Order number
	1	2n	3n	4n			
3	1	2	3	-	0-25	2	K-15225-00-0-1

Additional parts for connecting rod transmission Ø 8 mm [2]

Item	Piece per pattern				PU	Order number
	1	2n	3n	4n		
8	1	1	1	-	1	K-13732-00-0-1

Connecting rod and horizontal rod – Ø 8 mm

Item	Piece per pattern				Length [mm]	PU	Order number
	1	2n	3n	4n			
4	1	1	1	-	600	1	9-25476-06-0-1
					1850		9-25476-18-0-1
					3300		9-25476-33-0-1
					6000		9-25476-60-0-1

Cover profile

Item	Piece per pattern				Length [mm]	PU	Order number
	1	2n	3n	4n			
5	1	1	1	-	62	5	9-33444-01-0-1
					800		9-33444-06-0-1
					1800		9-33444-18-0-1
					3050		9-33444-33-0-1
					6000		9-33444-60-0-1

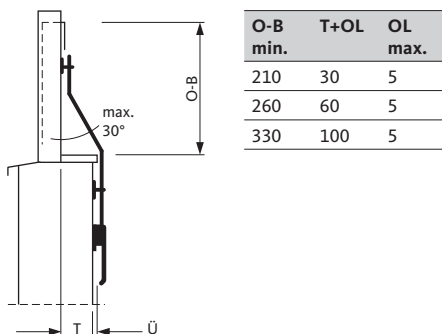

8

[1] Use insert according to the constitution of the profile.
 – Timber: 9-34508-00-0-0
 – PVC: 9-33105-00-0-1

[2] The cropping of the connecting rod is to be provided by customer.

Installation drawing 0-43700

You will find further versions and finishes in Chapter Individual parts from page 390.

Fanlight opening system VENTUS F200

Hand lever / flexible transmission

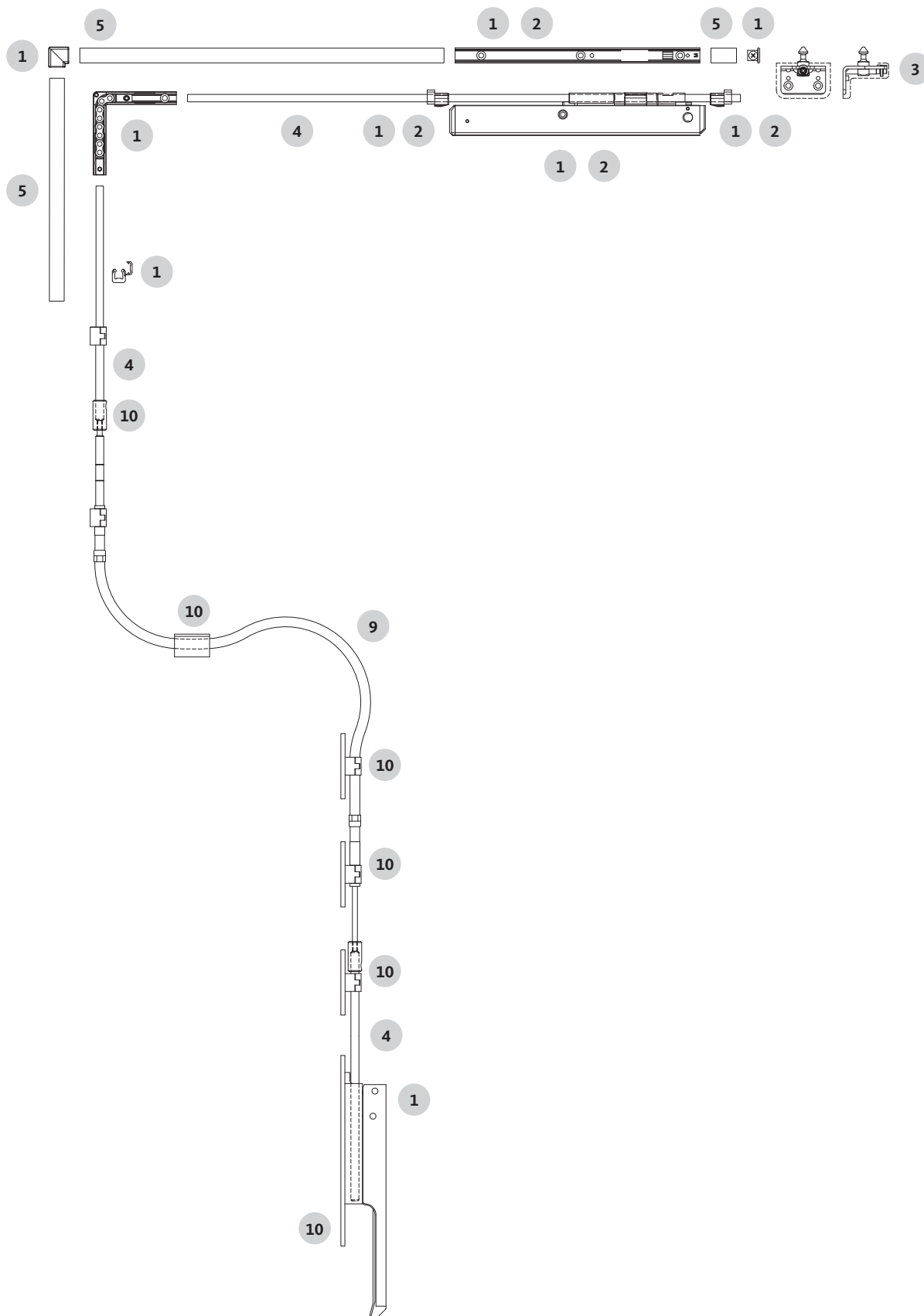

Fanlight opening system VENTUS F200

Hand lever / flexible transmission



Basic hardware set VENTUS F200

Item	Piece per pattern				Opening width [mm]	PU	Order number
	1	2n	3n	4n			
1	1	1	1	-	200	2	K-15011-00-0-1

Opening stay VENTUS F200

Item	Piece per pattern				Opening width [mm]	PU	Order number
	1	2n	3n	4n			
2	-	1	2	-	200	1	K-15013-00-0-1

Sash bracket VENTUS F200 [1]

Item	Piece per pattern				Overlap height [mm]	PU	Order number
	1	2n	3n	4n			
3	1	2	3	-	0-25	2	K-15225-00-0-1

Flexible transmission

Item	Piece per pattern				Length [mm]	PU	Order number
	1	2n	3n	4n			
9	1	1	1	-	200	1	6-29495-02-0-1
					400		6-29495-04-0-1
					700		6-29495-07-0-1
					1000		6-29495-10-0-1
					1300		6-29495-13-0-1
					2000		6-29495-20-0-1

Accessories for flexible transmission

Item	Piece per pattern				PU	Order number
	1	2n	3n	4n		
10	1	1	1	-	1	K-14312-00-0-1

Connecting rod and horizontal rod – Ø 8 mm

Item	Piece per pattern				Length [mm]	PU	Order number
	1	2n	3n	4n			
4	1	1	1	-	600	1	9-25476-06-0-1
					1850		9-25476-18-0-1
					3300		9-25476-33-0-1
					6000		9-25476-60-0-1

Cover profile

Item	Piece per pattern				Length [mm]	PU	Order number
	1	2n	3n	4n			
5	1	1	1	-	62	5	9-33444-01-0-1
					800		9-33444-06-0-1
					1800		9-33444-18-0-1
					3050		9-33444-33-0-1
					6000		9-33444-60-0-1

[1] Use insert according to the constitution of the profile.
 – Timber: 9-34508-00-0-0
 – PVC: 9-33105-00-0-1

Installation drawing 0-43700

You will find further versions and finishes in Chapter Individual parts from page 390.

Fanlight opening system VENTUS F200

Hand lever / flexible transmission

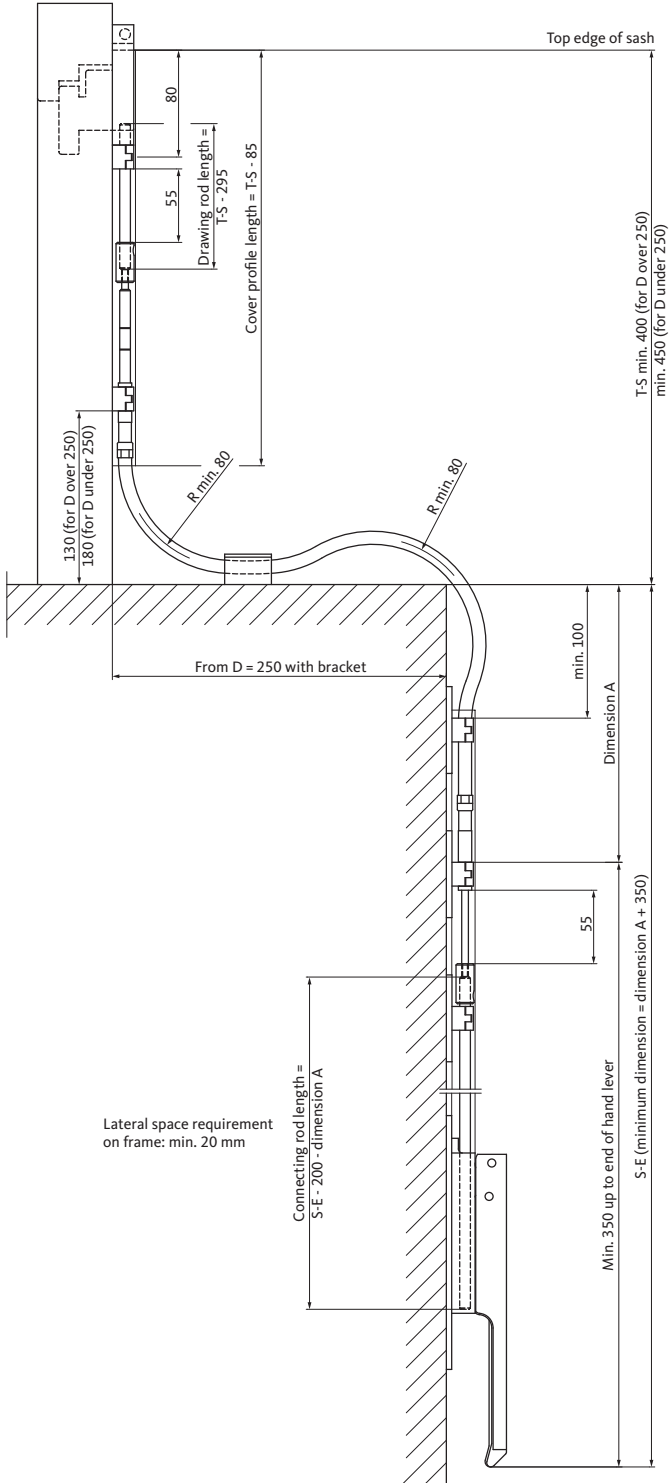

Fanlight opening system VENTUS F200

Flexible transmission – minimum dimensions according to recess depth

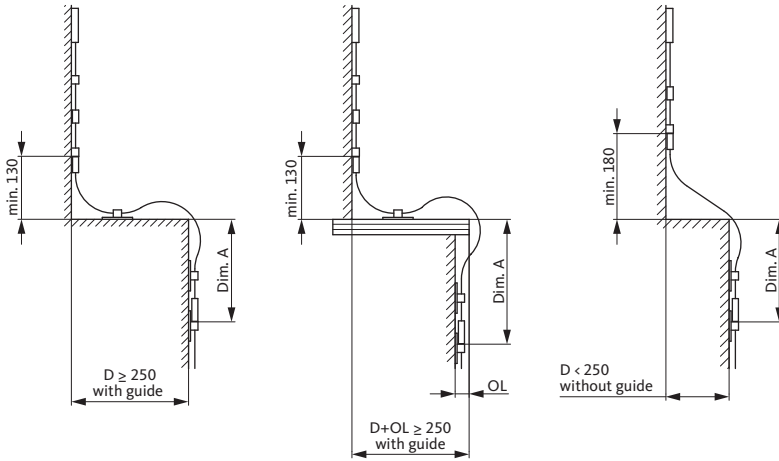

Dim. T	Dim. A
730	170
700	200
670	230
640	260
610	290
580	320
550	350
520	380
490	410
460	440
Length 1000	
430	170
400	200
370	230
340	260
310	290
280	320
250	350
Length 700	
Dimension T ≥ 250 mm with guide	

Dim. T+OL	Dim. A
670	230
640	260
610	290
580	320
550	350
520	380
490	410
460	440
Length 1000	
430	170
400	200
370	230
340	260
310	290
280	320
250	350
Length 700	
Dimension OL max. 40 mm	
Dimension T+OL ≥ 250 mm with guide	

Dim. T	Dim. A
240	360
210	380
180	400
150	425
120	450
Length 700	
90	170
60	190
30	200
0	220
Length 400	
Dimension T < 250 mm without guide	

Fanlight opening system VENTUS F200

Hand lever / transom / mullion transmission

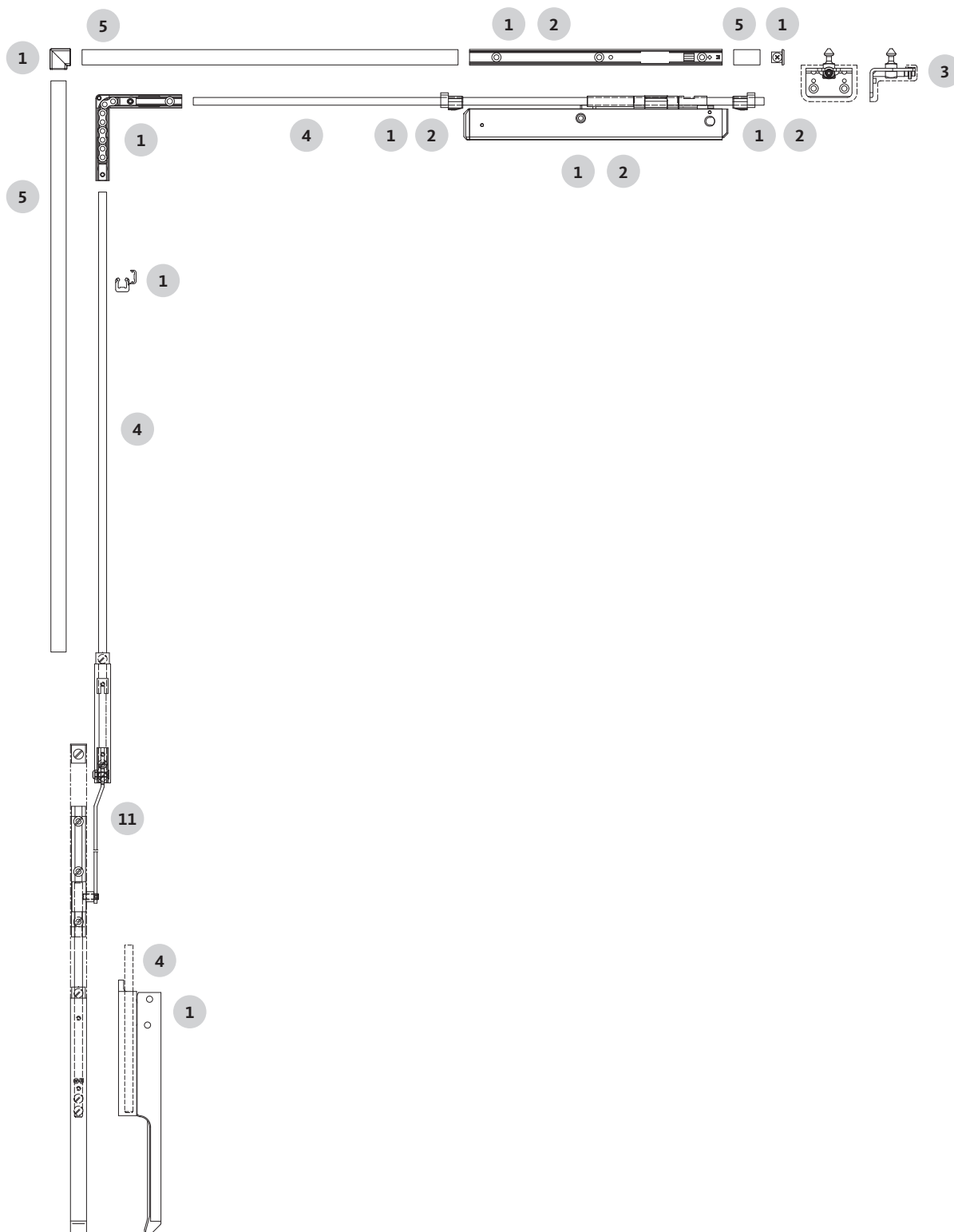

Fanlight opening system VENTUS F200

Hand lever / transom / mullion transmission



Basic hardware set VENTUS F200

Item	Piece per pattern				Opening width [mm]	PU	Order number
	1	2n	3n	4n			
1	1	1	1	-	200	2	K-15011-00-0-1

Opening stay VENTUS F200

Item	Piece per pattern				Opening width [mm]	PU	Order number
	1	2n	3n	4n			
2	-	1	2	-	200	1	K-15013-00-0-1

Sash bracket VENTUS F200 [1]

Item	Piece per pattern				Overlap height [mm]	PU	Order number
	1	2n	3n	4n			
3	1	2	3	-	0-25	2	K-15225-00-0-1

Transom / mullion transmission

Item	Piece per pattern				Mullion depth T [mm]	Rod length L [mm]	PU	Order number
	1	2n	3n	4n				
11	1	1	1	-	17-80	126	1	K-15384-08-0-1
	1	1	1	-	17-150	266	1	K-15384-15-0-1

Connecting rod and horizontal rod – Ø 8 mm

Item	Piece per pattern				Length [mm]	PU	Order number
	1	2n	3n	4n			
4	1	1	1	-	600	1	9-25476-06-0-1
					1850		9-25476-18-0-1
					3300		9-25476-33-0-1
					6000		9-25476-60-0-1

Cover profile

Item	Piece per pattern				Length [mm]	PU	Order number
	1	2n	3n	4n			
5	1	1	1	-	62	5	9-33444-01-0-1
					800		9-33444-06-0-1
					1800		9-33444-18-0-1
					3050		9-33444-33-0-1
					6000		9-33444-60-0-1



11

[1] Use insert according to the constitution of the profile.
 – Timber: 9-34508-00-0-0
 – PVC: 9-33105-00-0-1

Installation drawing 0-43889 / 0-44206 / 0-43700

You will find further versions and finishes in Chapter Individual parts from page 390.

Fanlight opening system VENTUS F200

Hand lever / T angle bracket

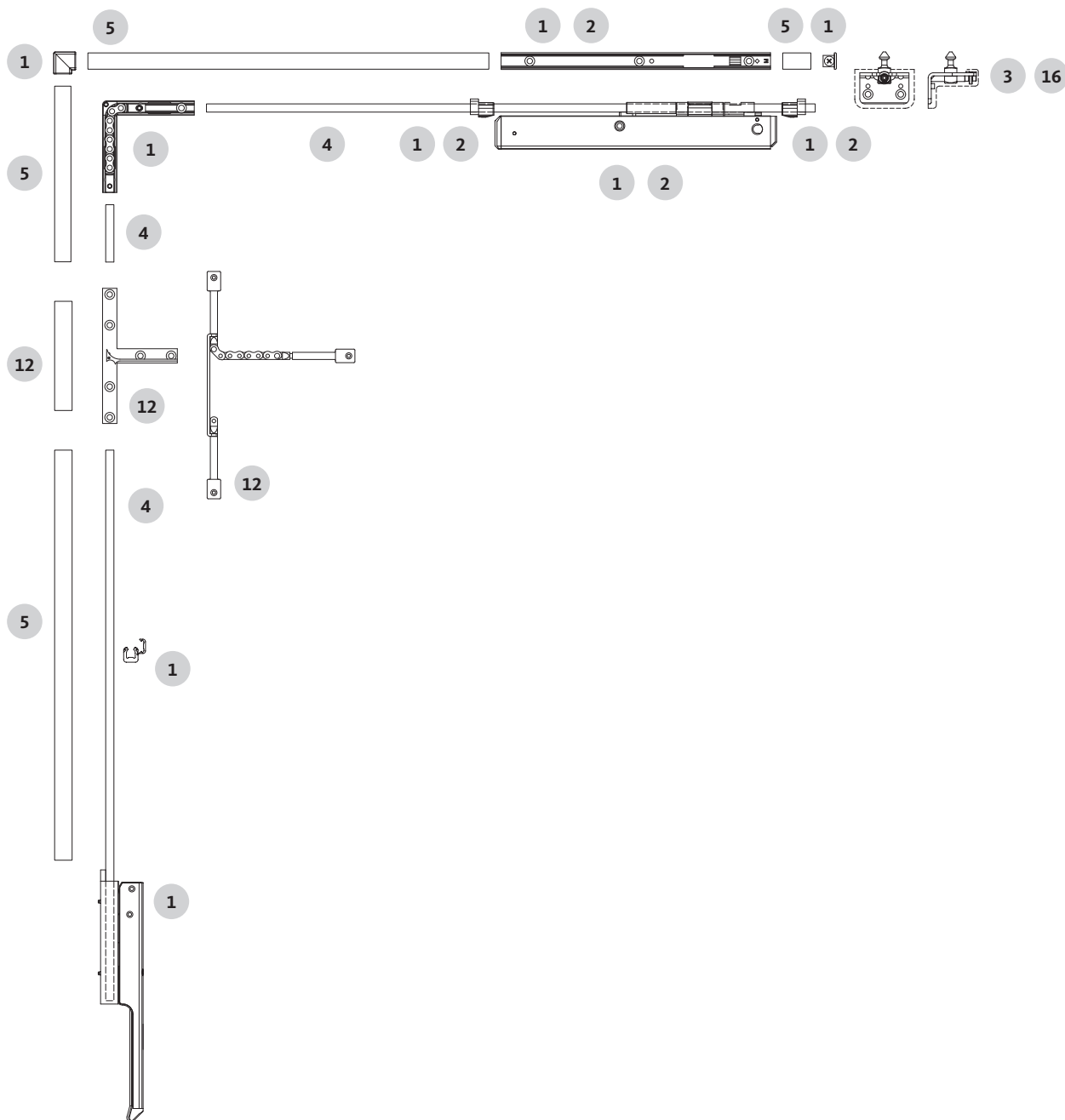

Fanlight opening system VENTUS F200

Hand lever / T angle bracket



Basic hardware set VENTUS F200

Item	Piece per pattern				Opening width [mm]	PU	Order number
	1	2n	3n	4n			
1	-	1	-	-	200	2	K-15011-00-0-1

Opening stay VENTUS F200

Item	Piece per pattern				Opening width [mm]	PU	Order number
	1	2n	3n	4n			
2	-	1	-	-	200	1	K-15013-00-0-1

Sash bracket VENTUS F200 [1]

Item	Piece per pattern				Overlap height [mm]	PU	Order number
	1	2n	3n	4n			
3	-	2	-	-	0-25	2	K-15225-00-0-1

Sash bracket VENTUS F200 with joint

Item	Piece per pattern				Overlap height [mm]	PU	Order number
	1	2n	3n	4n			
16	-	2	-	-	0-25	1	K-15507-00-0-1

T-angle bracket VENTUS F200

Item	Piece per pattern				PU	Order number
	1	2n	3n	4n		
12	-	1	-	-	1	K-14194-00-0-1

Applications

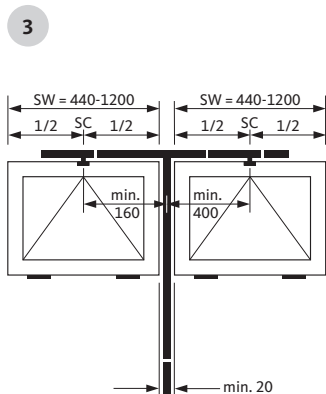

Window arrangement 2n (side-by-side)

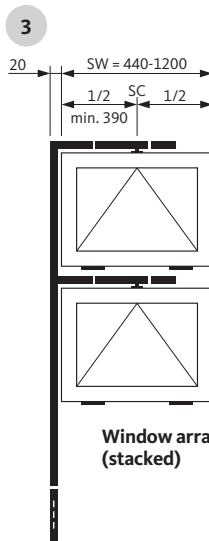

Window arrangement 2ü (stacked)

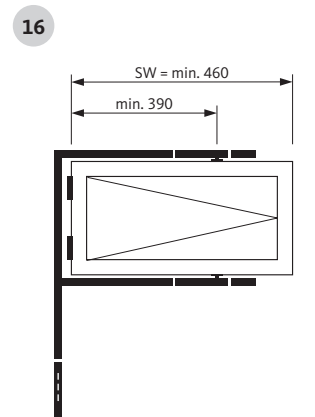

Side-Hung window with 2 stays

Connecting rod and horizontal rod – Ø 8 mm

Item	Piece per pattern				Length [mm]	PU	Order number
	1	2n	3n	4n			
4	-	1	-	-	1850	1	9-25476-18-0-1
					3300		9-25476-33-0-1
					6000		9-25476-60-0-1

Cover profile

Item	Piece per pattern				Length [mm]	PU	Order number
	1	2n	3n	4n			
5	-	1	-	-	62	5	9-33444-01-0-1
					1800		9-33444-18-0-1
					3050		9-33444-33-0-1
					6000		9-33444-60-0-1

[1] Use insert according to the constitution of the profile.
 - Timber: 9-34508-00-0-0
 - PVC: 9-33105-00-0-1

Installation drawing 0-43822 / 0-43700

You will find further versions and finishes in Chapter Individual parts from page 390.

Fanlight opening system VENTUS F200

Hand lever / vertical additional lock

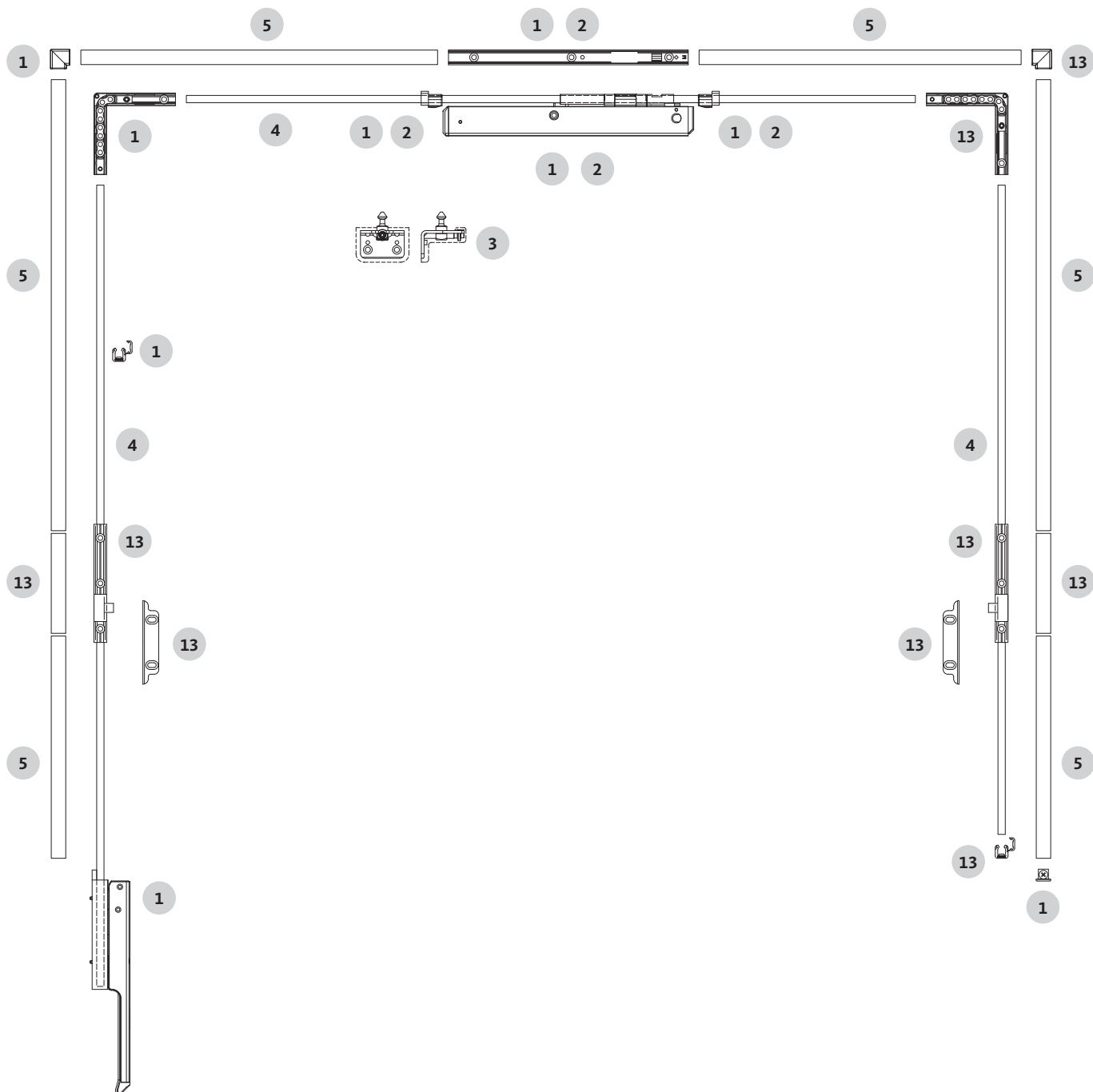

Fanlight opening system VENTUS F200

Hand lever / vertical additional lock



Basic hardware set VENTUS F200

Item	Piece per pattern				Opening width [mm]	PU	Order number
	1	2n	3n	4n			
1	1	1	1	-	200	2	K-15011-00-0-1

Opening stay VENTUS F200

Item	Piece per pattern				Opening width [mm]	PU	Order number
	1	2n	3n	4n			
2	-	1	2	-	200	1	K-15013-00-0-1

Sash bracket VENTUS F200 [1]

Item	Piece per pattern				Overlap height [mm]	PU	Order number
	1	2n	3n	4n			
3	1	2	3	-	0-25	2	K-15225-00-0-1

Additional lock VENTUS F200 vertical

Item	Piece per pattern				Description	Overlap height [mm]	SW min. [mm]	SH min. [mm]	PU	Order number
	1	2n	3n	4n						
13	1	1	1	-	For timber/PVC windows with sash overlap	from 16	458	400	1	K-15209-00-0-1
					For metal windows with sash overlap	6-7			1	K-15210-60-0-1
						7-8			1	K-15210-70-0-1
						8-9			1	K-15210-80-0-1
						9-10			1	K-15210-90-0-1
					For metal/timber windows flush-mounted	-			1	K-15210-01-0-1

Connecting rod and horizontal rod – Ø 8 mm

Item	Piece per pattern				Length [mm]	PU	Order number
	1	2n	3n	4n			
4	1	1	1	-	1850	1	9-25476-18-0-1
					3300		9-25476-33-0-1
					6000		9-25476-60-0-1

Cover profile

Item	Piece per pattern				Length [mm]	PU	Order number
	1	2n	3n	4n			
5	1	1	1	-	1800	5	9-33444-18-0-1
					3050		9-33444-33-0-1
					6000		9-33444-60-0-1

[1] Use insert according to the constitution of the profile.
 – Timber: 9-34508-00-0-0
 – PVC: 9-33105-00-0-1

Installation drawing 0-43800 / 0-43700

You will find further versions and finishes in Chapter Individual parts from page 390.

Fanlight opening system VENTUS F200

Hand lever / round and segmental arch windows – pattern 1

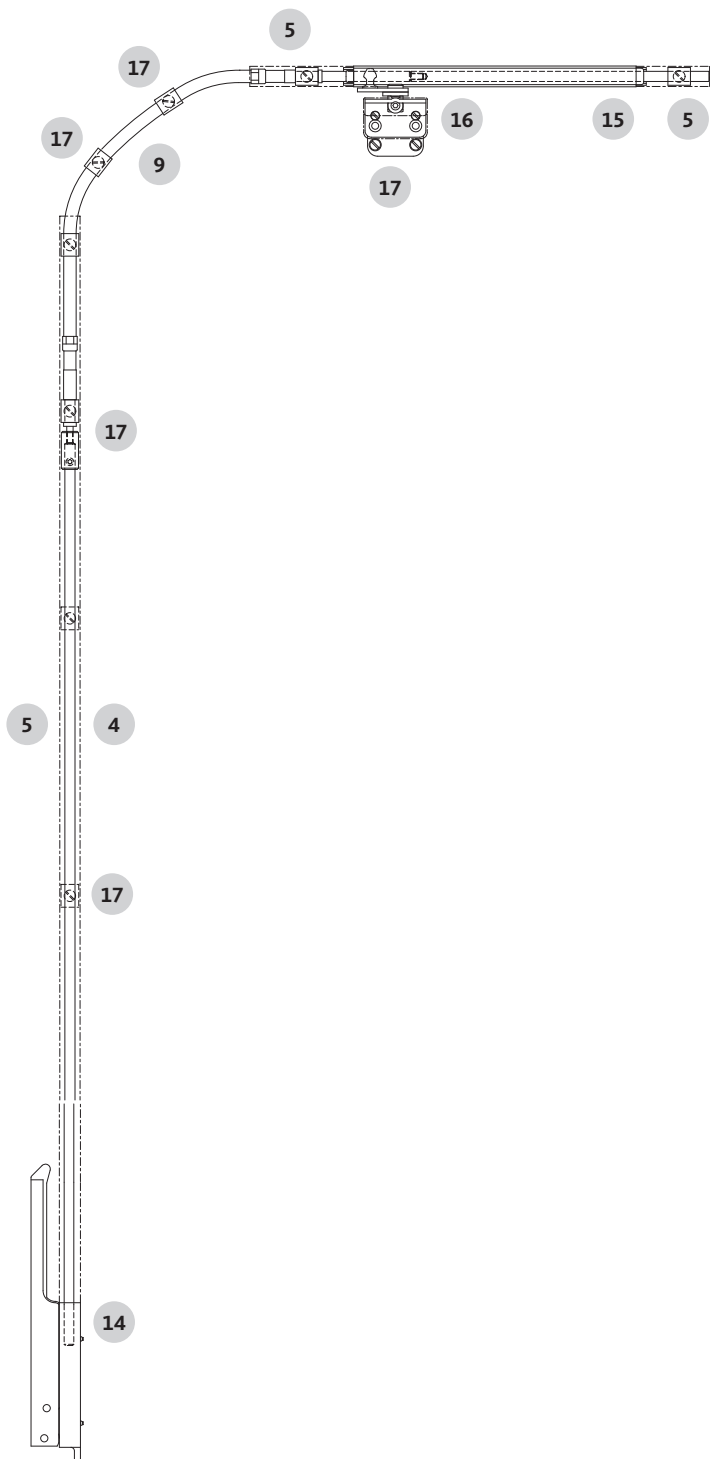

Fanlight opening system VENTUS F200

Hand lever / round and segmental arch windows – pattern 1



Hand lever VENTUS F200

Item	Piece per pattern				Travel [mm]	PU	Order number
	1	2n	3n	4n			
14	1	-	-	-	50	1	6-28681-50-0-1

Opening stay VENTUS F200 short

Item	Piece per pattern				Opening width [mm]	PU	Order number
	1	2n	3n	4n			
15	1	-	-	-	150	1	K-15483-00-0-1

Sash bracket VENTUS F200 with joint

Item	Piece per pattern				Overlap height [mm]	PU	Order number
	1	2n	3n	4n			
16	1	-	-	-	0-25	1	K-15507-00-0-1

Accessories for round and segmental arch windows

Item	Piece per pattern				PU	Order number
	1	2n	3n	4n		
17	1	-	-	-	1	K-15484-00-0-1

Flexible transmission for round arch windows

Item	Piece per pattern				SW [mm]	Length [mm]	PU	Order number
	1	2n	3n	4n				
9	1	-	-	-	500-900	700	1	6-29495-07-0-1
					901-1300	1000		6-29495-10-0-1

Flexible transmission for segmental arch windows

Item	Piece per pattern				SW [mm]	Length [mm]	PU	Order number
	1	2n	3n	4n				
9	1	-	-	-	500-600	400	1	6-29495-04-0-1
					601-900	700		6-29495-07-0-1
					901-1300	1000		6-29495-10-0-1

Connecting rod and horizontal rod – Ø 8 mm

Item	Piece per pattern				Length [mm]	PU	Order number
	1	2n	3n	4n			
4	1	-	-	-	600	1	9-25476-06-0-1
					1850		9-25476-18-0-1
					3300		9-25476-33-0-1
					6000		9-25476-60-0-1

Cover profile

Item	Piece per pattern				Length [mm]	PU	Order number
	1	2n	3n	4n			
5	1	-	-	-	800	5	9-33444-06-0-1
					1800		9-33444-18-0-1
					3050		9-33444-33-0-1
					6000		9-33444-60-0-1

Installation drawing 0-43951

You will find further versions and finishes in Chapter Individual parts from page 390.

Fanlight opening system VENTUS F200

Hand lever / round and segmental arch windows – pattern 2n

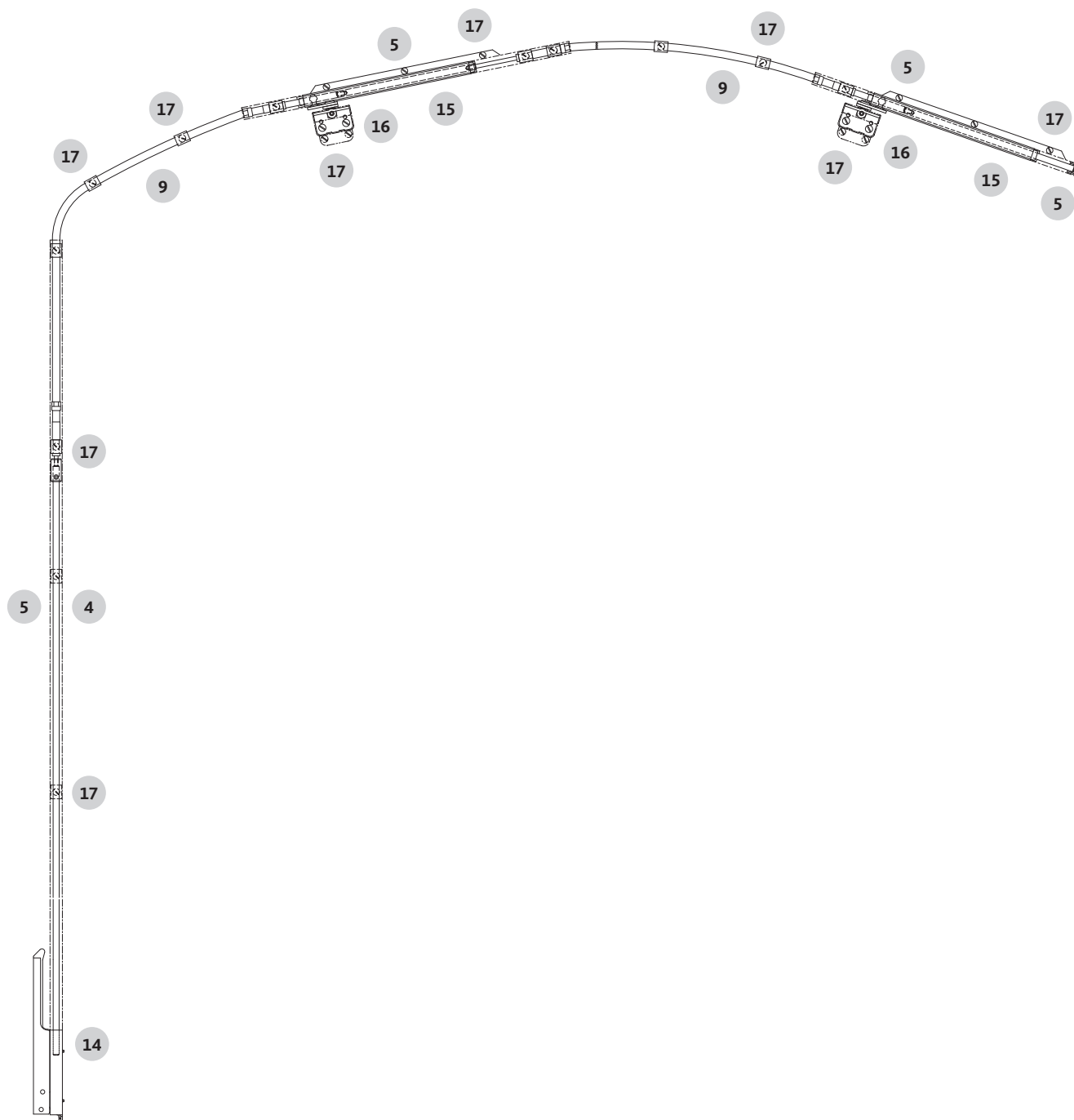

Fanlight opening system VENTUS F200

Hand lever / round and segmental arch windows – pattern 2n



Hand lever VENTUS F200

Item	Piece per pattern				Travel [mm]	PU	Order number
	1	2n	3n	4n			
14	-	1	-	-	50	1	6-28681-50-0-1

Opening stay VENTUS F200 short

Item	Piece per pattern				Opening width [mm]	PU	Order number
	1	2n	3n	4n			
15	-	2	-	-	150	1	K-15483-00-0-1

Sash bracket VENTUS F200 with joint

Item	Piece per pattern				Overlap height [mm]	PU	Order number
	1	2n	3n	4n			
16	-	2	-	-	0-25	1	K-15507-00-0-1

Accessories for round and segmental arch windows

Item	Piece per pattern				PU	Order number
	1	2n	3n	4n		
17	-	1	-	-	1	K-15484-00-0-1
	-	1	-	-	1	K-15485-00-0-1

Flexible transmission for round arch windows

Hand lever – stay

Item	Piece per pattern				SW [mm]	Length [mm]	PU	Order number
	1	2n	3n	4n				
9	-	1	-	-	1300-2100	1000	1	6-29495-10-0-1
	-	1	-	-	2101-2400	1300	1	6-29495-13-0-1

Stay – stay

Item	Piece per pattern				SW [mm]	Length [mm]	PU	Order number
	1	2n	3n	4n				
9	-	1	-	-	1300-1700	400	1	6-29495-04-0-1
	-	1	-	-	1701-1900	700	1	6-29495-07-0-1
	-	1	-	-	1901-2400	1000	1	6-29495-10-0-1

Flexible transmission for segmental arch windows

Hand lever – stay

Item	Piece per pattern				SW [mm]	Length [mm]	PU	Order number
	1	2n	3n	4n				
9	-	1	-	-	1200-2400	700	1	6-29495-07-0-1

Stay – stay

Item	Piece per pattern				SW [mm]	Length [mm]	PU	Order number
	1	2n	3n	4n				
9	-	1	-	-	1200-1500	400	1	6-29495-04-0-1
	-	1	-	-	1501-1800	700	1	6-29495-07-0-1
	-	1	-	-	1801-2100	1000	1	6-29495-10-0-1
	-	1	-	-	2101-2400	1300	1	6-29495-13-0-1

Connecting rod and horizontal rod – Ø 8 mm

Item	Piece per pattern				Length [mm]	PU	Order number
	1	2n	3n	4n			
4	-	1	-	-	600	1	9-25476-06-0-1
	-	1	-	-	1850	1	9-25476-18-0-1
	-	1	-	-	3300	1	9-25476-33-0-1
	-	1	-	-	6000	1	9-25476-60-0-1

Cover profile

Item	Piece per pattern				Length [mm]	PU	Order number
	1	2n	3n	4n			
5	-	1	-	-	62	5	9-33444-01-0-1
	-	1	-	-	800	5	9-33444-06-0-1
	-	1	-	-	1800	5	9-33444-18-0-1
	-	1	-	-	3050	5	9-33444-33-0-1
	-	1	-	-	6000	5	9-33444-60-0-1

Installation drawing 0-43952

You will find further versions and finishes in Chapter Individual parts from page 390.

Fanlight opening system VENTUS F200

Hand lever / pitched window

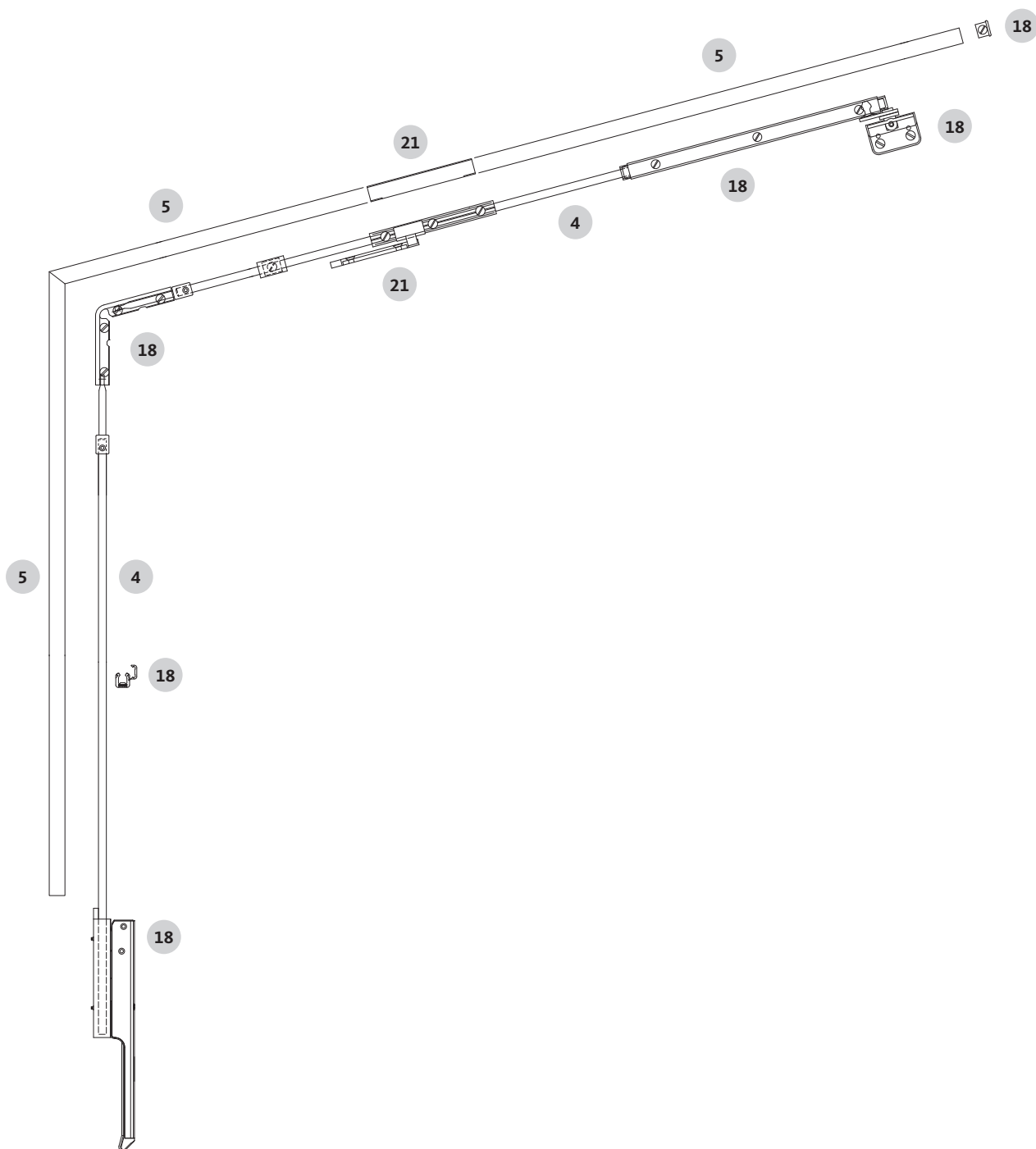

Fanlight opening system VENTUS F200

Hand lever / pitched window



Basic hardware set VENTUS F200 for pitched windows

Item	Piece per pattern				Overlap height [mm]	PU	Order number
	1	2n	3n	4n			
18	1	-	-	-	0-25	1	K-15206-00-0-1
	Alternative: basic hardware set VENTUS F200 for pitched windows Application vertical gear or lateral ELTRAL						
	1	-	-	-	0-25	1	K-15207-00-0-1
	Alternative: basic hardware set VENTUS F200 for pitched windows Application corner drive-gear or top ELTRAL						
	1	-	-	-	0-25	1	K-15208-00-0-1

Connecting rod and horizontal rod – Ø 8 mm

Item	Piece per pattern				Length [mm]	PU	Order number
	1	2n	3n	4n			
4	1	-	-	-	1850	1	9-25476-18-0-1
					3300		9-25476-33-0-1
					6000		9-25476-60-0-1

Cover profile

Item	Piece per pattern				Length [mm]	PU	Order number
	1	2n	3n	4n			
5	1	-	-	-	1800	5	9-33444-18-0-1
					3050		9-33444-33-0-1
					6000		9-33444-60-0-1

Additional lock VENTUS F200 horizontal

Item	Piece per pattern				SWp (pitched) [mm]	Overlap height [mm]	PU	Order number
	1	2n	3n	4n				
21	1	-	-	-	1200-1600			
	2	-	-	-	1601-2000			
	For timber / PVC windows with overlap					from 16	1	K-12008-00-0-1
	For metal windows with overlap					6-7	1	K-13033-60-0-1
						7-8	1	K-13033-70-0-1
						8-9	1	K-13033-80-0-1
						9-10	1	K-13033-90-0-1
	For flush metal / timber windows					-	1	K-13033-01-0-1

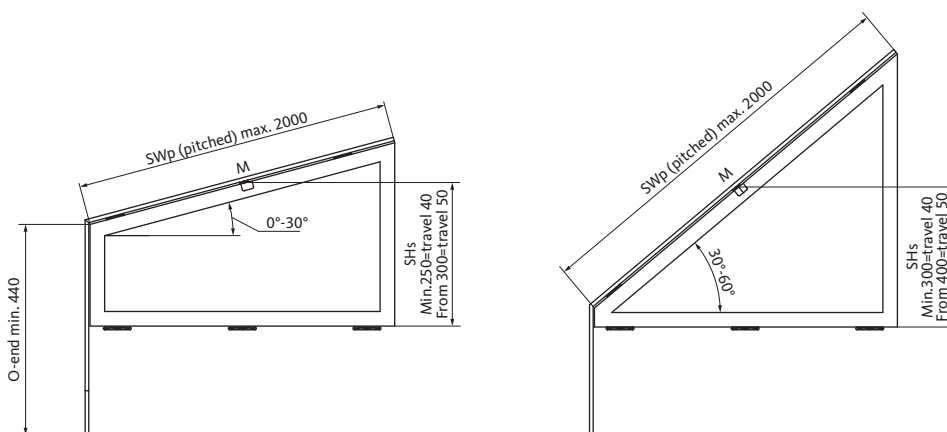

Installation drawing 0-43798

You will find further versions and finishes in Chapter Individual parts from page 390.

Fanlight opening system VENTUS F200

Hand lever – individual and total rod length

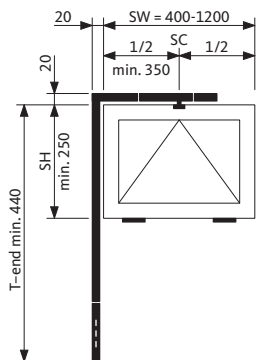

Pattern 1

Rod length according to total door leaf width and dimension O-end

O-end	Connector rod length	Total sash width dim. SW			
		700	800	1000	1200
		Horizontal rod length			
		365	415	515	615
1000	767	1132	1182	1282	1382
1100	867	1232	1282	1382	1482
1200	967	1332	1382	1482	1582
1300	1067	1432	1482	1582	1682
1400	1167	1532	1582	1682	1782
1500	1267	1632	1682	1782	1882
1600	1367	1732	1782	1882	1982
1700	1467	1832	1882	1982	2082
1800	1567	1932	1982	2082	2182
1900	1667	2032	2082	2182	2282
2000	1767	2132	2182	2282	2382

Rod and cover profile size 18 = white, 33 = grey

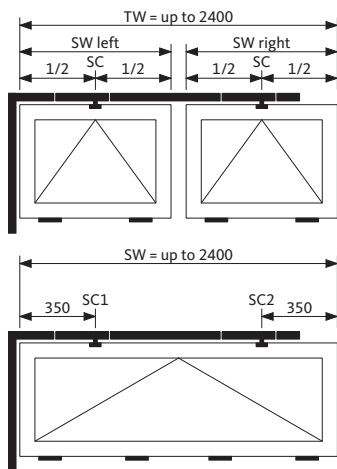

Pattern 2n

Rod length according to total door leaf width and dimension O-end

O-end	Connector rod length	Total sash width dim. SW or B					
		1400	1600	1800	2000	2200	2400
		Horizontal rod length					
		1065	1265	1465	1665	1865	2065
1000	767	1832	2032	2232	2432	2632	2832
1100	867	1932	2132	2332	2532	2732	2932
1200	967	2032	2232	2432	2632	2832	3032
1300	1067	2132	2332	2532	2732	2932	3132
1400	1167	2232	2432	2632	2832	3032	3232
1500	1267	2332	2532	2732	2932	3132	3332
1600	1367	2432	2632	2832	3032	3232	3432
1700	1467	2532	2732	2932	3132	3332	3532
1800	1567	2632	2832	3032	3232	3432	3632
1900	1667	2732	2932	3132	3332	3532	3732
2000	1767	2832	3032	3232	3432	3632	3832

Rod and cover profile size 33 = grey, 60 = white

Fanlight opening system VENTUS F200

Hand lever – individual and total rod length

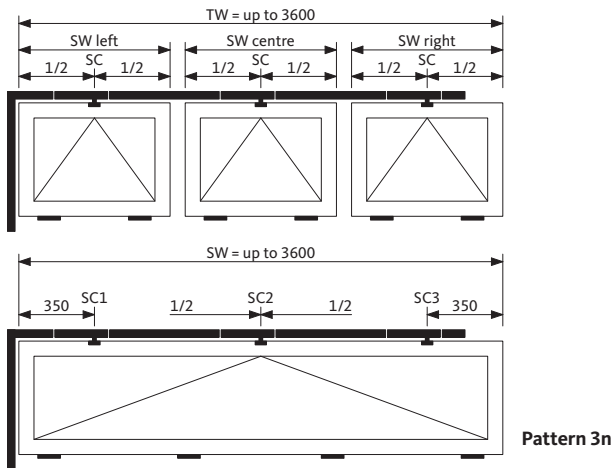

Pattern 3n

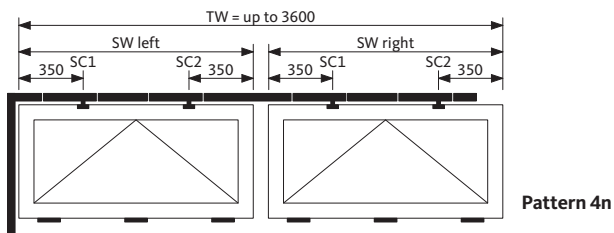

Pattern 4n

Rod length according to total door leaf width and dimension O-end

O-end	Connector rod length	Total sash width dim. SW or B					
		2600	2800	3000	3200	3400	3600
		Horizontal rod length					
		2265	2465	2665	2865	3065	3265
1000	767	3032	3232	3432	3632	3832	4032
1100	867	3132	3332	3532	3732	3932	4132
1200	967	3232	3432	3632	3832	4032	4232
1300	1067	3332	3532	3732	3932	4132	4332
1400	1167	3432	3632	3832	4032	4232	4432
1500	1267	3532	3732	3932	4132	4332	4532
1600	1367	3632	3832	4032	4232	4432	4632
1700	1467	3732	3932	4132	4332	4532	4732
1800	1567	3832	4032	4232	4432	4632	4832
1900	1667	3932	4132	4332	4532	4732	4932
2000	1767	4032	4232	4432	4632	4832	5032

Rod and cover profile size 33 = grey, 60 = white

Rod length according to total door leaf width and dimension O-end

O-end	Connector rod length	Total sash width dim. SW or B					
		2600	2800	3000	3200	3400	3600
		Horizontal rod length					
		2265	2465	2665	2865	3065	3265
1000	767	3032	3232	3432	3632	3832	4032
1100	867	3132	3332	3532	3732	3932	4132
1200	967	3232	3432	3632	3832	4032	4232
1300	1067	3332	3532	3732	3932	4132	4332
1400	1167	3432	3632	3832	4032	4232	4432
1500	1267	3532	3732	3932	4132	4332	4532
1600	1367	3632	3832	4032	4232	4432	4632
1700	1467	3732	3932	4132	4332	4532	4732
1800	1567	3832	4032	4232	4432	4632	4832
1900	1667	3932	4132	4332	4532	4732	4932
2000	1767	4032	4232	4432	4632	4832	5032

Rod and cover profile size 33 = grey, 60 = white

Fanlight opening system VENTUS F200

Crank / vertical gear

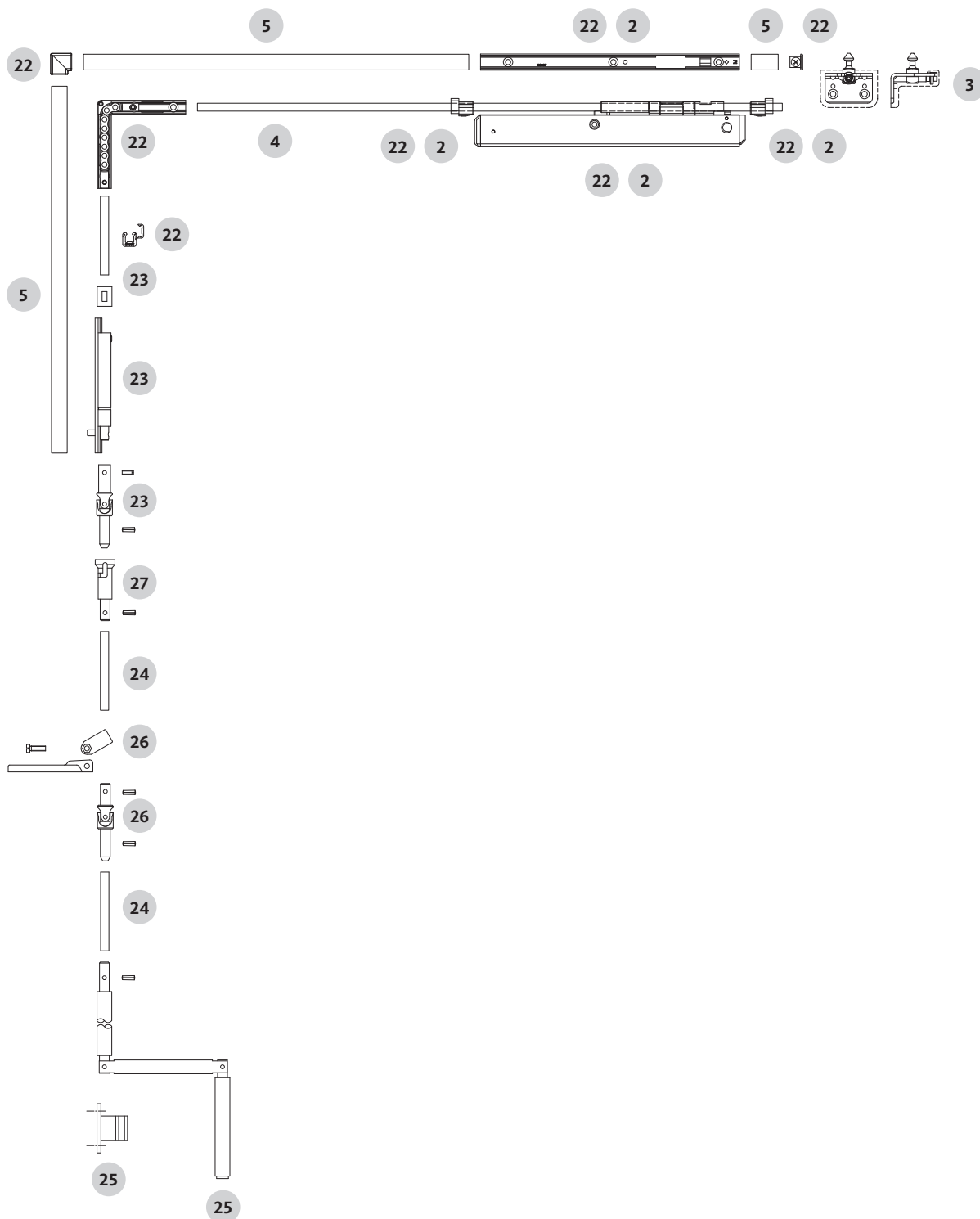

Fanlight opening system VENTUS F200

Crank / vertical gear



Basic hardware set VENTUS F200

Item	Piece per pattern				Opening width [mm]	PU	Order number
	1	2n	3n	4n			
22	1	1	1	1	200	2	K-15012-00-0-1

Opening stay VENTUS F200

Item	Piece per pattern				Opening width [mm]	PU	Order number
	1	2n	3n	4n			
2	-	1	2	3	200	1	K-15013-00-0-1

Sash bracket VENTUS F200 [1]

Item	Piece per pattern				Overlap height [mm]	PU	Order number
	1	2n	3n	4n			
3	1	2	3	4	0-25	2	K-15225-00-0-1

Vertical gear

Item	Piece per pattern				PU	Order number
	1	2n	3n	4n		
23	1	1	1	1	1	K-13402-00-0-1

Articulated crank rod and accessories according to version a to h

Crank rod

Item	Specifications								Length [mm]	PU	Order number
	a	b	c	d	e	f	g	h			
24	1	1	1	1	1	1	1	1	5000	1	9-32230-50-0-1

Articulated crank

Item	Version								PU	Order number	
	a	b	c	d	e	f	g	h			
25	1	1	1	1	1	1	1	1	1	1	K-13162-00-0-1

Connecting rod and horizontal rod – Ø 8 mm

Item	Piece per pattern				Length [mm]	PU	Order number
	1	2n	3n	4n			
4	1	1	1	1	600	1	9-25476-06-0-1
					1850		9-25476-18-0-1
					3300		9-25476-33-0-1
					6000		9-25476-60-0-1

Cover profile

Item	Piece per pattern				Length [mm]	PU	Order number
	1	2n	3n	4n			
5	1	1	1	1	62	5	9-33444-01-0-1
					800		9-33444-06-0-1
					1800		9-33444-18-0-1
					3050		9-33444-33-0-1
					6000		9-33444-60-0-1

Crank rod universal joint

Item	Version								PU	Order number	
	a	b	c	d	e	f	g	h			
26	-	-	1	1	2	2	1	1	1	1	K-13164-00-0-1

Coupling bush

Item	Version								PU	Order number	
	a	b	c	d	e	f	g	h			
27	-	1	-	1	-	1	-	1	1	1	K-13165-00-0-1

[1] Use insert according to the constitution of the profile.
 – Timber: 9-34508-00-0-0
 – PVC: 9-33105-00-0-1

Installation drawing 0-44556 / 0-43700

You will find further versions and finishes in Chapter Individual parts from page 390.

Fanlight opening system VENTUS F200

Crank / vertical gear

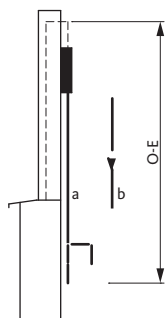

O-B min.	T
310	30
345	60
380	90
415	120
450	150
485	180
525	210
560	240
595	270
630	300

O-E min.	Vers.
715	a
765	b

Version a and b

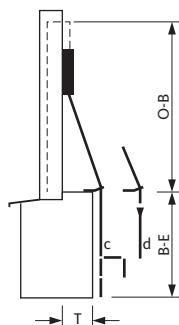

O-B min.	T
310	30
345	60
380	90
415	120
450	150
485	180
525	210
560	240
595	270
630	300

B-E min.	Vers.
475	c
515	d

Version c and d

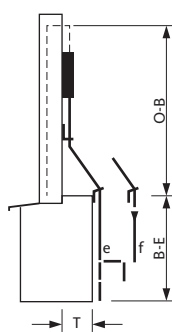

O-B min.	T
515	30
565	60
615	90
670	120
720	150
775	180
825	210
875	240
930	270
985	300

B-E min.	Vers.
475	e
515	f

Version e and f

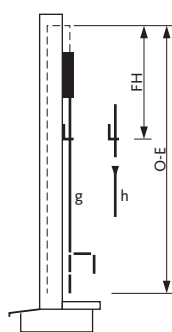

SH min.
400

O-E min.	Vers.
800	g
850	h

Version g and h

Fanlight opening system VENTUS F200

Crank / vertical gear

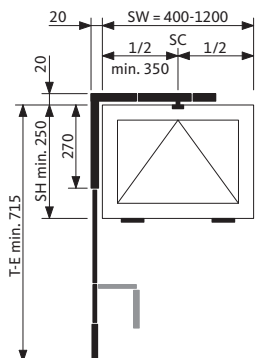

Pattern 1

Horizontal rod length depending on total sash width

	Total sash width dim. SW			
	700	800	1000	1200
Horizontal rod length	365	415	515	615

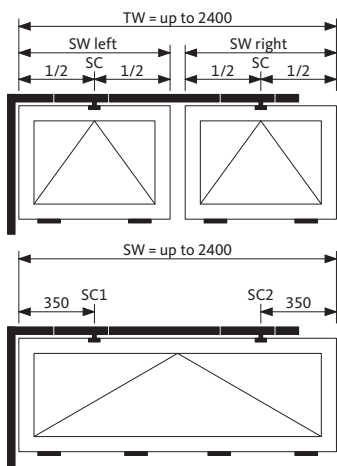

Pattern 2n

Horizontal rod length depending on total sash width

	Total sash width dim. SW or B					
	1400	1600	1800	2000	2200	2400
Horizontal rod length	1065	1265	1465	1665	1865	2065

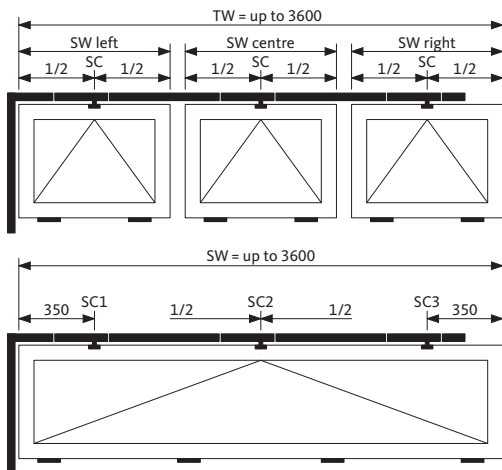

Pattern 3n

Horizontal rod length depending on total sash width

	Total sash width dim. SW or B					
	2600	2800	3000	3200	3400	3600
Horizontal rod length	2265	2465	2665	2865	3065	3265

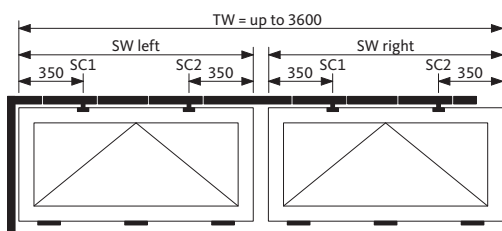

Pattern 4n

Horizontal rod length depending on total sash width

	Total sash width dim. SW or B					
	2600	2800	3000	3200	3400	3600
Horizontal rod length	2265	2465	2665	2865	3065	3265

Fanlight opening system VENTUS F200

Crank / corner drive-gear

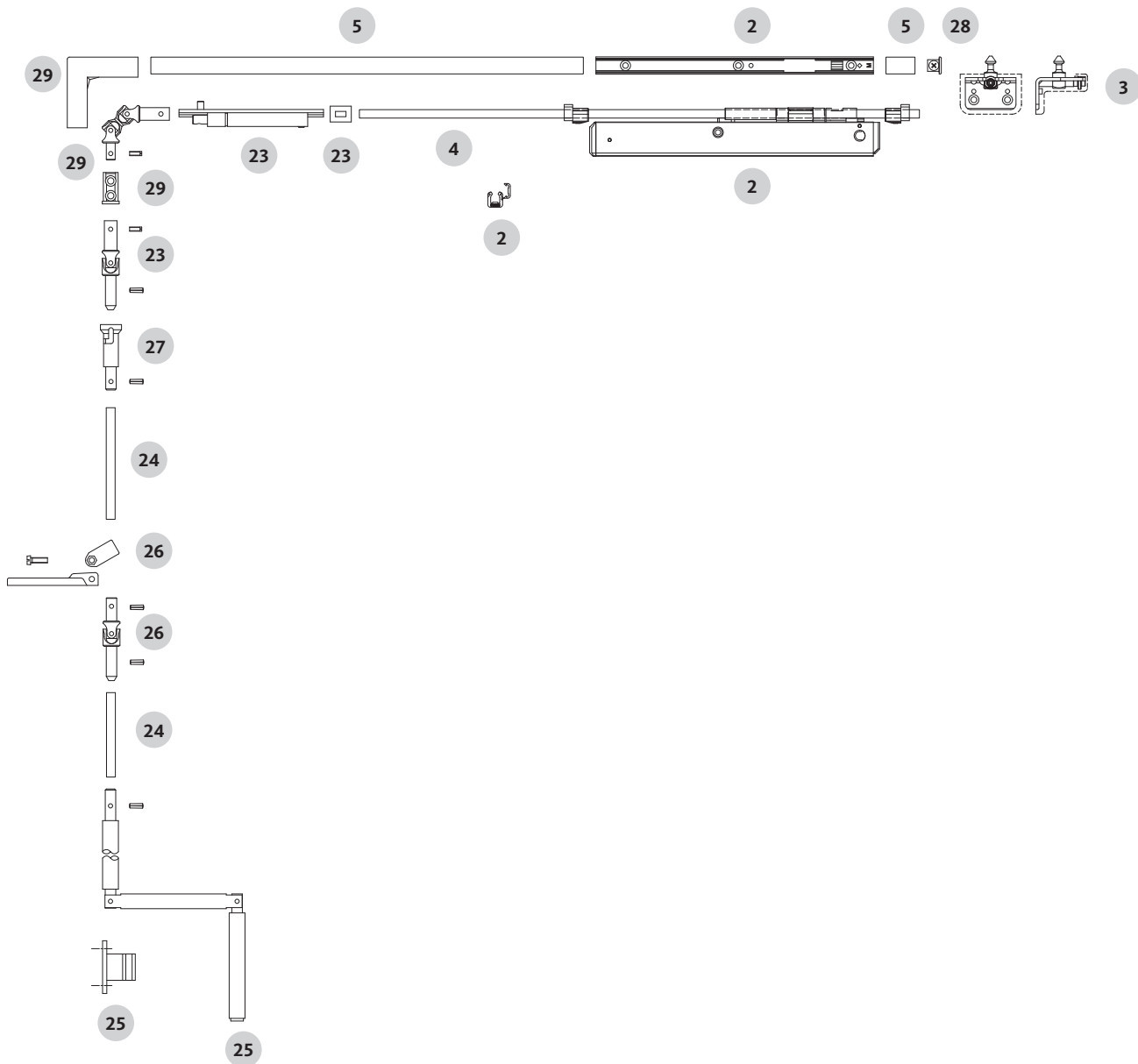

Fanlight opening system VENTUS F200

Crank / corner drive-gear



Opening stay VENTUS F200

Item	Piece per pattern				Opening width [mm]	PU	Order number
	1	2n	3n	4n			
2	1	2	3	4	200	1	K-15013-00-0-1

End cap

Item	Piece per pattern				PU	Order number
	1	2n	3n	4n		
28	1	1	1	1	1	9-34412-00-0-6

Sash bracket VENTUS F200 [1]

Item	Piece per pattern				Overlap height [mm]	PU	Order number
	1	2n	3n	4n			
3	1	2	3	4	0-25	2	K-15225-00-0-1

Vertical gear

Item	Piece per pattern				PU	Order number
	1	2n	3n	4n		
23	1	1	1	1	1	K-13402-00-0-1

Additional parts for corner drive-gear

Item	Piece per pattern				PU	Order number
	1	2n	3n	4n		
29	1	1	1	1	1	K-13403-00-0-1

Articulated crank rod and accessories according to version a to d

Crank rod

Item	Version				Length [mm]	PU	Order number
	a	b	c	d			
24	1	1	1	1	5000	1	9-32230-50-0-1

Articulated crank

Item	Version				PU	Order number
	a	b	c	d		
25	1	1	1	1	1	K-13162-00-0-1

Connecting rod and horizontal rod – Ø 8 mm

Item	Piece per pattern				Length [mm]	PU	Order number
	1	2n	3n	4n			
4	1	1	1	1	600	1	9-25476-06-0-1
					1850		9-25476-18-0-1
					3300		9-25476-33-0-1
					6000		9-25476-60-0-1

Cover profile

Item	Piece per pattern				Length [mm]	PU	Order number
	1	2n	3n	4n			
5	1	1	1	1	62	5	9-33444-01-0-1
					800		9-33444-06-0-1
					1800		9-33444-18-0-1
					3050		9-33444-33-0-1
					6000		9-33444-60-0-1

Crank rod universal joint

Item	Version				PU	Order number
	a	b	c	d		
26	-	-	1	1	1	K-13164-00-0-1

Coupling bush

Item	Version				PU	Order number
	a	b	c	d		
27	-	1	-	1	1	K-13165-00-0-1

[1] Use insert according to the constitution of the profile.
 – Timber: 9-34508-00-0-0
 – PVC: 9-33105-00-0-1

Installation drawing 0-44556 / 0-43700

You will find further versions and finishes in Chapter Individual parts from page 390.

Fanlight opening system VENTUS F200

Crank / corner drive-gear

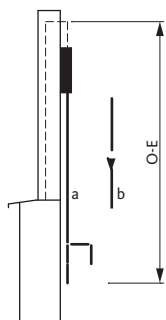

Version a and b

O-B min.	T
200	30
200	60
200	90
210	120
245	150
280	180
315	210
350	240
390	270
425	300
O-E min.	Vers.
505	a
555	b

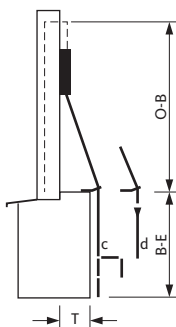

Version c and d

O-B min.	T
200	30
200	60
200	90
210	120
245	150
280	180
315	210
350	240
390	270
425	300
B-E min.	Vers.
475	c
515	d

Fanlight opening system VENTUS F200

Crank / corner drive-gear

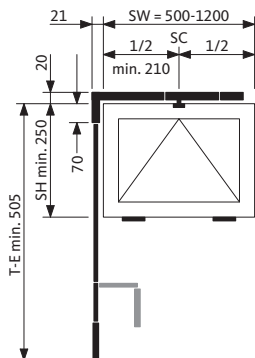

Pattern 1

Horizontal rod length depending on total sash width

	Total sash width dim. SW			
	700	800	1000	1200
Horizontal rod length	486	536	636	736

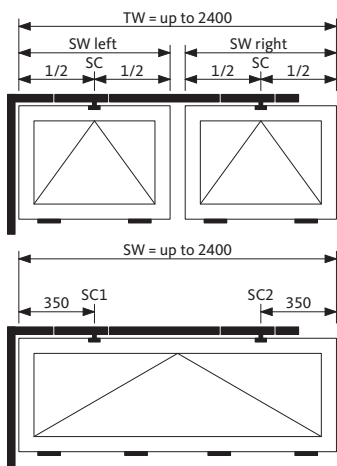

Pattern 2n

Horizontal rod length depending on total sash width

	Total sash width dim. SW or B					
	1400	1600	1800	2000	2200	2400
Horizontal rod length	1186	1386	1586	1786	1986	2186

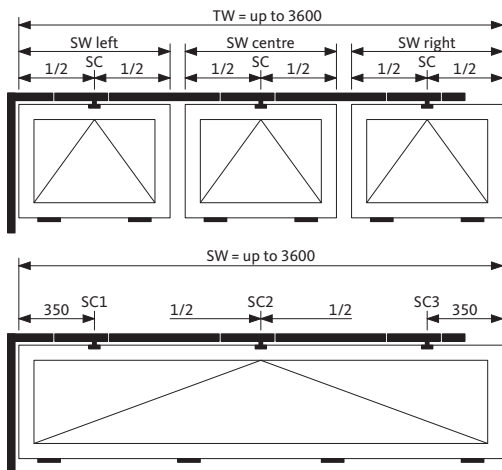

Pattern 3n

Horizontal rod length depending on total sash width

	Total sash width dim. SW or B					
	2600	2800	3000	3200	3400	3600
Horizontal rod length	2386	2586	2786	2986	3186	3386

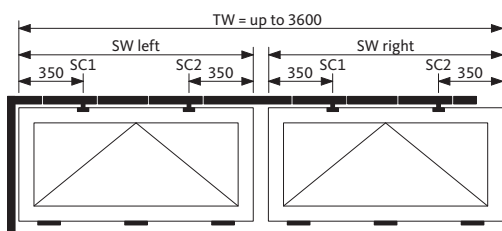

Pattern 4n

Horizontal rod length depending on total sash width

	Total sash width dim. SW or B					
	2600	2800	3000	3200	3400	3600
Horizontal rod length	2386	2586	2786	2986	3186	3386

Fanlight opening system VENTUS F200

Hand lever / Top-Hung window outward opening

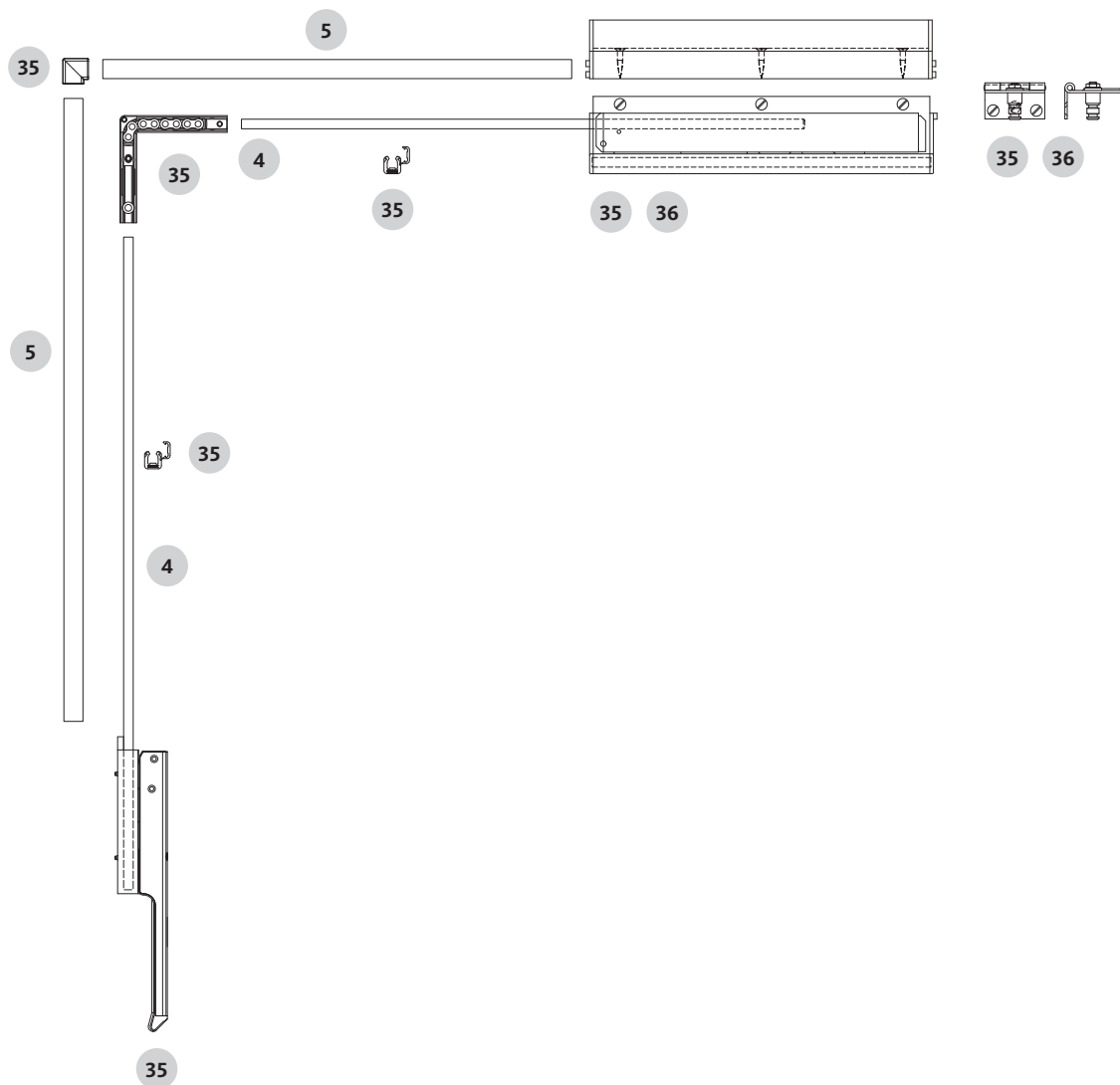

Dim. Y
Timber

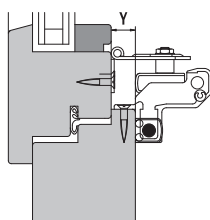

PVC

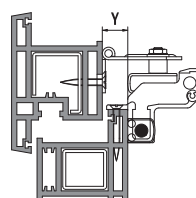

Metal

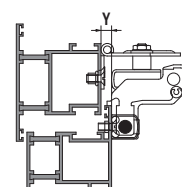

Fanlight opening system VENTUS F200

Hand lever / Top-Hung window outward opening



Basic hardware set VENTUS F200 [1]

Item	Piece per pattern				Opening width [mm]	Dim. Y [mm]	PU	Order number
	1	2n	3n	4n				
35	1	1	1	-	200	0-4	1	K-15168-00-L-1
						5-13		K-15165-00-L-1
						14-25		K-15164-25-L-1
						26-50		K-15164-50-L-1
						51-75		K-15164-75-L-1

Opening stay VENTUS F200 [1]

Item	Piece per pattern				Opening width [mm]	Dim. Y [mm]	PU	Order number
	1	2n	3n	4n				
36	-	1	2	-	200	0-4	1	K-15169-00-L-1
						5-13		K-15167-00-L-1
						14-25		K-15166-25-L-1
						26-50		K-15166-50-L-1
						51-75		K-15166-75-L-1

Connecting rod and horizontal rod – Ø 8 mm

Item	Piece per pattern				Length [mm]	PU	Order number
	1	2n	3n	4n			
4	1	1	1	-	1850	1	9-25476-18-0-1
					3300		9-25476-33-0-1
					6000		9-25476-60-0-1

Cover profile

Item	Piece per pattern				Length [mm]	PU	Order number
	1	2n	3n	4n			
5	1	1	1	-	1800	5	9-33444-18-0-1
					3050		9-33444-33-0-1
					6000		9-33444-60-0-1

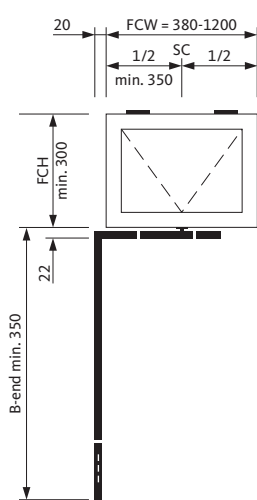

Pattern 1 – Hand lever

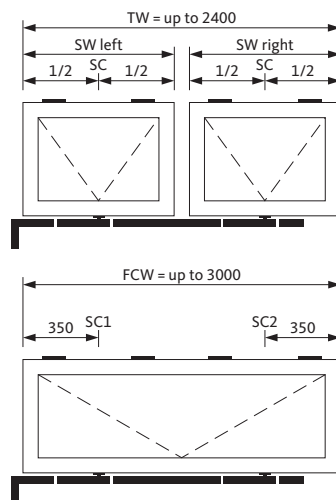

Pattern 2n

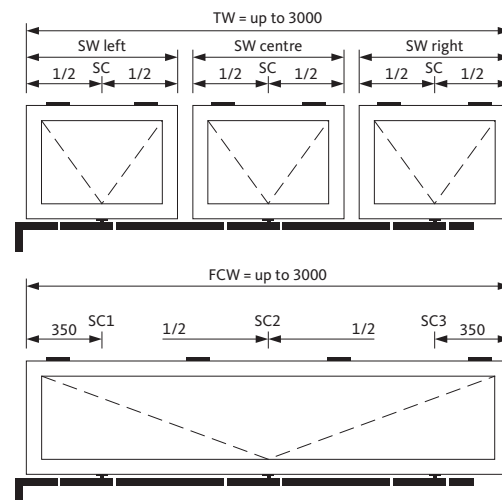

Pattern 3n

[1] Can be retrofitted from left operation to right operation

Installation drawing 0-43818

You will find further versions and finishes in Chapter Individual parts from page 390.

Fanlight opening system VENTUS F200

Crank / Vertical gear / Top-Hung window outward opening

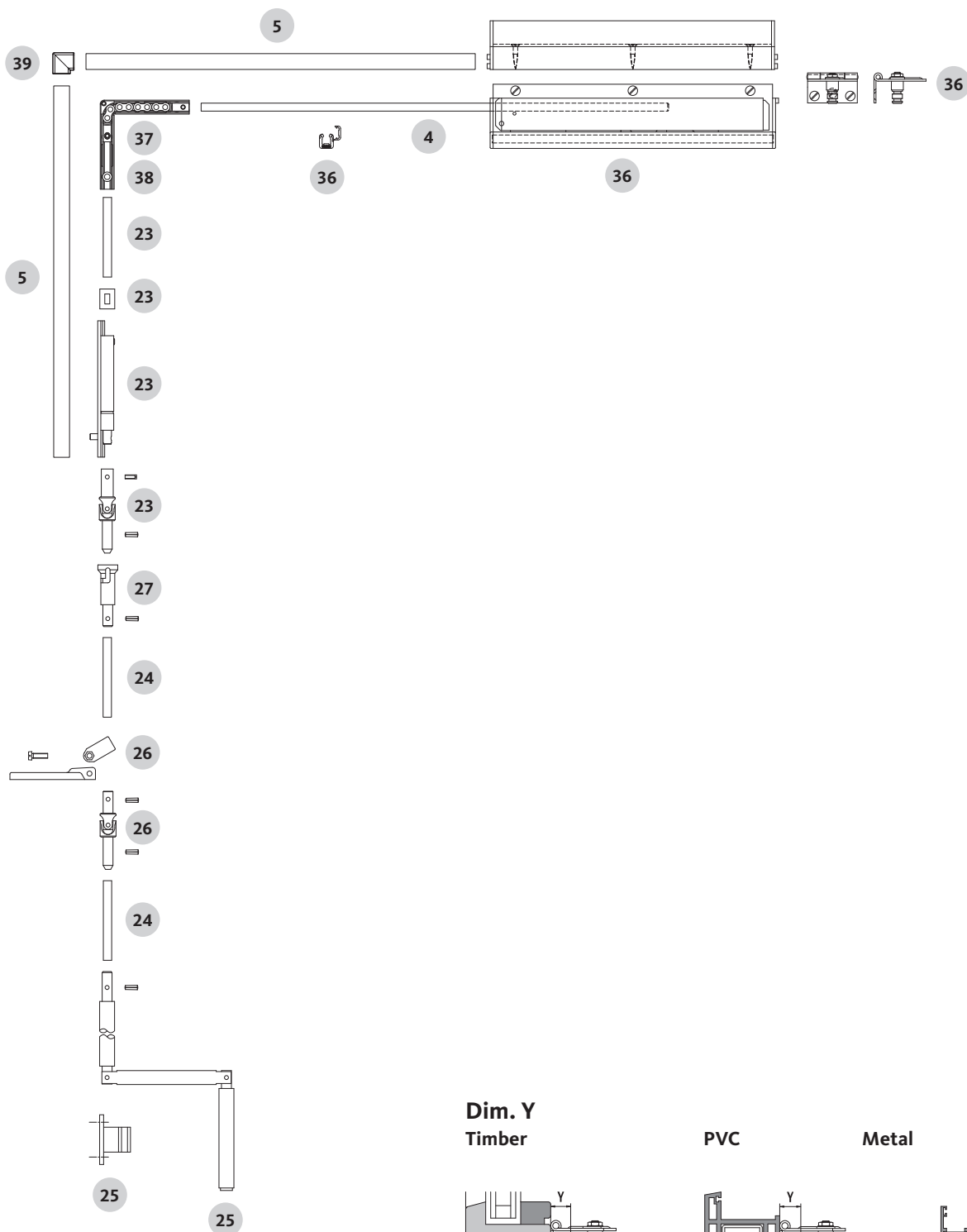

Dim. Y
Timber

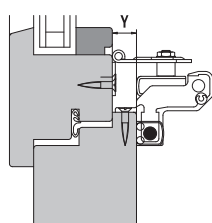

PVC

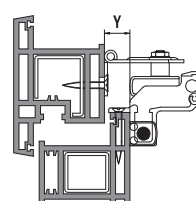

Metal

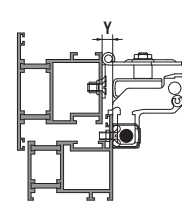

Fanlight opening system VENTUS F200

Crank / Vertical gear / Top-Hung window outward opening



Opening stay VENTUS F200 [1]

Item	Piece per pattern				Opening width [mm]	Dim. Y [mm]	PU	Order number
	1	2n	3n	4n				
36	1	2	3	-	200	0-4	1	K-15169-00-L-1
						5-13		K-15167-00-L-1
						14-25		K-15166-25-L-1
						26-50		K-15166-50-L-1
						51-75		K-15166-75-L-1

Chain with rod clamps

Item	Piece per pattern				PU	Order number
	1	2n	3n	4n		
37	1	1	1	-	1	6-29313-00-0-1

Corner guide

Item	Piece per pattern				PU	Order number
	1	2n	3n	4n		
38	1	1	1	-	1	9-38261-00-0-0

Corner cover

Item	Piece per pattern				PU	Order number
	1	2n	3n	4n		
39	1	1	1	-	1	9-34220-00-0-6

Vertical gear

Item	Piece per pattern				PU	Order number
	1	2n	3n	4n		
23	1	1	1	-	1	K-13402-00-0-1

Articulated crank rod and accessories according to version a to h

Crank rod

Item	Specifications								Length [mm]	PU	Order number
	a	b	c	d	e	f	g	h			
24	1	1	1	1	1	1	1	1	5000	1	9-32230-50-0-1

Articulated crank

Item	Specifications								PU	Order number	
	a	b	c	d	e	f	g	h			
25	1	1	1	1	1	1	1	1	1	1	K-13162-00-0-1

Connecting rod and horizontal rod – Ø 8 mm

Item	Piece per pattern				Length [mm]	PU	Order number
	1	2n	3n	4n			
4	1	1	1	-	600	1	9-25476-06-0-1
					1850		9-25476-18-0-1
					3300		9-25476-33-0-1
					6000		9-25476-60-0-1

Cover profile

Item	Piece per pattern				Length [mm]	PU	Order number
	1	2n	3n	4n			
5	1	1	1	-	800	5	9-33444-06-0-1
					1800		9-33444-18-0-1
					3050		9-33444-33-0-1
					6000		9-33444-60-0-1

Crank rod universal joint

Item	Specifications								PU	Order number	
	a	b	c	d	e	f	g	h			
26	-	-	1	1	2	2	1	1	1	1	K-13164-00-0-1

Coupling bush

Item	Specifications								PU	Order number	
	a	b	c	d	e	f	g	h			
27	-	1	-	1	-	1	-	1	1	1	K-13165-00-0-1

[1] Can be retrofitted from left operation to right operation

Installation drawing 0-43818 / 0-44556

You will find further versions and finishes in Chapter Individual parts from page 390.

Fanlight opening system VENTUS F200

Crank / Corner drive-gear / Top-Hung window outward opening

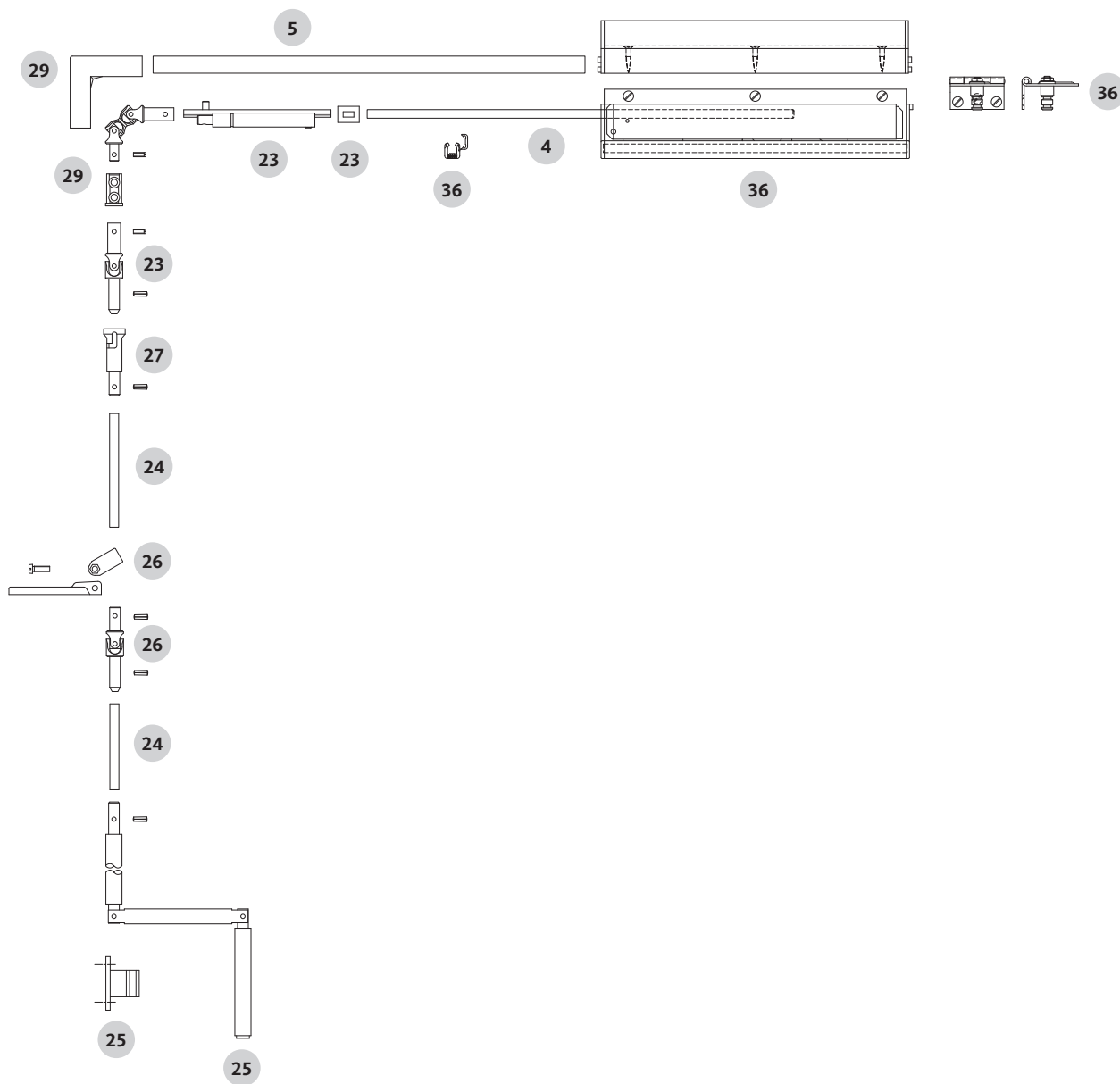

Dim. Y
Timber

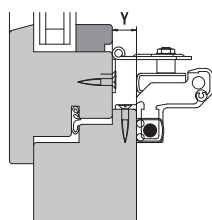

PVC

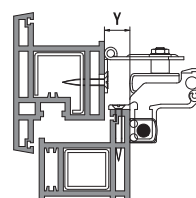

Metal

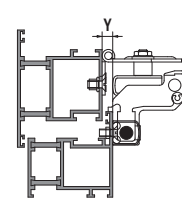

Fanlight opening system VENTUS F200

Crank / Corner drive-gear / Top-Hung window outward opening



Opening stay VENTUS F200 [1]

Item	Piece per pattern				Dim. Y [mm]	PU	Order number
	1	2n	3n	4n			
36	1	2	3	-	0-4	1	K-15169-00-L-1
					5-13		K-15167-00-L-1
					14-25		K-15166-25-L-1
					26-50		K-15166-50-L-1
					51-75		K-15166-75-L-1

Vertical gear

Item	Piece per pattern				PU	Order number
	1	2n	3n	4n		
23	1	1	1	-	1	K-13402-00-0-1

Additional parts for corner drive-gear

Item	Piece per pattern				PU	Order number
	1	2n	3n	4n		
29	1	1	1	-	1	K-13403-00-0-1

Connecting rod and horizontal rod – Ø 8 mm

Item	Piece per pattern				Length [mm]	PU	Order number
	1	2n	3n	4n			
4	1	1	1	-	600	1	9-25476-06-0-1
					1850		9-25476-18-0-1
					3300		9-25476-33-0-1
					6000		9-25476-60-0-1

Cover profile

Item	Piece per pattern				Length [mm]	PU	Order number
	1	2n	3n	4n			
5	1	1	1	-	800	5	9-33444-06-0-1
					1800		9-33444-18-0-1
					3050		9-33444-33-0-1
					6000		9-33444-60-0-1

Articulated crank rod and accessories according to version a to d

Crank rod

Item	Version				Length [mm]	PU	Order number
	a	b	c	d			
24	1	1	1	1	5000	1	9-32230-50-0-1

Crank rod universal joint

Item	Version				PU	Order number
	a	b	c	d		
26	-	-	1	1	1	K-13164-00-0-1

Articulated crank

Item	Version				PU	Order number
	a	b	c	d		
25	1	1	1	1	1	K-13162-00-0-1

Coupling bush

Item	Version				PU	Order number
	a	b	c	d		
27	-	1	-	1	1	K-13165-00-0-1

[1] Can be retrofitted from left operation to right operation

Installation drawing 0-43818 / 0-44556

You will find further versions and finishes in Chapter Individual parts from page 390.

Fanlight opening system VENTUS F200

Individual parts – basic hardware set VENTUS F200

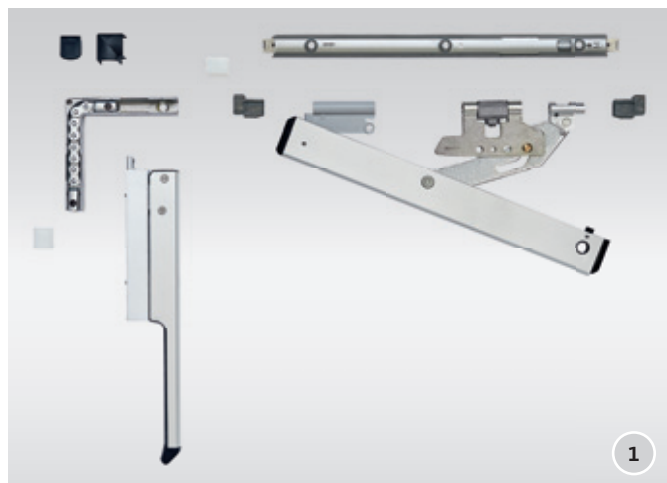

Integral parts

- Stay
- Stay-bearing
- Rod bearing
- Corner guide
- Chain with rod clamps
- Hand lever
- Guide
- Corner cover
- End cap

Basic hardware set VENTUS F200

Technical data	
Specifications	with hand lever
Opening type	Bottom-Hung window
Opening direction	inward
Opening width	200 mm
DIN stop	left right

Finish	PU	Order number
Silver	2 pc	K-15011-00-0-1
Brown	2 pc	K-15011-00-0-5
White	2 pc	K-15011-00-0-7

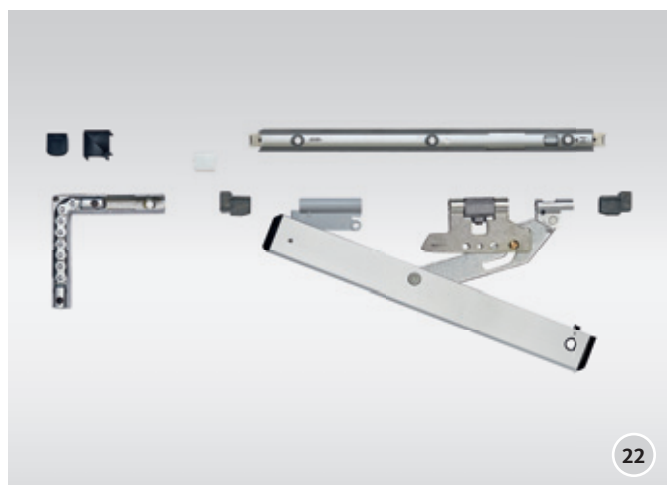

Integral parts

- Stay
- Stay-bearing
- Rod bearing
- Corner guide
- Chain with rod clamps
- Guide
- Corner cover
- End cap

Basic hardware set VENTUS F200

Technical data	
Opening type	Bottom-Hung window
Opening direction	inward
Opening width	200 mm
DIN stop	left right

Finish	PU	Order number
Silver	2 pc	K-15012-00-0-1
Brown	2 pc	K-15012-00-0-5
White	2 pc	K-15012-00-0-7

Fanlight opening system VENTUS F200

Individual parts – basic hardware set VENTUS F200

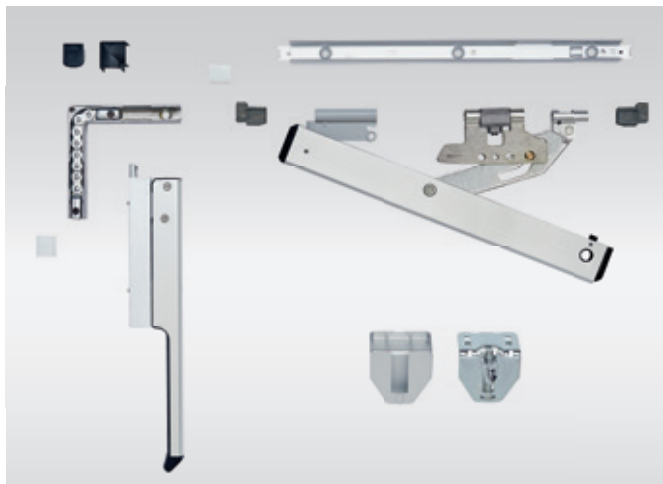

Integral parts

- Stay
- Stay-bearing
- Rod bearing
- Corner guide
- Chain with rod clamps
- Hand lever
- High sash bracket
- Cover cap
- Guide
- Corner cover
- End cap

Basic hardware set VENTUS F200

Technical data	
Specifications	with hand lever with sash bracket
Opening type	Bottom-Hung window
Opening direction	inward
Opening width	200 mm
DIN stop	left right
Overlap height	0–25 mm

Finish	PU	Order number
Silver	250 pc	K-15247-00-0-1
Brown	1 pc	K-15247-00-0-5
White	1 pc	K-15247-00-0-7

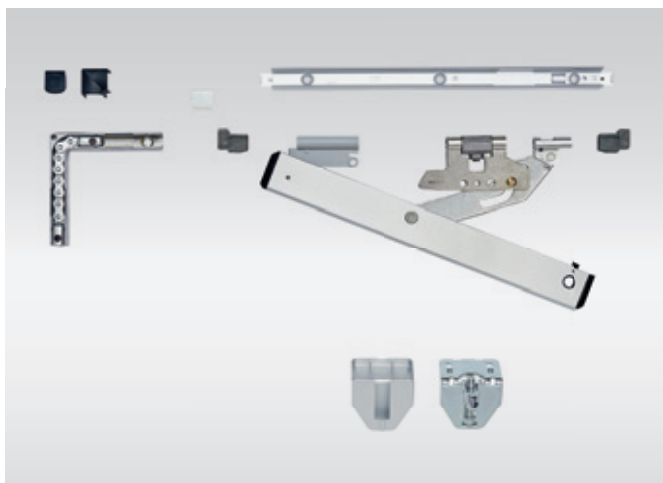

Integral parts

- Stay
- Stay-bearing
- Rod bearing
- Corner guide
- Chain with rod clamps
- High sash bracket
- Cover cap
- Guide
- Corner cover
- End cap

Basic hardware set VENTUS F200

Technical data	
Specifications	with sash bracket
Opening type	Bottom-Hung window
Opening direction	inward
Opening width	200 mm
DIN stop	left right
Overlap height	0–25 mm

Finish	PU	Order number
Silver	1 pc	K-15255-00-0-1
Brown	1 pc	K-15255-00-0-5
White	50 pc	K-15255-00-0-7

Fanlight opening system VENTUS F200

Individual parts – basic hardware set VENTUS F200

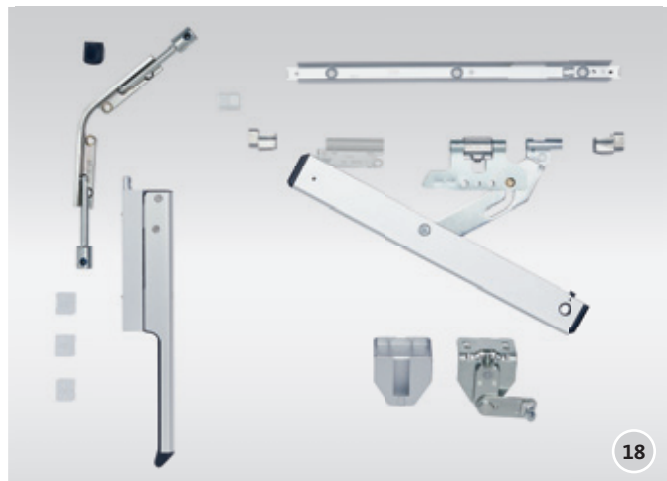

18

Integral parts

- Stay
- Stay-bearing
- Rod bearing
- Pitched corner angle
- Hand lever
- Sash bracket with joint
- Cover cap
- Guide
- End cap

Basic hardware set VENTUS F200 for pitched windows

Technical data	
Specifications	with hand lever with sash bracket
Window form	Pitched window
Opening type	Bottom-Hung window
Opening direction	inward
Opening width	200 mm
DIN stop	left right
Overlap height	0–25 mm

Finish	PU	Order number
Silver	1 pc	K-15206-00-0-1
Brown	1 pc	K-15206-00-0-5
White	1 pc	K-15206-00-0-7

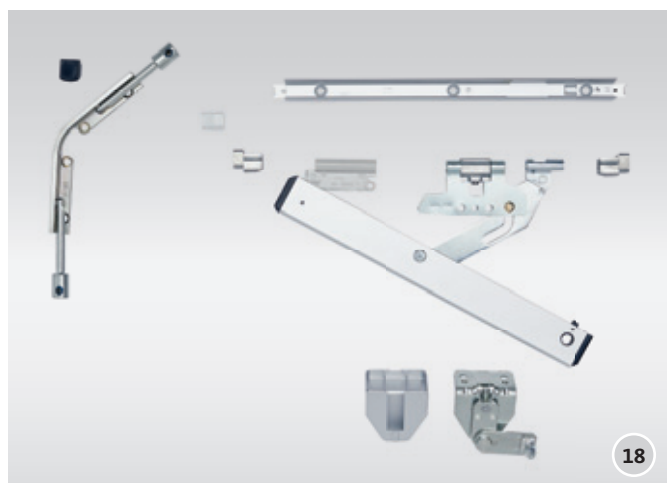

18

Integral parts

- Stay
- Stay-bearing
- Rod bearing
- Pitched corner angle
- Sash bracket with joint
- Cover cap
- Guide
- End cap

Basic hardware set VENTUS F200 for pitched windows

Technical data	
Use	with vertical gear or lateral ELTRAL
Specifications	with sash bracket
Window form	Pitched window
Opening type	Bottom-Hung window
Opening direction	inward
Opening width	200 mm
DIN stop	left right
Overlap height	0–25 mm

Finish	PU	Order number
Silver	1 pc	K-15207-00-0-1
Brown	1 pc	K-15207-00-0-5
White	1 pc	K-15207-00-0-7

Fanlight opening system VENTUS F200

Individual parts – basic hardware set VENTUS F200



18

Integral parts

- Stay
- Stay-bearing
- Rod bearing
- Sash bracket with joint
- Cover cap
- Guide
- End cap

Basic hardware set VENTUS F200 for pitched windows

Technical data	
Use	with corner drive-gear or top ELTRAL
Specifications	with sash bracket
Window form	Pitched window
Opening type	Bottom-Hung window
Opening direction	inward
Opening width	200 mm
DIN stop	left right
Overlap height	0–25 mm

Finish	PU	Order number
Silver	1 pc	K-15208-00-0-1
Brown	1 pc	K-15208-00-0-5
White	1 pc	K-15208-00-0-7

Fanlight opening system VENTUS F200

Individual parts – basic hardware set VENTUS F200



Integral parts

- Stay 2
- Sash bracket
- Corner guide
- Chain with rod clamps
- Hand lever
- Guide
- Corner cover
- Tapped strip
- Cover cap
- Spacer plate
- Stay rod
- Sleeve

Basic hardware set VENTUS F200

Technical data	
Specifications	with hand lever with sash bracket
Opening type	Top-Hung window
Opening direction	outward
Opening width	200 mm
DIN stop	left [1]
Dim. Y	0–4 mm

Finish	PU	Order number
Silver	1 pc	K-15168-00-L-1
Brown	1 pc	K-15168-00-L-5
White	1 pc	K-15168-00-L-7



Integral parts

- Stay 2
- Sash bracket
- Corner guide
- Chain with rod clamps
- Hand lever
- Guide
- Corner cover
- Tapped strip
- Cover cap

Basic hardware set VENTUS F200

Technical data	
Specifications	with hand lever with sash bracket
Opening type	Top-Hung window
Opening direction	outward
Opening width	200 mm
DIN stop	left [1]
Dim. Y	5–13 mm

Finish	PU	Order number
Silver	1 pc	K-15165-00-L-1
Brown	1 pc	K-15165-00-L-5
White	1 pc	K-15165-00-L-7

[1] Can be retrofitted from left operation to right operation

Fanlight opening system VENTUS F200

Individual parts – basic hardware set VENTUS F200



35

Integral parts

- Stay 1
- Sash bracket
- Corner guide
- Chain with rod clamps
- Hand lever
- Guide
- Corner cover

Basic hardware set VENTUS F200

Technical data	
Specifications	with hand lever with sash bracket
Opening type	Top-Hung window
Opening direction	outward
Opening width	200 mm
DIN stop	left [1]
Dim. Y	14–25 mm

Finish	PU	Order number
Silver	1 pc	K-15164-25-L-1
Brown	1 pc	K-15164-25-L-5
White	1 pc	K-15164-25-L-7



35

Integral parts

- Stay 1
- Sash bracket
- Corner guide
- Chain with rod clamps
- Hand lever
- Guide
- Corner cover

Basic hardware set VENTUS F200

Technical data	
Specifications	with hand lever with sash bracket
Opening type	Top-Hung window
Opening direction	outward
Opening width	200 mm
DIN stop	left [1]
Dim. Y	26–50 mm

Finish	PU	Order number
Silver	1 pc	K-15164-50-L-1
Brown	1 pc	K-15164-50-L-5
White	1 pc	K-15164-50-L-7

[1] Can be retrofitted from left operation to right operation

Fanlight opening system VENTUS F200

Individual parts – basic hardware set VENTUS F200



Integral parts

- Stay 1
- Sash bracket
- Corner guide
- Chain with rod clamps
- Hand lever
- Guide
- Corner cover

Basic hardware set VENTUS F200

Technical data	
Specifications	with hand lever with sash bracket
Opening type	Top-Hung window
Opening direction	outward
Opening width	200 mm
DIN stop	left [1]
Dim. Y	51–75 mm

Finish	PU	Order number
Silver	1 pc	K-15164-75-L-1
Brown	1 pc	K-15164-75-L-5
White	1 pc	K-15164-75-L-7

[1] Can be retrofitted from left operation to right operation

Fanlight opening system VENTUS F200

Individual parts – opening stay VENTUS F200

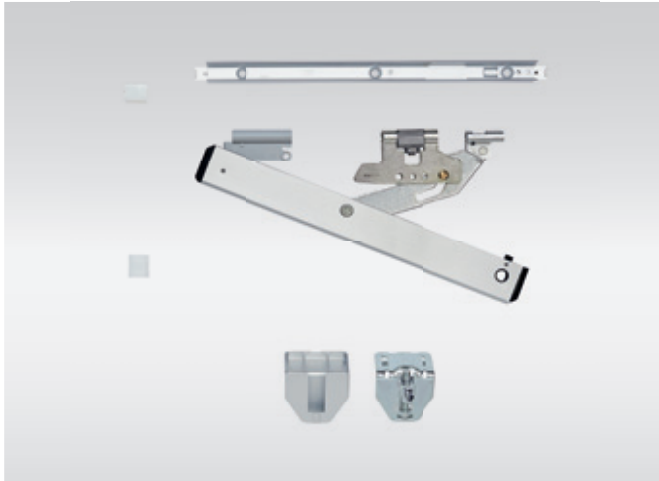

Integral parts

- Stay
- Stay-bearing
- Rod bearing
- High sash bracket
- Cover cap

Opening stay VENTUS F200

Technical data	
Specifications	with sash bracket
Opening type	Bottom-Hung window
Opening direction	inward
Opening width	200 mm
DIN stop	left right
Overlap height	0–25 mm

Finish	PU	Order number
Silver	1 pc	K-15248-00-0-1
Brown	1 pc	K-15248-00-0-5
White	1 pc	K-15248-00-0-7



Integral parts

- Stay
- Stay-bearing
- Rod bearing
- Guide

Opening stay VENTUS F200

Technical data	
Opening type	Bottom-Hung window
Opening direction	inward
Opening width	200 mm
DIN stop	left right

Finish	PU	Order number
Silver	1 pc	K-15013-00-0-1
Brown	1 pc	K-15013-00-0-5
White	1 pc	K-15013-00-0-7

Fanlight opening system VENTUS F200

Individual parts – opening stay VENTUS F200



15

Integral parts

- Short stay
- Short stay-bearing
- Rod bearing

Opening stay VENTUS F200 short

Technical data	
Window form	Pitched window round arch window
Opening type	Bottom-Hung window
Opening direction	inward
Opening width	150 mm
DIN stop	left right

Finish	PU	Order number
Silver	1 pc	K-15483-00-0-1
Brown	1 pc	K-15483-00-0-5
White	1 pc	K-15483-00-0-7



36

Integral parts

- Stay 2
- Sash bracket
- Guide
- Tapped strip
- Cover cap
- Spacer plate
- Stay rod 1
- Stay rod 2
- Sleeve

Opening stay VENTUS F200

Technical data	
Specifications	with sash bracket
Opening type	Top-Hung window
Opening direction	outward
Opening width	200 mm
DIN stop	left [1]
Dim. Y	0-4 mm

Finish	PU	Order number
Silver	1 pc	K-15169-00-L-1
Brown	1 pc	K-15169-00-L-5
White	1 pc	K-15169-00-L-7

[1] Can be retrofitted from left operation to right operation

Fanlight opening system VENTUS F200

Individual parts – opening stay VENTUS F200



Integral parts

- Stay 2
- Sash bracket
- Guide
- Tapped strip
- Cover cap

Opening stay VENTUS F200

Technical data	
Specifications	with sash bracket
Opening type	Top-Hung window
Opening direction	outward
Opening width	200 mm
DIN stop	left [1]
Dim. Y	5–13 mm

Finish	PU	Order number
Silver	1 pc	K-15167-00-L-1
Brown	1 pc	K-15167-00-L-5
White	1 pc	K-15167-00-L-7



Integral parts

- Stay 1
- Sash bracket
- Guide

Opening stay VENTUS F200

Technical data	
Specifications	with sash bracket
Opening type	Top-Hung window
Opening direction	outward
Opening width	200 mm
DIN stop	left [1]
Dim. Y	14–25 mm

Finish	PU	Order number
Silver	1 pc	K-15166-25-L-1
Brown	1 pc	K-15166-25-L-5
White	1 pc	K-15166-25-L-7

[1] Can be retrofitted from left operation to right operation

Fanlight opening system VENTUS F200

Individual parts – opening stay VENTUS F200



Integral parts

- Stay 1
- Sash bracket
- Guide

Opening stay VENTUS F200

Technical data	
Specifications	with sash bracket
Opening type	Top-Hung window
Opening direction	outward
Opening width	200 mm
DIN stop	left [1]
Dim. Y	26–50 mm

Finish	PU	Order number
Silver	1 pc	K-15166-50-L-1
Brown	1 pc	K-15166-50-L-5
White	1 pc	K-15166-50-L-7



Integral parts

- Stay 1
- Sash bracket
- Guide

Opening stay VENTUS F200

Technical data	
Specifications	with sash bracket
Opening type	Top-Hung window
Opening direction	outward
Opening width	200 mm
DIN stop	left [1]
Dim. Y	51–75 mm

Finish	PU	Order number
Silver	1 pc	K-15166-75-L-1
Brown	1 pc	K-15166-75-L-5
White	1 pc	K-15166-75-L-7

[1] Can be retrofitted from left operation to right operation

Fanlight opening system VENTUS F200

Individual parts – hand lever



Hand lever

Technical data	
Opening type	Bottom-Hung window Top-Hung window
Opening direction Bottom-Hung window	inward
Opening direction Top-Hung window	outward

Finish	PU	Order number
Travel 40 mm		
Silver	1 pc	6-28681-40-0-1
Brown	1 pc	6-28681-40-0-5
White	1 pc	6-28681-40-0-7
Travel 50 mm		
Silver	1 pc	6-28681-50-0-1
Brown	1 pc	6-28681-50-0-5
White	1 pc	6-28681-50-0-7

Fanlight opening system VENTUS F200

Individual parts – hand lever



Lockable hand lever

Technical data	
Opening type	Bottom-Hung window Top-Hung window
Opening direction Bottom-Hung window	inward
Opening direction Top-Hung window	outward

Finish	PU	Order number
Travel 40 mm		
Silver	1 pc	6-32100-40-0-1
Brown	1 pc	6-32100-40-0-5
White	1 pc	6-32100-40-0-7
Travel 50 mm		
Silver	1 pc	6-32100-50-0-1
Brown	1 pc	6-32100-50-0-5
White	1 pc	6-32100-50-0-7

Fanlight opening system VENTUS F200

Individual parts – pivot lever, fixing plate



Pivot lever

Technical data	
Travel	50 mm

Finish	PU	Order number
Silver	1 pc	K-12608-00-0-1
Brown	1 pc	K-12608-00-0-5
White	1 pc	K-12608-00-0-7

Integral parts

- Pivot lever
- Sleeve
- Support
- Rod
- Guide

- Installation drawing 0-44366



Fixing plate

Technical data	
Use	Hand lever lockable hand lever

Finish	PU	Order number
Silver	1 pc	9-33787-00-0-1
Brown	1 pc	9-33787-00-0-5
White	1 pc	9-33787-00-0-7

Fanlight opening system VENTUS F200

Individual parts – sash bracket VENTUS F200



Integral parts

- High sash bracket
- Cover cap

Sash bracket VENTUS F200

Technical data	
Opening type	Bottom-Hung window
Opening direction	inward
Overlap height	0–25 mm

Finish	PU	Order number
Silver	2 pc	K-15225-00-0-1
Brown	2 pc	K-15225-00-0-5
White	2 pc	K-15225-00-0-7



Integral parts

- High sash bracket for hardware groove
- Cover cap

Sash bracket VENTUS F200

Technical data	
Opening type	Bottom-Hung window
Opening direction	inward
Overlap height	0–25 mm

Finish	PU	Order number
Silver	2 pc	K-15225-01-0-1
Brown	2 pc	K-15225-01-0-5
White	2 pc	K-15225-01-0-7

Fanlight opening system VENTUS F200

Individual parts – sash bracket VENTUS F200



16

Integral parts

- Sash bracket with joint
- Cover cap

Sash bracket VENTUS F200 with joint

Technical data	
Window form	Round arch window segmental arch window pitched window
Opening type	Bottom-Hung window Side-Hung window
Opening direction	inward
Overlap height	0–25 mm

Finish	PU	Order number
Silver	1 pc	K-15507-00-0-1
Brown	1 pc	K-15507-00-0-5
White	1 pc	K-15507-00-0-7

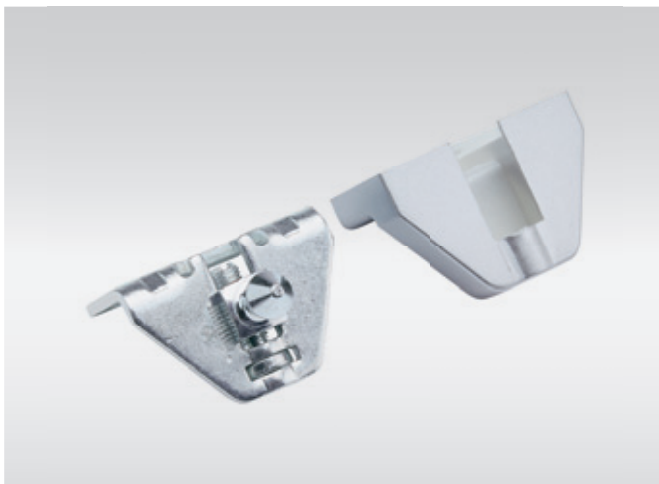

Integral parts

- Short sash bracket
- Cover cap

Sash bracket VENTUS F200

Technical data	
Opening type	Bottom-Hung window
Opening direction	inward
Overlap height	14–25 mm

Finish	PU	Order number
Silver	2 pc	K-15224-00-0-1
Brown	2 pc	K-15224-00-0-5
White	2 pc	K-15224-00-0-7

Fanlight opening system VENTUS F200

Individual parts – sash bracket VENTUS F200

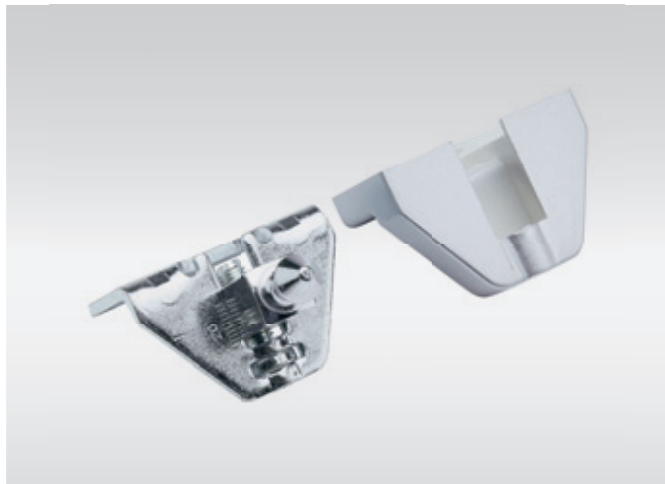

Integral parts

- Short sash bracket for hardware groove
- Cover cap

Sash bracket VENTUS F200

Technical data	
Opening type	Bottom-Hung window
Opening direction	inward
Overlap height	14–25 mm

Finish	PU	Order number
Silver	2 pc	K-15224-01-0-1
Brown	2 pc	K-15224-01-0-5
White	2 pc	K-15224-01-0-7

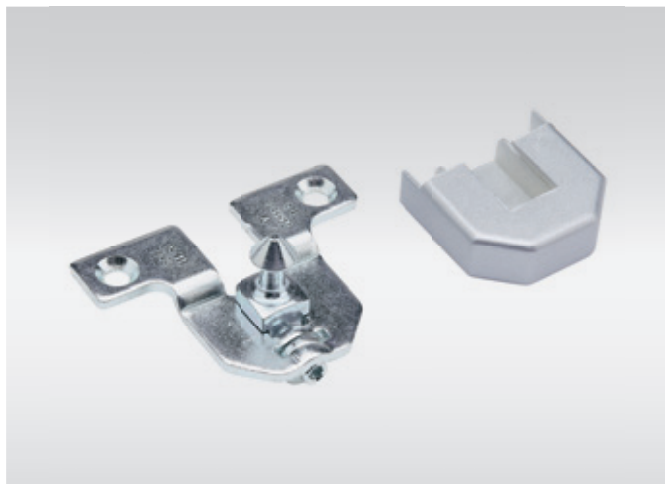

Integral parts

- Flat sash bracket
- Cover cap

Sash bracket VENTUS F200

Technical data	
Opening type	Bottom-Hung window
Opening direction	inward
Overlap height	14–25 mm

Finish	PU	Order number
Silver	2 pc	K-15226-00-0-1
Brown	2 pc	K-15226-00-0-5
White	2 pc	K-15226-00-0-7

Fanlight opening system VENTUS F200

Individual parts – sash bracket



High sash bracket

Technical data	
Opening type	Bottom-Hung window
Opening direction	inward
Overlap height	0–25 mm

Finish	PU	Order number
Silver	1 pc	6-25772-00-0-1



High sash bracket for hardware groove

Technical data	
Opening type	Bottom-Hung window
Opening direction	inward
Overlap height	0–25 mm

Finish	PU	Order number
Silver	1 pc	6-25772-01-0-1

Fanlight opening system VENTUS F200

Individual parts – sash bracket



Sash bracket with joint

Technical data	
Window form	Round arch window segmental arch window pitched window
Opening type	Bottom-Hung window Side-Hung window
Opening direction	inward
Overlap height	0–25 mm

Finish	PU	Order number
Silver	1 pc	6-25830-00-0-1



Short sash bracket

Technical data	
Opening type	Bottom-Hung window
Opening direction	inward
Overlap height	14–25 mm

Finish	PU	Order number
Silver	1 pc	6-28566-00-0-1

Fanlight opening system VENTUS F200

Individual parts – sash bracket



Short sash bracket for hardware groove

Technical data	
Opening type	Bottom-Hung window
Opening direction	inward
Overlap height	14–25 mm

Finish	PU	Order number
Silver	1 pc	6-28566-01-0-1



Flat sash bracket

Technical data	
Opening type	Bottom-Hung window
Opening direction	inward
Overlap height	14–25 mm

Finish	PU	Order number
Silver	1 pc	6-25824-00-0-1

Fanlight opening system VENTUS F200

Individual parts – sash bracket



Sash bracket

Technical data	
Opening type	Top-Hung window
Opening direction	outward

Finish	PU	Order number
Dim. Y = 0–4 mm		
Silver	1 pc	6-27782-04-0-1
Brown	1 pc	6-27782-04-0-5
White	1 pc	6-27782-04-0-7
Dim. Y = 5–25 mm		
Silver	1 pc	6-27782-25-0-1
Brown	1 pc	6-27782-25-0-5
White	1 pc	6-27782-25-0-7
Dim. Y = 26–50 mm		
Silver	1 pc	6-27782-50-0-1
Brown	1 pc	6-27782-50-0-5
White	1 pc	6-27782-50-0-7
Dim. Y = 51–75 mm		
Silver	1 pc	6-27782-75-0-1
Brown	1 pc	6-27782-75-0-5
White	1 pc	6-27782-75-0-7

Fanlight opening system VENTUS F200

Individual parts – cover cap

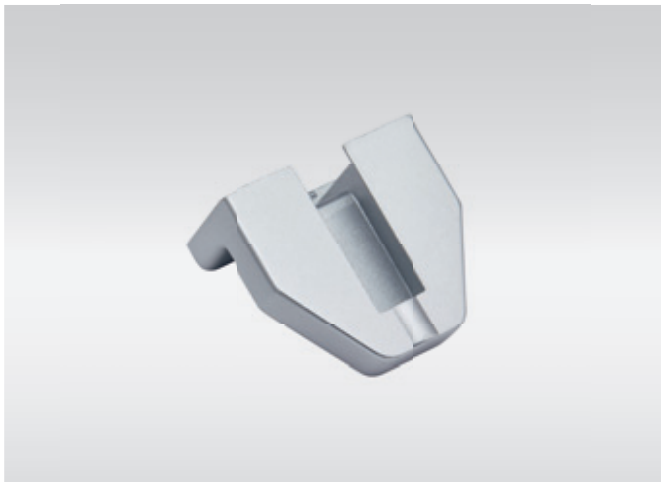

Cover cap

Technical data	
Use	High sash bracket high sash bracket for hardware groove sash bracket with joint
Opening type	Bottom-Hung window
Opening direction	inward
Overlap height	0–25 mm

Finish	PU	Order number
Silver	1 pc	9-33346-01-0-1
Brown	1 pc	9-33346-01-0-5
White	1 pc	9-33346-01-0-7

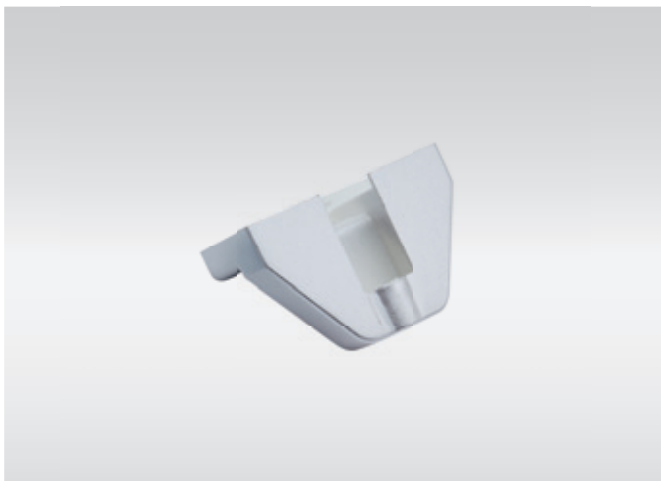

Cover cap

Technical data	
Use	Short sash bracket short sash bracket for hardware groove
Opening type	Bottom-Hung window
Opening direction	inward
Overlap height	14–25 mm

Finish	PU	Order number
Silver	1 pc	9-37313-01-0-1
Brown	1 pc	9-37313-01-0-5
White	1 pc	9-37313-01-0-7

Fanlight opening system VENTUS F200

Individual parts – cover cap

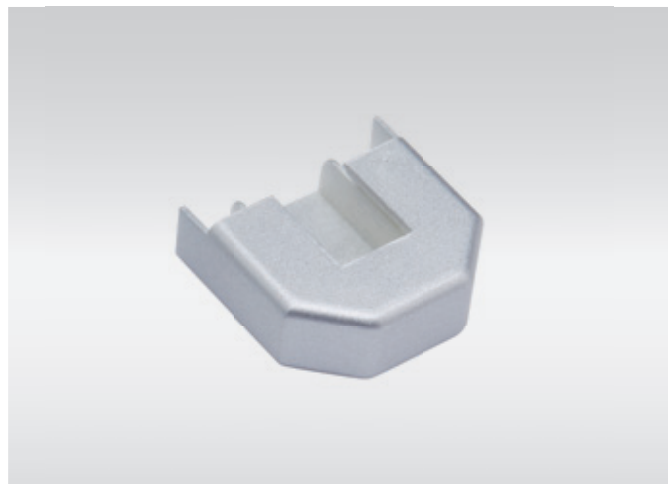

Cover cap

Technical data	
Use	Flat sash bracket
Opening type	Bottom-Hung window
Opening direction	inward
Overlap height	14–25 mm

Finish	PU	Order number
Silver	1 pc	9-33900-00-0-1
Brown	1 pc	9-33900-00-0-5
White	1 pc	9-33900-00-0-7

Fanlight opening system VENTUS F200

Individual parts – bell-shaped angle transmission



Integral parts

- High bell-shaped angle
- Short bell-shaped angle
- Rod
- Fixing plate
- Countersunk screw M5x8
- Countersunk screw M5x6
- Guide

Bell-shaped angle transmission

Technical data	
Opening type	Bottom-Hung window
Opening direction	inward
Recess depth T	150–405 mm

Finish	PU	Order number
Silver	1 pc	K-13730-00-0-1
Brown	1 pc	K-13730-00-0-5
White	1 pc	K-13730-00-0-7

Note: unmounted in as-delivered state



Integral parts

- Guide
- Guide fixing plate
- Countersunk screw M5x8

Guide for bell-shaped angle transmission

Surface	PU	Order number
Silver	1 pc	K-13731-00-0-1
Brown	1 pc	K-13731-00-0-5
White	1 pc	K-13731-00-0-7

Fanlight opening system VENTUS F200

Individual parts – flexible transmission

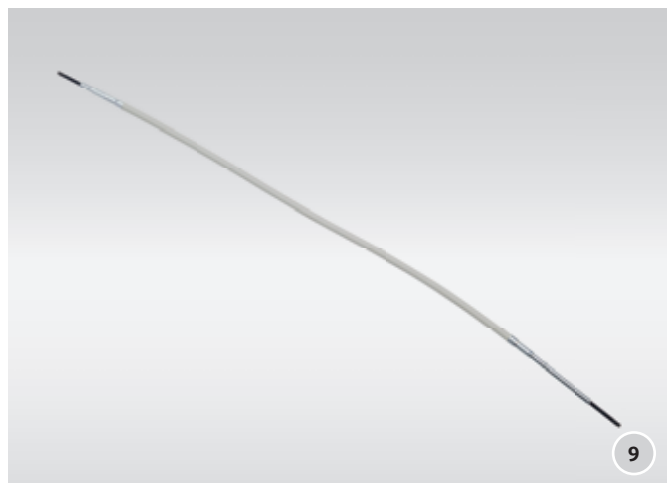

Flexible transmission

Technical data	
Opening type	Bottom-Hung window
Opening direction	inward

Surface	PU	Order number
Length = 200 mm		
Silver	1 pc	6-29495-02-0-1
Brown	1 pc	6-29495-02-0-5
White	1 pc	6-29495-02-0-7
Length = 400 mm		
Silver	1 pc	6-29495-04-0-1
Brown	1 pc	6-29495-04-0-5
White	1 pc	6-29495-04-0-7
Length = 700 mm		
Silver	1 pc	6-29495-07-0-1
Brown	1 pc	6-29495-07-0-5
White	1 pc	6-29495-07-0-7

Finish	PU	Order number
Length = 1000 mm		
Silver	1 pc	6-29495-10-0-1
Brown	1 pc	6-29495-10-0-5
White	1 pc	6-29495-10-0-7
Length = 1300 mm		
Silver	1 pc	6-29495-13-0-1
Brown	1 pc	6-29495-13-0-5
White	1 pc	6-29495-13-0-7
Length = 2000 mm		
Silver	1 pc	6-29495-20-0-1
Brown	1 pc	6-29495-20-0-5
White	1 pc	6-29495-20-0-7

Fanlight opening system VENTUS F200

Individual parts – flexible transmission

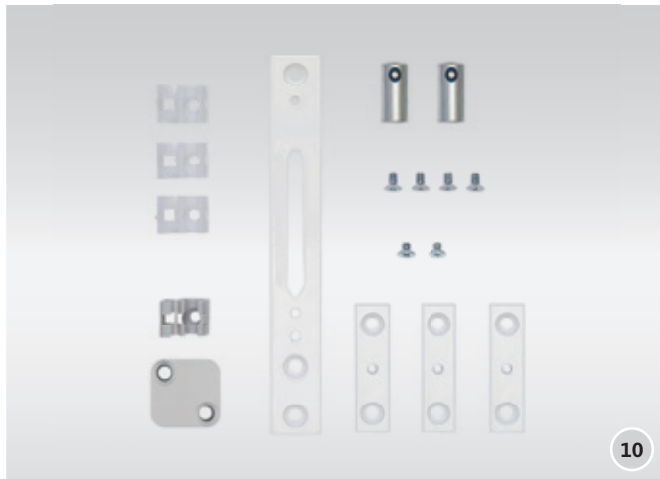

Integral parts

- Sleeve
- 3 x guide Ø 8 mm
- 1 x guide Ø 10 mm
- 3 x fixing plate, small for guide Ø 8 mm
- 1 x large fixing plate for hand lever
- Countersunk screws M5x8
- Countersunk screws M5x6
- Support for flexible transmission

Accessories for flexible transmission

Surface	PU	Order number
Silver	1 pc	K-14312-00-0-1
Brown	1 pc	K-14312-00-0-5
White	1 pc	K-14312-00-0-7

Fanlight opening system VENTUS F200

Individual parts – connecting rod transmission, T angle bracket

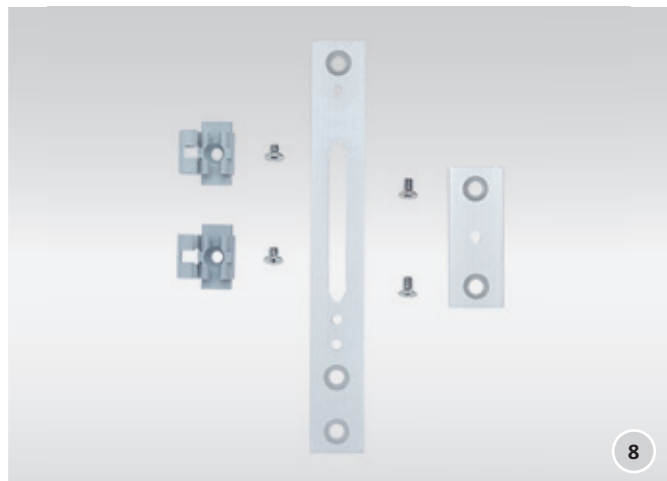

Integral parts

- Guide
- Guide fixing plate
- Fixing plate
- Countersunk screw M5x8
- Countersunk screw M5x6

Additional parts for connecting rod transmission Ø 8 mm

Technical data	
Opening type	Bottom-Hung window
Opening direction	inward
Rod cropping max.	100 mm

Finish	PU	Order number
Silver	1 pc	K-13732-00-0-1
Brown	1 pc	K-13732-00-0-5
White	1 pc	K-13732-00-0-7

Note:

- The 9-25476 connecting rod must be ordered separately (see page 430)
- The cropping of the connecting rod is to be provided by customer.



Integral parts

- Chain with rod clamps
- Rod clamp
- Enclosure with spring dowel pin
- T-angle
- Bowed push/pull handle
- T-cover

T-angle bracket VENTUS F200

Technical data	
Opening type	Bottom-Hung window Side-Hung window
Opening direction	inward

Finish	PU	Order number
Silver	1 pc	K-14194-00-0-1
Brown	1 pc	K-14194-00-0-5
White	1 pc	K-14194-00-0-7

Fanlight opening system VENTUS F200

Individual parts – transom / mullion transmission

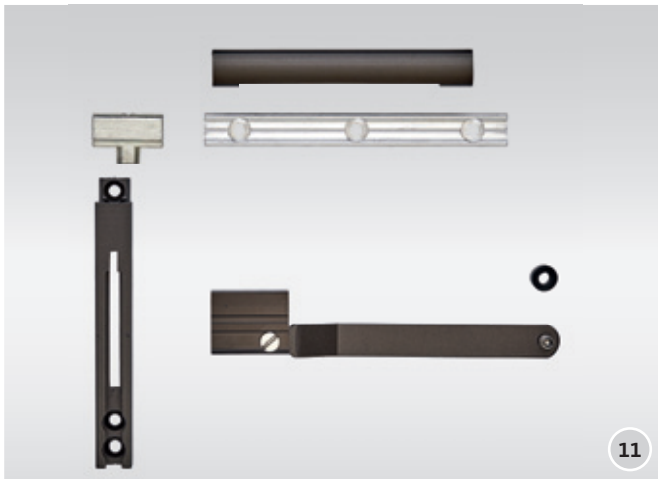

Integral parts

- Mullion transmission
- Guide
- Guide profile
- Striker
- Cover profile
- End cap

Transom / mullion transmission

Technical data	
Opening type	Bottom-Hung window
Opening direction	inward
Rod length L	126 mm
Dimension T (mullion depth)	17-80 mm

Finish	PU	Order number
Silver	1 pc	K-15384-08-0-1
Brown	1 pc	K-15384-08-0-5
White	1 pc	K-15384-08-0-7

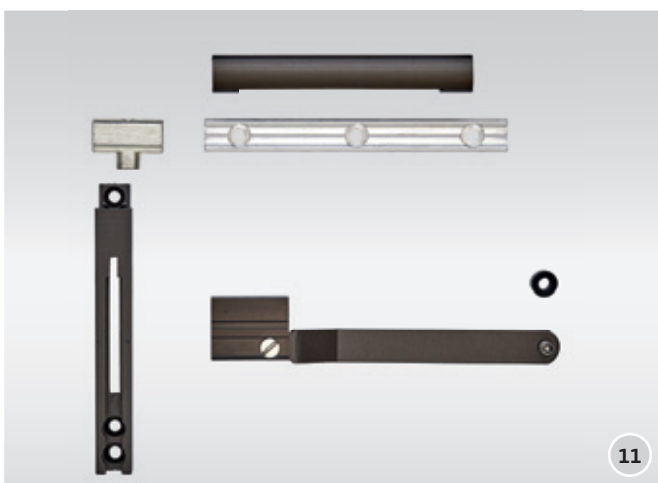

Integral parts

- Mullion transmission
- Guide
- Guide profile
- Striker
- Cover profile
- End cap

Transom / mullion transmission

Technical data	
Opening type	Bottom-Hung window
Opening direction	inward
Rod length L	266 mm
Dimension T (mullion depth)	17-150 mm

Finish	PU	Order number
Silver	1 pc	K-15384-15-0-1
Brown	1 pc	K-15384-15-0-5
White	1 pc	K-15384-15-0-7

Fanlight opening system VENTUS F200

Individual parts – additional lock VENTUS F200



Integral parts

- Corner guide
- Chain with rod clamps
- Striker
- Guide profile
- Striker
- Cover profile
- Guide
- Corner cover

Additional lock VENTUS F200 vertical for timber / PVC windows with overlap

Technical data	
Frame material	Timber PVC
Opening type	Bottom-Hung window
Opening direction	inward
Overlap height	from 16 mm

Surface	PU	Order number
Silver	1 pc	K-15209-00-0-1
Brown	1 pc	K-15209-00-0-5
White	1 pc	K-15209-00-0-7

Fanlight opening system VENTUS F200

Individual parts – additional lock VENTUS F200



Integral parts

- Corner guide
- Chain with rod clamps
- Striker
- Guide profile
- Striker
- Cover profile
- Guide
- Corner cover

Additional lock VENTUS F200 vertical for metal windows with overlap

Technical data	
Frame material	Metal
Opening type	Bottom-Hung window
Opening direction	inward

Finish	PU	Order number
Overlap thickness = 6–7 mm		
Silver	1 pc	K-15210-60-0-1
Brown	1 pc	K-15210-60-0-5
White	1 pc	K-15210-60-0-7
Overlap thickness = 7–8 mm		
Silver	1 pc	K-15210-70-0-1
Brown	1 pc	K-15210-70-0-5
White	1 pc	K-15210-70-0-7
Overlap thickness = 8–9 mm		
Silver	1 pc	K-15210-80-0-1
Brown	1 pc	K-15210-80-0-5
White	1 pc	K-15210-80-0-7
Overlap thickness = 9–10 mm		
Silver	1 pc	K-15210-90-0-1
Brown	1 pc	K-15210-90-0-5
White	1 pc	K-15210-90-0-7

Fanlight opening system VENTUS F200

Individual parts – additional lock VENTUS F200



Integral parts

- Corner guide
- Chain with rod clamps
- Striker
- Guide profile
- Striker
- Cover profile
- Guide
- Corner cover
- Packer plate (not shown)

Additional lock VENTUS F200 vertical for flush metal / timber windows

Technical data	
Frame material	Metal Timber
Opening type	Bottom-Hung window
Opening direction	inward

Finish	PU	Order number
Silver	1 pc	K-15210-01-0-1
Brown	1 pc	K-15210-01-0-5
White	1 pc	K-15210-01-0-7

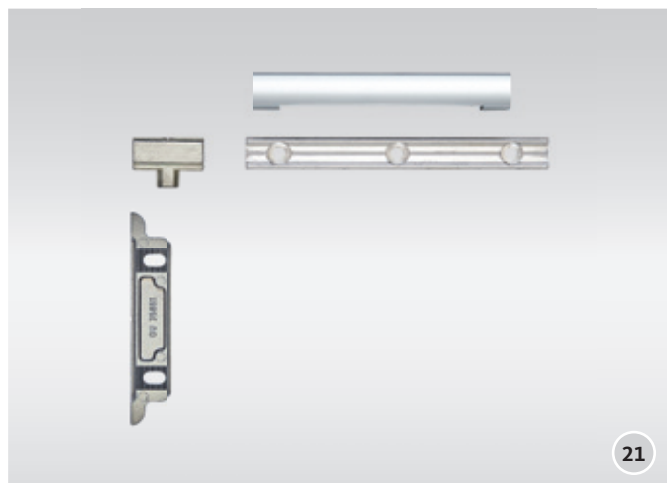

Integral parts

- Striker
- Guide profile
- Striker
- Cover profile

Additional lock VENTUS F200 horizontal for timber / PVC windows with overlap

Technical data	
Frame material	Timber PVC
Window form	Pitched window
Opening type	Bottom-Hung window
Opening direction	inward
Overlap height	from 16 mm

Surface	PU	Order number
Silver	1 pc	K-12008-00-0-1
Brown	1 pc	K-12008-00-0-5
White	1 pc	K-12008-00-0-7

Fanlight opening system VENTUS F200

Individual parts – additional lock VENTUS F200

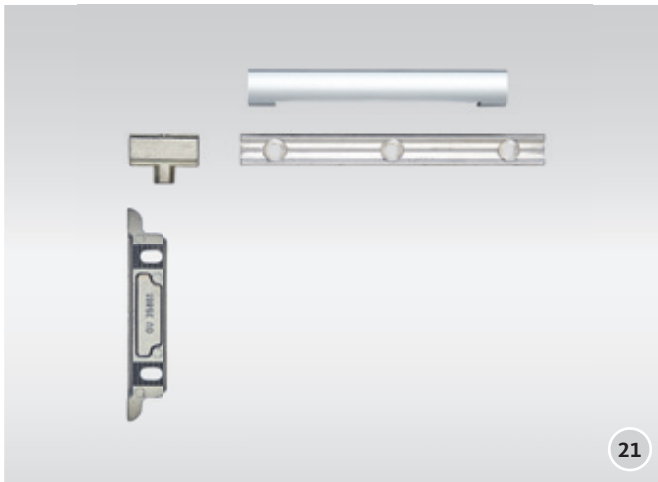

Integral parts

- Striker
- Guide profile
- Striker
- Cover profile

Additional lock VENTUS F200 horizontal for metal windows with overlap

Technical data	
Frame material	Metal
Window form	Pitched window
Opening type	Bottom-Hung window
Opening direction	inward

Finish	PU	Order number
Overlap thickness = 6–7 mm		
Silver	1 pc	K-13033-60-0-1
Brown	1 pc	K-13033-60-0-5
White	1 pc	K-13033-60-0-7
Overlap thickness = 7–8 mm		
Silver	1 pc	K-13033-70-0-1
Brown	1 pc	K-13033-70-0-5
White	1 pc	K-13033-70-0-7
Overlap thickness = 8–9 mm		
Silver	1 pc	K-13033-80-0-1
Brown	1 pc	K-13033-80-0-5
White	1 pc	K-13033-80-0-7
Overlap thickness = 9–10 mm		
Silver	1 pc	K-13033-90-0-1
Brown	1 pc	K-13033-90-0-5
White	1 pc	K-13033-90-0-7

Fanlight opening system VENTUS F200

Individual parts – additional lock VENTUS F200

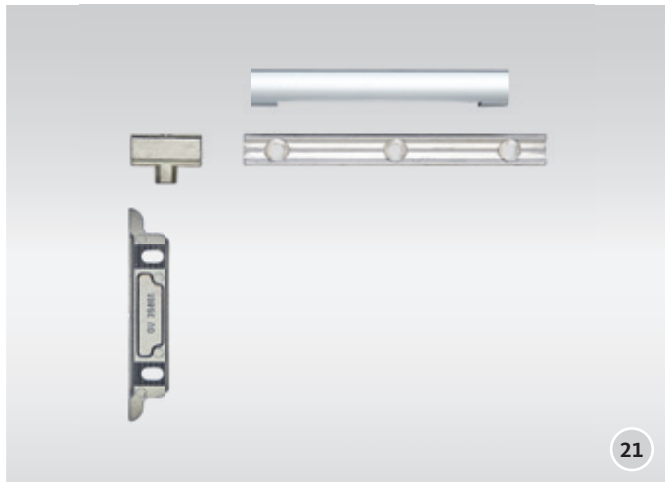

Integral parts

- Striker
- Guide profile
- Striker
- Cover profile

Additional lock VENTUS F200 horizontal for flush metal / timber windows

Technical data	
Frame material	Metal Timber
Window form	Pitched window
Opening type	Bottom-Hung window
Opening direction	inward

Finish	PU	Order number
Silver	1 pc	K-13033-01-0-1
Brown	1 pc	K-13033-01-0-5
White	1 pc	K-13033-01-0-7

Fanlight opening system VENTUS F200

Individual parts – Accessories for round and segmental arch windows

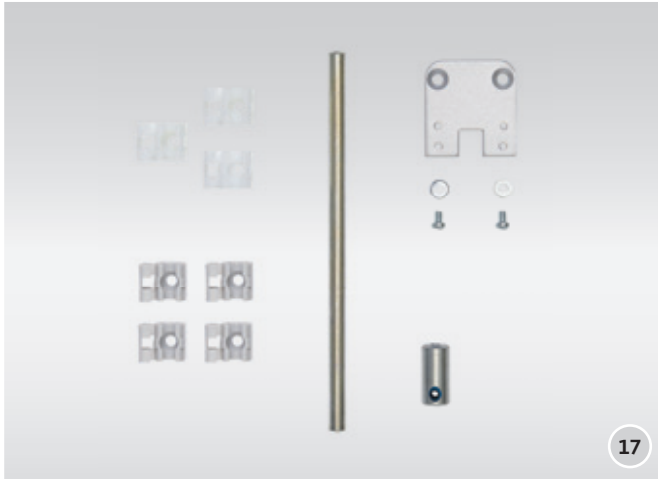

17

Integral parts

- Sleeve
- 3 x guide Ø 8 mm
- 4 x guide Ø 10 mm
- Rod
- Packer
- Disc
- Cylinder head screws M4x6

Accessories for round and segmental arch windows for pattern 1 and pattern 2n

Technical data	
Window form	Round arch window segmental arch window
Opening type	Bottom-Hung window
Opening direction	inward

Finish	PU	Order number
Silver	1 pc	K-15484-00-0-1
Brown	1 pc	K-15484-00-0-5
White	1 pc	K-15484-00-0-7

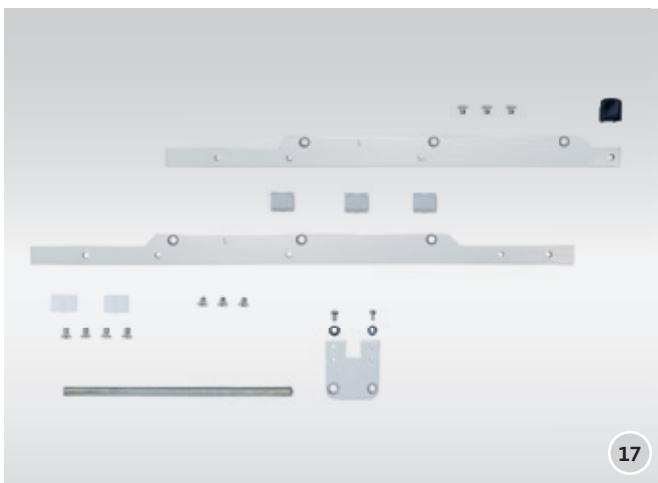

17

Integral parts

- 2 x guide Ø 8 mm
- 3 x guide Ø 10 mm
- Rod
- Packer
- Disc
- Fixing plates
- End cap
- Cylinder head screws M4x6
- Countersunk screws M5x6
- Countersunk screws M5x8

Accessories for round and segmental arch windows for pattern 2n

Technical data	
Window form	Round arch window segmental arch window
Opening type	Bottom-Hung window
Opening direction	inward

Finish	PU	Order number
Silver	1 pc	K-15485-00-0-1
Brown	1 pc	K-15485-00-0-5
White	1 pc	K-15485-00-0-7

Fanlight opening system VENTUS F200

Individual parts – vertical and corner drive-gear



23

Integral parts

- Vertical gear
- Lift stop
- Universal joint gear
- Threaded pin
- Conical notched pin
- Rod

Vertical gear

Technical data	
Opening type	Bottom-Hung window Top-Hung window
Opening direction Bottom-Hung window	inward
Opening direction Top-Hung window	outward
Travel	40 mm / 50 mm

Surface	PU	Order number
Silver	1 pc	K-13402-00-0-1



29

Integral parts

- Bearings
- Double universal joint
- Threaded pin
- Cover cap

Additional parts for corner drive-gear

Technical data	
Opening type	Bottom-Hung window Top-Hung window
Opening direction Bottom-Hung window	inward
Opening direction Top-Hung window	outward

Finish	PU	Order number
Silver	1 pc	K-13403-00-0-1
Brown	1 pc	K-13403-00-0-5
White	1 pc	K-13403-00-0-7

Fanlight opening system VENTUS F200

Individual parts – vertical and corner drive-gear



Crank rod

Technical data	
Opening type	Bottom-Hung window Top-Hung window
Opening direction Bottom-Hung window	inward
Opening direction Top-Hung window	outward
Rod material	Aluminium

Surface	Length	PU	Order number
Silver	1055 mm	1 pc	9-32230-10-0-1
White	1055 mm	1 pc	9-32230-10-0-7
Silver	5000 mm	1 pc	9-32230-50-0-1
Brown	5000 mm	1 pc	9-32230-50-0-5
White	5000 mm	1 pc	9-32230-50-0-7



Load-limiting device

Technical data	
Use	Crank
Release torque	approx. 4 Nm

Finish	PU	Order number
Silver	1 pc	6-31245-00-0-1

Fanlight opening system VENTUS F200

Individual parts – vertical and corner drive-gear



Articulated crank

Surface	PU	Order number
Silver	1 pc	K-13162-00-0-1
Brown	1 pc	K-13162-00-0-5
White	1 pc	K-13162-00-0-7

Integral parts

- Articulated crank
- Crank clip
- Conical notched pin



Universal joint

Technical data	
Opening type	Bottom-Hung window Top-Hung window
Opening direction Bottom-Hung window	inward
Opening direction Top-Hung window	outward

Finish	PU	Order number
Silver	1 pc	K-13164-00-0-1

Integral parts

- Crank rod universal joint
- Crank rod guide
- Conical notched pin

Fanlight opening system VENTUS F200

Individual parts – vertical and corner drive-gear



Coupling bush

Technical data	
Opening type	Bottom-Hung window Top-Hung window
Opening direction Bottom-Hung window	inward
Opening direction Top-Hung window	outward

Finish	PU	Order number
Silver	1 pc	K-13165-00-0-1

Integral parts

- Coupling bush
- Conical notched pin



Telescopic spindle drive

Technical data	
Travel	300 mm
Gear length	222 mm

Finish	PU	Order number
Silver	1 pc	6-24869-00-0-1

Note:

- Installation drawing 0-40636
- Only in combination with crank rod 9-32230 (page 425), articulated crank K-13162 (page 426) and coupling bush K-13165 (page 427)

Fanlight opening system VENTUS F200

Individual parts – dog VENTUS F200

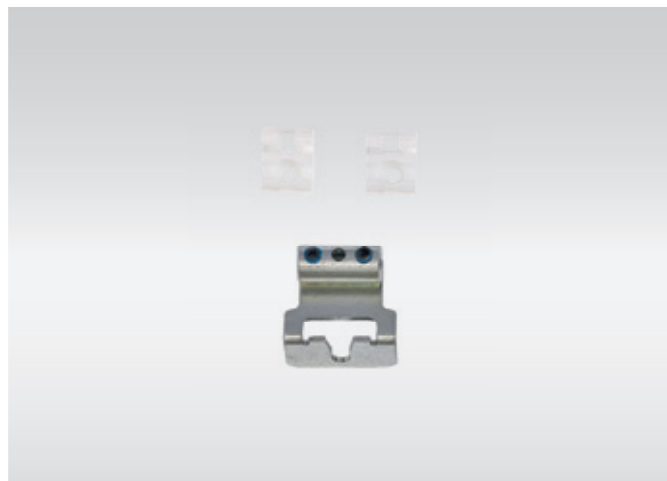

VENTUS F200 dog for JET CLS

Note:

- Installation drawing 16 mm hardware groove: 0-43813
- Installation drawing Euro-groove 15/20: 0-48594
- Cover profile 9-39509 must be ordered separately (page 429)

Integral parts

- Dog for JET CLS
- Guide

Window form	Rebate system	Overlap height	Axis	PU	Order number
Rectangular window (Distance between axes 12 mm)	16 mm hardware groove	18 mm	9 mm	1 pc	K-19765-01-0-1
	16 mm hardware groove Euro-groove 15/20	18 mm	9 mm 13 mm	1 pc	K-19765-02-0-1
	16 mm hardware groove	20–22 mm	9 mm 13 mm	1 pc	K-19765-03-0-1
Pitched window (Distance between axes 17 mm)	16 mm hardware groove	18 mm	9 mm	1 pc	K-19765-11-0-1
	16 mm hardware groove Euro-groove 15/20	18 mm	9 mm 13 mm	1 pc	K-19765-12-0-1
	16 mm hardware groove	20–22 mm	9 mm 13 mm	1 pc	K-19765-13-0-1

Fanlight opening system VENTUS F200

Individual parts – cover profile

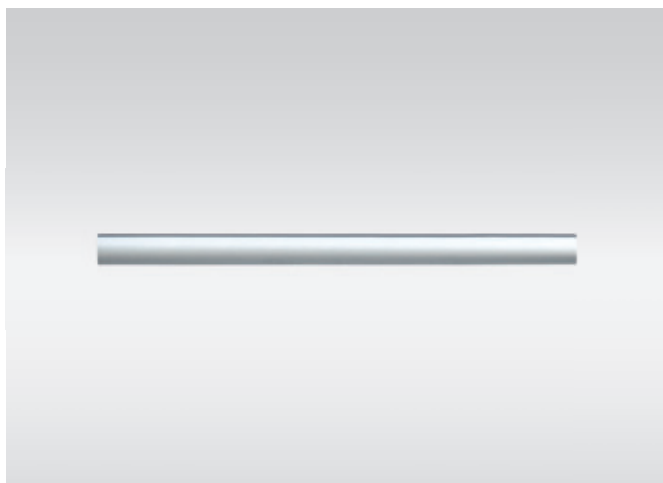

Cover profile

Technical data	
Use	VENTUS F200 dog for JET CLS

Finish	PU	Order number
Silver	1 pc	9-39509-00-0-1
Brown	1 pc	9-39509-00-0-5
White	1 pc	9-39509-00-0-7

Fanlight opening system VENTUS F200

Individual parts – connecting rod and horizontal rod



Connecting rod and horizontal rod Ø 8 mm

Technical data	
Opening type	Bottom-Hung window Top-Hung window
Opening direction Bottom-Hung window	inward
Opening direction Top-Hung window	outward
Diameter	8 mm

Finish	PU	Order number
Length = 600 mm		
Silver	1 pc	9-25476-06-0-1
Length = 1850 mm		
Silver	1 pc	9-25476-18-0-1
Length = 3300 mm		
Silver	1 pc	9-25476-33-0-1
Length = 6000 mm		
Silver	1 pc	9-25476-60-0-1

Fanlight opening system VENTUS F200

Individual parts – cover profile



Cover profile

Technical data	
Use	Connecting rod and horizontal rod Ø 8 mm
Opening type	Bottom-Hung window Top-Hung window
Opening direction Bottom-Hung window	inward
Opening direction Top-Hung window	outward

Finish	PU	Order number
Length = 62 mm		
Silver	5 pc	9-33444-01-0-1
Brown	1 pc	9-33444-01-0-5
White	1 pc	9-33444-01-0-7
Length = 800 mm		
Silver	5 pc	9-33444-06-0-1
Brown	1 pc	9-33444-06-0-5
White	5 pc	9-33444-06-0-7
Length = 1800 mm		
Silver	5 pc	9-33444-18-0-1
Brown	5 pc	9-33444-18-0-5
White	5 pc	9-33444-18-0-7

Finish	PU	Order number
Length = 3050 mm		
Silver	5 pc	9-33444-33-0-1
Brown	5 pc	9-33444-33-0-5
White	5 pc	9-33444-33-0-7
Length = 6000 mm		
Silver	5 pc	9-33444-60-0-1
Brown	5 pc	9-33444-60-0-5
White	5 pc	9-33444-60-0-7

Fanlight opening system VENTUS F200

Individual parts - end cap, end cover

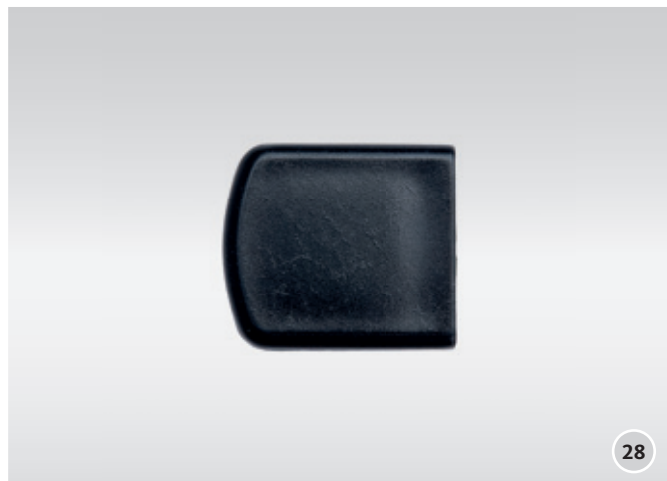

28

End cap

Technical data	
Use	Cover profile

Finish	PU	Order number
Black	1 pc	9-34412-00-0-6
White	1 pc	9-34412-00-0-7



39

Corner cover

Technical data	
Use	Corner guide





Finish	PU	Order number
Black	1 pc	9-34220-00-0-6
White	1 pc	9-34220-00-0-7

Fanlight opening system VENTUS F200

Individual parts – guide, sleeve





Guide

Surface	PU	Order number
Diameter 8 mm		
Untreated	1 pc	9-28893-00-0-0 
Diameter 10 mm		
Untreated	1 pc	9-35366-00-0-0 
Brown	1 pc	9-35366-00-0-5 
White	1 pc	9-35366-00-0-7 



Sleeve

Surface	PU	Order number
Diameter 8 mm		
Silver	1 pc	6-22842-00-0-1 
Diameter 8 mm / M5		
Silver	1 pc	6-27402-00-0-1 

Fanlight opening system VENTUS F200

Individual parts – pitched corner angle, enclosed sash bracket



Pitched corner angle

Technical data	
Opening type	Bottom-Hung window
Opening direction	inward

Finish	PU	Order number
Silver	1 pc	6-23796-00-0-1

Enclosed sash bracket

Technical data	
Opening type	Bottom-Hung window
Opening direction	inward
Finish	silver

Frame material	PU	Order number
Timber	1 pc	9-34508-00-0-0
PVC	1 pc	9-33105-00-0-1









Fanlight opening system VENTUS F200







Individual parts – drilling jigs



Drilling jig VENTUS F200

Use	Opening type	Overlap min.	Overlap max.	Drilling diameter	PU	Order number
Timber and PVC windows						
High sash bracket Low sash bracket	Bottom-Hung window	–	16 mm	3 mm 5.2 mm	1 pc	6-29410-30-0-9 
High sash bracket Low sash bracket	Bottom-Hung window	16 mm	–	3 mm 5.2 mm	1 pc	6-33234-30-0-9 
Flat sash bracket	Bottom-Hung window	–	16 mm	3 mm	1 pc	6-29411-00-0-9 
Flat sash bracket	Bottom-Hung window	16 mm	–	3 mm	1 pc	6-33235-00-0-9 
Metal windows with overlap						
High sash bracket Low sash bracket	Bottom-Hung window	–	16 mm	3 mm 5.2 mm	1 pc	6-29410-35-0-9 
High sash bracket Low sash bracket	Bottom-Hung window	16 mm	–	3 mm 5.2 mm	1 pc	6-33234-35-0-9 

Drilling jig VENTUS F200 for coupling

Use	Opening type	Overlap min.	Overlap max.	Drilling diameter	PU	Order number
Timber and PVC windows						
High sash bracket Low sash bracket	Bottom-Hung window	–	16 mm	3 mm 5.2 mm	1 pc	6-29474-01-0-9 
Flat sash bracket	Bottom-Hung window	–	16 mm	3 mm	1 pc	6-29474-02-0-9 
High sash bracket Low sash bracket	Bottom-Hung window	16 mm	–	3 mm 5.2 mm	1 pc	6-33236-01-0-9 
Flat sash bracket	Bottom-Hung window	16 mm	–	3 mm	1 pc	6-33236-02-0-9 
Metal windows with overlap						
High sash bracket Low sash bracket	Bottom-Hung window	–	16 mm	3 mm 5.2 mm	1 pc	6-29474-03-0-9 
High sash bracket Low sash bracket	Bottom-Hung window	16 mm	–	3 mm 5.2 mm	1 pc	6-33236-03-0-9 

Fanlight opening system VENTUS F200

Individual parts – drilling jigs



Drilling jig

Use	Opening type	Opening direction	PU	Order number
High sash bracket for hardware groove Short sash bracket for hardware groove	Bottom-Hung window	inward	1 pc	6-33615-00-0-1
Sash bracket with joint	Bottom-Hung window	inward	1 pc	6-29650-00-0-1
Round and segmental arch windows Pattern 1	Bottom-Hung window	inward	1 pc	9-39659-00-0-0
Additional lock vertical Additional lock horizontal	Bottom-Hung window	inward	1 pc	9-29311-00-0-1
Pivot lever	Bottom-Hung window Top-Hung window	inward outward	1 pc	9-30911-00-0-1
Articulated crank rod	Bottom-Hung window Top-Hung window	inward outward	1 pc	6-22276-00-0-0
Corner drive-gear Hole diameter 3.0 mm	Bottom-Hung window Top-Hung window	inward outward	1 pc	6-25841-02-0-0
Corner drive-gear Hole diameter 3.5 mm	Bottom-Hung window Top-Hung window	inward outward	1 pc	6-25841-03-0-0
Opening stay and sash bracket Dim. Y = 0–40 mm	Top-Hung window	outward	1 pc	6-29490-00-0-0
Sash bracket Dim. Y = 41–75 mm	Top-Hung window	outward	1 pc	6-29583-00-0-0

GU restrictor and cleaning stay EURO-SOLID

For timber, PVC and metal windows



GU restrictor and cleaning stay EURO-SOLID

Technical data	
Opening type	Bottom-Hung window
Opening direction	inward
Frame material	Timber PVC Metal

size	PU	Order number
01	10 pc	6-27995-01-0-8
02	20 pc	6-27995-02-0-8
03	20 pc	6-27995-03-0-8
04	20 pc	6-27995-04-0-8

Note:

- For compliance with the RAL directives, it is absolutely necessary that, in addition to the standard fanlight hardware, Bottom-Hung sashes be fitted with restrictor stays.
- The GU restrictor and cleaning stays prevent damage that could occur due to improper hinging of the opening stays. Moreover, they provide ideal convenience for cleaning because the sash is held in the required position.

Size	Min. sash height	Max. sash height	Opening angle with min. restrictor position	Opening angle with max. restrictor position	Max. sash weight per stay
01	270 mm	350 mm	–	30°	15 kg
02	351 mm	500 mm	40°	45°	15 kg
03	501 mm	800 mm	25°	30°	30 kg
04	801 mm	1500 mm	15°	20°	30 kg

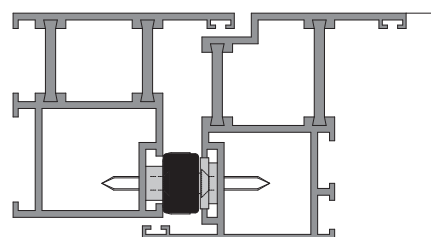
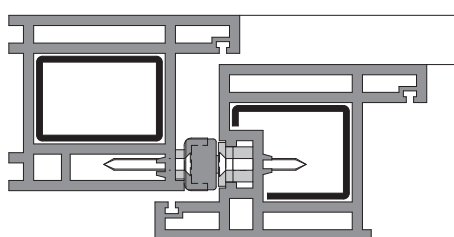
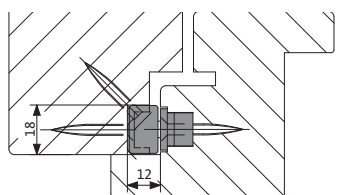

GU restrictor and cleaning stay EURO-SOLID

Accessories



Drilling jig set for frame and sash

Technical data	
Use	EURO-SOLID restrictor and cleaning stay

	PU	Order number
	1 pc	K-14788-00-0-0

Packer for Euro-groove 7/8x4, 6/8x4 / timber

	PU	Order number
	20 pc	9-38819-00-0-1

Profile accessories for timber Bottom-Hung windows

	PU	Order number
	20 pc	K-14681-00-0-1

Note:

- For PVC and metal Bottom-Hung windows on request





4.0 Additional information

The complete SHEV system as a one-stop service

Functional principle of a SHEV system	444
Components of a SHEV system	445
Smoke and heat exhaust ventilation systems as an essential part of preventative fire protection	446
Definition of terms	447
DIN 18232, Model Building Regulation, regional building regulations	450
Planning – selecting the drive system	452
Planning – Selection of the suitable SHEV central control unit	462
Protection classes (IP) according to DIN 60529	466
Duty ratio (ED) according to DIN VDE 0530-1	467
Wind strengths according to Beaufort	467
Essential information for installers and planners	468
Building Rules List	471
List of abbreviations	472

The complete SHEV system as a one-stop service

Security with a system

The smoke emitted by fires represents the greatest threat to people and the building. For this reason, it is extremely important that the smoke be extracted quickly and reliably. In this case, smoke and heat exhaust ventilation systems, as a fixed integral part of preventive fire protection, take over the most important task, namely discharging combustion gases, dangerous oxides and thermal energy outdoors in event of fire. In this way escape and rescue routes are kept virtually free from smoke, thus allowing active and passive rescue. Furthermore, this avoids the thermal load imposed on the building structure by hot fire gases leading to damage to the building. We offer you a large range of mutually coordinated system components – from electrically driven chain and spindle drives to SHEV central control systems and extending to an extensive accessory programme.





Functional principle of a SHEV system



SHEV systems essentially consist of the system components seen in the system design on the left. They cover two large areas of responsibility: emergency situations and everyday ventilation.

SHEV systems from the Gretscht-Unitas group are used for the everyday ventilation of rooms as well as smoke exhaust in the event of a fire. In this case the dissipation of smoke and heat is controlled by the electric control unit (SHEV central control unit). Windows, smoke flaps and light domes are opened or closed by electric drives.

The ventilation function is controlled via a ventilation push-button, rain/wind controller or time switch, and in the event of an emergency it is controlled manually via a SHEV push-button or automatically via smoke or heat detectors. In addition, optional alarm signals can also be connected.

Fig.: Keeping escape and rescue routes clear from smoke on the basis of thermal uplift – with supply air openings in the lower wall area and exhaust air openings in the upper wall or ceiling area.

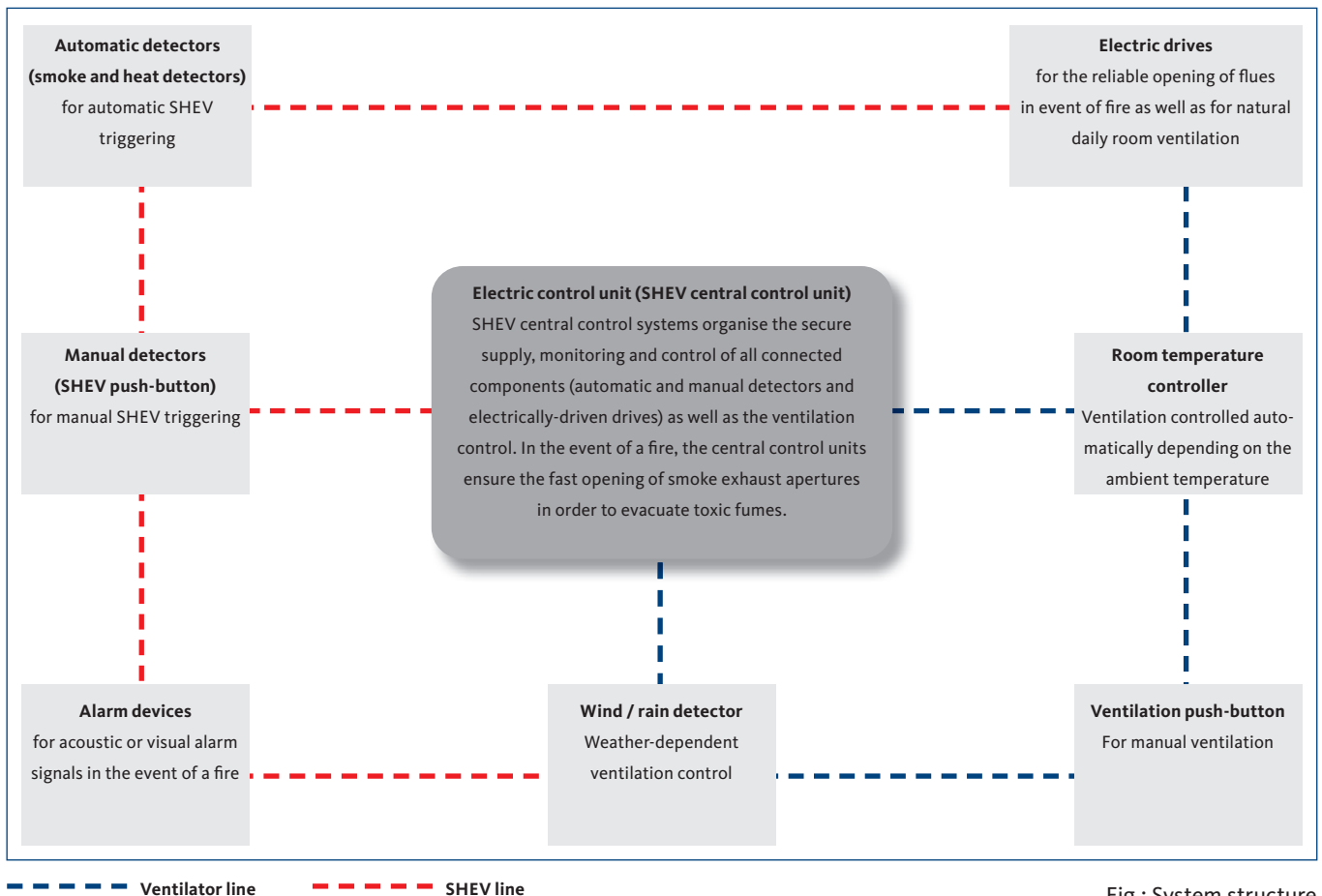

Fig.: System structure

Components of a SHEV system

- Electric control device (SHEV central control unit)
- Electromechanical drives
- SHEV push-button for manual alarm triggering
- Smoke/heat detectors for automatic alarm triggering*
- Alarm devices*

Additional components for the ventilation function

Further components should be selected if the system is also to be used for ventilation, e.g.:

- Room temperature controller
- Wind / rain detector
- Ventilation push-button

* The use of smoke or heat detectors or alarm devices is not mandatory in legislation, however we do recommend it.

Smoke and heat exhaust ventilation systems as an essential part of preventative fire protection



What is meant by preventative and defensive fire protection?

Preventative fire protection

For the protection of the life and health of humans and animals, the development and spreading of fire and smoke should be eliminated or reduced in advance.

According to the definition, this involves measures for preventing the outbreak and spread of fire as well as ensuring that the escape routes are safe.

Defensive fire protection

This refers especially to all measures implemented by the fire brigade for the rescue of humans and animals via secured routes that are necessary in the event of progressive fire.

Smoke and heat exhaust ventilation systems as part of preventative fire protection

Smoke and heat exhaust ventilation systems as an important component of the preventative fire protection concept

Fires and the associated heat and smoke development are still the biggest threat to people and buildings. Every year, many people die in fire disasters, fires also cause enormous property damage. However, the threat to people and buildings not only comes from fire and heat, but especially from smoke and the arising toxic fumes.

For this reason, it is extremely important that the smoke be extracted quickly and reliably. In this case, smoke and heat vent systems, as a fixed integral part of fire prevention, take over the most important task, namely discharging combustion gases, dangerous oxides and thermal energy outdoors in event of fire. In this way, smoke levels are kept low in escape and rescue routes, thereby permitting non-assisted and assisted rescue to take place!

Furthermore, this avoids the thermal load imposed on the building structure by hot fire gases leading to damage to the building.

Protection targets of a smoke and heat exhaust ventilation system

Preventative fire protection does not fully guarantee the prevention of fires in buildings. However, it is possible to achieve protection targets through the use of smoke and heat exhaust ventilation systems.

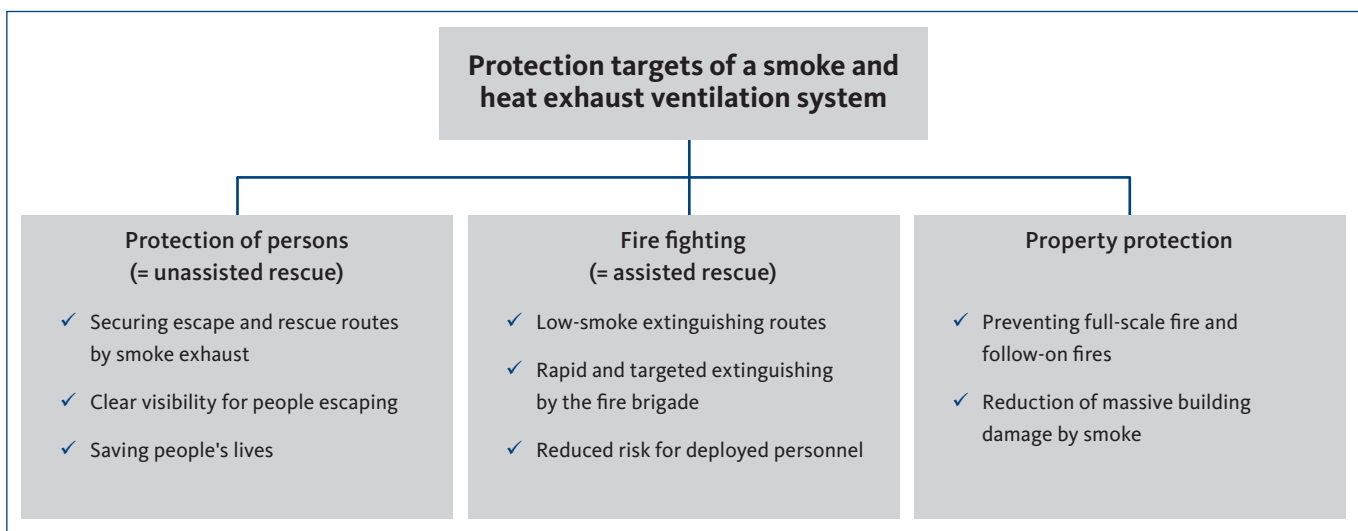



The umbrella term SHEV stands for "smoke and heat exhaust ventilation". This comprises

- a natural smoke exhaust system (NSE)
- a mechanical smoke exhaust system (MRA)
- a smoke protection pressure system (SPS) or
- a lift shaft smoke exhaust system

The term NSE stands for Natural smoke exhaust. A natural smoke exhaust system is defined as a master key system whose function is based on the principle of thermal uplift.

The principle of thermal uplift

In the event of a fire, thermal uplift causes the smoke and fumes in the building to rise upwards and form a layer of smoke gas beneath the ceiling, which fills the entire room within a very short time. Smoke and heat is able to escape through the use of smoke outlets in the upper area of the facade or in the roof. Supply air inlets in the lower area help to boost the thermal uplift.

Smoke and heat exhaust ventilation

Smoke exhaust refers to the extraction of smoke in the event of a fire (heat extraction), in order to create a low-smoke layer near the ground and thus enable the safe use of escape and rescue routes.

The products used here are safety-relevant building products that are regulated by EN 12101-2 in Building Rules List B, part 1. In these cases, NSHEV are required as part of SHEV.

Areas of application:

- Public assembly places
- Large warehouses
- Industrial buildings

The Gretsich-Unitas group offers the latest electromotor-driven SHEV technology relating to natural smoke exhaust (NSE) for all areas of application: from stairwell smoke exhaust to complex SHEV systems for large projects.

NSE systems from the Gretsich-Unitas group ensure the safe, automatic opening of smoke exhaust apertures. As part of the preventative fire protection concept, they minimise the development of smoke in escape and rescue routes, thus protecting people from smoke intoxication and property from damage.

In everyday operation, they also ensure the controlled supply of fresh air.

Smoke ventilation

Smoke exhaust systems in stairwells are referred to as smoke ventilation. Their purpose is to extract smoke by way of cold smoke exhaust.

The products used here are non-safety-relevant building products that are therefore only listed in Building Rules List C, part 3.10.

Planning takes place in accordance with the specifications of the respective applicable regional building regulation (LBO). Decisive are the location, size and opening width of the smoke extraction areas as well as the number and location of the automatic and manual trigger devices

Areas of application:

- Stairwells

What is meant by SHEV?

What is meant by NSE?

What is meant by smoke and heat exhaust ventilation system or smoke extraction?

Definition of terms



What is meant by SHEV group and ventilation group?

SHEV group

A SHEV group consists of at least one alarm line (manual detectors) and a ventilation line (drive line). These two lines together form a SHEV group that refers to a fire compartment (e.g. stairwell). For EMERGENCY OPEN, all connected electro-motor drives are considered as part of this SHEV group.

Up to four mutually independent SHEV groups can be achieved according to the central control system versions.

Ventilation group

A ventilation group consists of several window units (drive lines), which can be opened manually or automatically for everyday room ventilation, regardless of the SHEV group and via a ventilation push-button, rain/wind controller or time switch.

This allows several ventilation groups to be combined in a SHEV group, which open the exhaust and supply air elements automatically in the event of an alarm.

What is meant by dead man's switch function?

In case of ventilation, the drives only move in the opening and/or closing direction as long as the ventilation push-button is activated permanently. If the push-button is no longer activated (pressed), the drives stop their movement. This allows for customised window opening widths.

The main application areas for a dead man's function are windows installed in the gripping area.

All central control units from the Gretsch-Unitas group have a dead man's switch function that can be switched on or off (via DIP switch).

What is meant by runtime limitation?

For ventilation, adjustable limitation of the drive running time (opening width limitation) in the opening direction. In the event of a fire, the running time limitation is deactivated and the drives are fully opened.

This function is integrated in all central control units of the Gretsch-Unitas group as standard and can be individually adjusted via potentiometer.

What is meant by automatic ventilation CLOSED?

The automatic ventilation CLOSED allows the windows to close automatically following the expiry of a predefined time period.

This function is integrated in all central control units of the Gretsch-Unitas group as standard and can be individually adjusted via potentiometer.



Fire alarm system (FAS)

A security alarm which is permanently installed in the building for early detection and direct reporting (emergency call) of fires to the fire brigade.

Furthermore, the FAS can control further technical systems, e.g. a SHEV system or receive signals from this system.

What is meant by FAS?

The option to choose the running direction of the drives in the event of an alarm. In a normal situation with a SHEV alarm, the SHEV openings in the building are opened to extract the smoke from the escape routes.

In rare cases, it may be a requirement that the SHEV openings can be securely shut. In such cases, it is possible to reverse the running direction of the drives via an integrated switch.

What is meant by selection of the running direction?

The reset push-button allows an alarm to be reset remotely, i.e. closes the SHEV openings.

This function is integrated in all central control units of the Gretsche-Unitas group and is controlled via the SHEV push-button.

What is meant by reset function?

DIN 18232, Model Building Regulation, regional building regulations



Collection E+ / Getty Images



To ensure that SHEV systems can be planned and implemented in line with the applicable standards and regulations right from the start, on the following pages we have compiled and briefly explained all the important information about regulations, ordinances and German and European standards.

A wide range of directives and regulations must be observed for the smoke and heat exhaust ventilation system.

According to the building, e.g. for the stairwell, the relevant state building regulation (LBO) must be observed for industrial buildings if it has been adopted by the building supervision authorities of the relevant federal state, the industrial building directive and additionally DIN 18232, for salesrooms, the salesroom directive and additionally DIN 18232 etc. must be observed.

The applicable regulations and guidelines are listed below.

DIN 18232, Part 2

The planning, dimensioning and installation (position and size of the smoke exhaust apertures or supply air apertures) of natural smoke exhaust systems are determined by many national codes of practice as in the past – in Germany by the DIN 18232, part 2 standard.

This standard can be used to determine how many smoke exhaust or supply air apertures should be planned into the facade and where these should be located.

This must be done by the planner or the accepting party.

In general, the planning and configuration should always be carried out in consultation with the local fire protection authorities.

Model Building Regulation (MBO)

„Building structures must be constructed in such a way that the development of a fire and the spreading of fire and smoke is prevented and the rescue of humans and animals as well as effective fire-fighting operations in the event of fire are possible.“

The installation of smoke exhaust systems is one of the most important measures for ensuring the active and passive rescue of persons.

The general requirements of the MBO are adopted by the regional building regulations and specified through further requirements in the legal text of the respective regional building regulation and its supplementary provisions for special structures. The special building regulations of each state are also based on a respective model building regulation. Furthermore, both private guidelines and those governed by public law apply.

Regional building regulations (LBOs)

Smoke exhaust in stairwells

In the respective regional building regulations (LBO), the German Federal States stipulate that stairwells must be fitted with a smoke exhaust system, smoke exhaust device or an opening for removing smoke from the building.

The specifications vary from state to state and are therefore not regulated in a standardised manner.

DIN 18232, Model Building Regulation, regional building regulations



You can find the most recent model ordinances and directives as well as decrees of the "Bauministerkonferenz" for the areas of construction supervision and building technology as well as the land-specific ordinances in the online service portal of the Federal States.

Below you can see an overview of the various regulations of the individual German Federal States concerning smoke extraction in stairwells.

Federal State	Smoke ventilation – when?	Smoke ventilation – where?	Smoke ventilation – size?	Control points where?
Model Building Regulation (MBO)	In necessary stairwells of buildings with heights of more than 13 m or interior, necessary stairwells	At the top point of the stairwell	With a free cross-section of at least 1 m ²	Ground floor (EG) and top stair landing
Baden-Württemberg	More than 5 floors above ground and for interior, necessary stairwells	At the top point; windows may be designed as smoke exhausts if they are situated high enough [1]	With a free cross-section of at least 1 m ²	To be opened from the ground floor (EG) [2]
Bavaria	In necessary stairwells of buildings with heights of more than 13 m or interior, necessary stairwells	At the top point of the stairwell	With a free cross-section of at least 1 m ²	Ground floor and highest landing
Berlin	In necessary stairwells of buildings with heights of more than 13 m or interior, necessary stairwells	At the top point of the stairwell	With a free cross-section of at least 1 m ²	Ground floor and highest landing
Brandenburg	More than 5 floors above ground and for interior, necessary stairwells	At the top point of the stairwell	With a free cross-section of at least 5% of the surface area, at least 1 m ²	Ground floor and highest landing
Bremen	More than 5 floors above ground and for interior, necessary stairwells	At the top point of the stairwell	With a free cross-section of at least 5% of the surface area, at least 1 m ²	Ground floor and highest landing [2]
Hamburg	In necessary stairwells of buildings with heights of more than 13 m or interior, necessary stairwells	At the top point of the stairwell	With a free cross-section of at least 1 m ²	Ground floor and highest landing
Hessen	More than 5 floors above ground and for interior, necessary stairwells	At the top point of the stairwell	With a free cross-section of at least 1 m ²	Ground floor and highest landing
Mecklenburg-Vorpommern	In necessary stairwells of buildings with heights of more than 13 m or interior, necessary stairwells	At the top point of the stairwell	With a free cross-section of at least 1 m ²	Ground floor and highest landing
Niedersachsen	More than 6 floors	At the top point of the stairwell	With a free cross-section of at least 5% of the surface area, at least 1 m ²	Ground floor and highest landing [2]
Nordrhein-Westfalen	More than 5 floors above ground and for interior, necessary stairwells	At the top point of the stairwell	With a free cross-section of at least 5% of the surface area, at least 1 m ²	Ground floor and highest landing
Rheinland-Pfalz	More than 5 floors above ground and for interior, necessary stairwells	At the top point of the stairwell	With a free cross-section of at least 5% of the surface area, at least 1 m ²	Ground floor and highest landing [2]
Saarland	In necessary stairwells of buildings with heights of more than 13 m or interior, necessary stairwells	At the top point of the stairwell	With a free cross-section of at least 1 m ²	Ground floor and highest landing
Sachsen	In necessary stairwells of buildings with heights of more than 13 m or interior, necessary stairwells	At the top point of the stairwell	With a free cross-section of at least 1 m ²	Ground floor and highest landing
Sachsen-Anhalt	In necessary stairwells of buildings with heights of more than 13 m or interior, necessary stairwells	At the top point of the stairwell	With a free cross-section of at least 1 m ²	Ground floor and highest landing
Schleswig-Holstein	In necessary stairwells of buildings with heights of more than 13 m or interior, necessary stairwells	At the top point of the stairwell	With a free cross-section of at least 1 m ²	Ground floor and highest landing
Thüringen	In necessary stairwells of buildings with heights of more than 13 m or interior, necessary stairwells	At the top point of the stairwell	With a free cross-section of at least 1 m ²	Ground floor and highest landing

[1] Exceptions can be approved if the smoke can be extracted in another way.

[2] Further control points could be demanded.

Most recent revision: 2014

Planning – selecting the drive system

Example: stairwell smoke exhaust



Step 1: Window definition – window types and opening directions (please enter number of pieces)

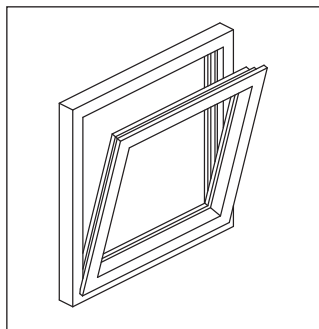

Bottom-Hung window, inward

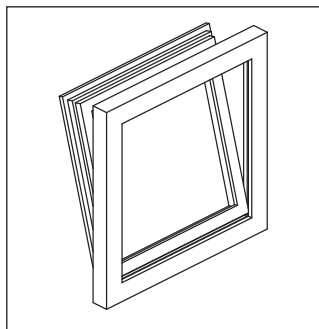

Bottom-Hung window, outward

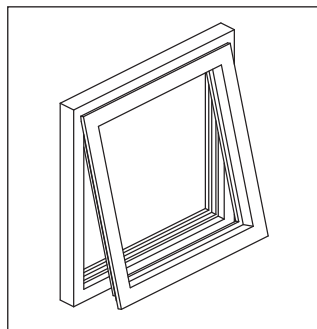

Top-Hung window, inward

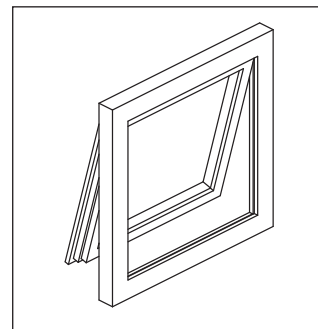

Top-Hung window, outward

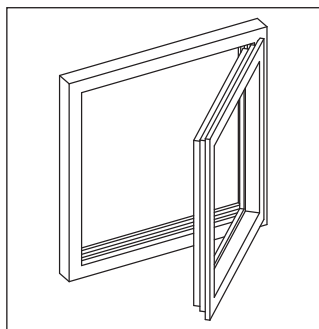

Side-Hung window, inward

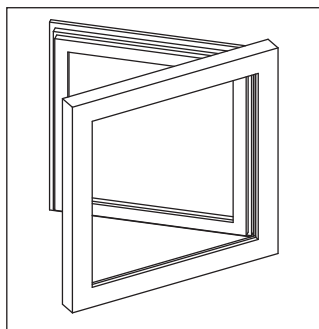

Side-Hung window, outward

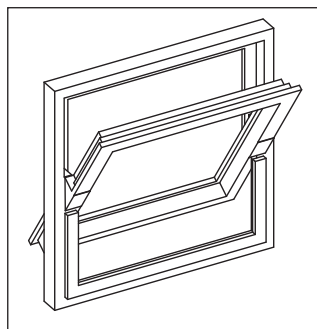

Horizontal-Pivot window

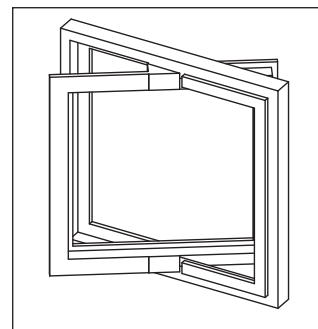

Vertical-Pivot window

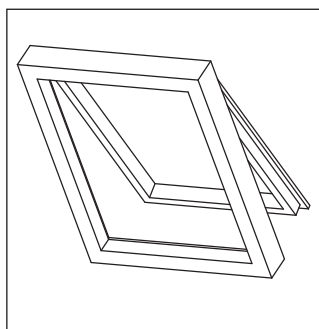

Skylight

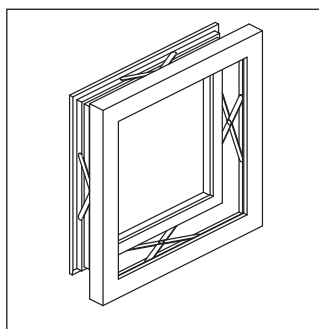

Parallel-Projecting windows

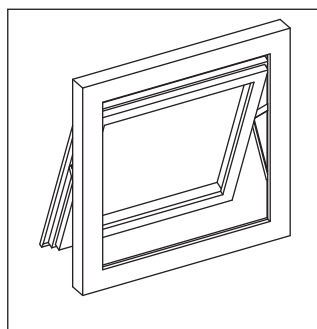

Projecting Top-Hung window

Planning – selecting the drive system

Example: stairwell smoke exhaust



Step 2: defining the application and window data

Sash exterior dimensions

Clear sash width (in mm) _____

Clear sash height (in mm) _____

Door leaf weight (in kg) _____

Alternative: glass thickness (in mm) _____

Alternative: profile weight (in kg/m) _____

Position in room [1] under 2.5 m

over 2.5 m

Stipulated geometric smoke extraction area (in m²) [2] _____

Desired opening width (in mm) _____

Alternative: desired opening angle (in °) _____

Facade/roof incline (in °) _____

Step 3: drive installation

Frame installation

Sash installation

Concealed installation

Min. space requirement (in mm) _____

Planning example: 2 Bottom-Hung windows, inward-opening

Clear sash width (in mm) 1200

Clear sash height (in mm) 850

Door leaf weight (in kg) 40

Alternative: glass thickness (in mm) -

Alternative: profile weight (in kg/m) -

Position in room [1] under 2.5 m

over 2.5 m

Stipulated geometric smoke extraction area (in m²) [2] 1

Desired opening width (in mm) 500

Alternative: desired opening angle (in °) -

Facade/roof incline (in °) Facade, 90°

Frame installation

Sash installation

Concealed installation

Min. space requirement (in mm) 60

[1] The risk analysis must be taken into consideration for an installation height of the window element below 2.50 m (see pages 459–461 – attachment 3).

[2] This value must be determined on site by the relevant fire protection authorities or the planning office based on DIN 18232-2.

Planning – selecting the drive system

Example: stairwell smoke exhaust



Step 4: determining the smoke extraction area as stipulated by DIN 18232-2

The smoke extraction area is determined with the aid of the design group, the room height and the height of the low-smoke layer from the corresponding table 3 of DIN 18232 Part 2 for each smoke compartment. This entire smoke extraction area is then split up into a corresponding number of facade openings and skylights. The corresponding regulations specified by the standard must be taken into consideration here.

Step 5: calculating the clear opening width for the predetermined geometric smoke extraction area (Ag)

You can find the calculation of the geometric smoke extraction area (Ag) on page 456 – attachment 1 „Calculation of the geometric smoke extraction area“.

Step 6: calculating the window area / opening and closing force

For calculations of the window area or the opening and closing force, see pages 457/458 – Appendix 2 "Calculating the window area / opening and closing force".

Planning example:

The stipulated geometric smoke extraction area (Ag) in accordance with DIN 18232-2 is 1 m² [1]

2 Bottom-Hung windows are designated as facade openings

This results in a required geometric smoke extraction area of 0.5 m² per facade opening

Planning example:

Calculated clear opening width = 416 mm

This means a drive with a travel length of 500 mm is required

Planning example:

Calculated opening and closing force = 535 N
(incl. wind load)

[1] This value must be determined on site by the relevant fire protection authorities or the planning office based on DIN 18232-2.

Planning – selecting the drive system

Example: stairwell smoke exhaust



Result: Selection of the drive and the associated fixing set

Determine the suitable drive and corresponding fixings based on the travel determined (step 5) and the required opening and closing force (step 6).

The selection of the drive is predominantly derived from the determined opening and closing forces (see pages 457/458 – attachment 2).

To select the corresponding fixings, check the minimum sash height in relation to travel in the corresponding tables.

Planning example:

Travel 500 mm

Sash height 850 mm

Determined required opening and closing force 535 N

Result:

Selection of drive system:



ELTRAL K30 Synchro / K-17833-00-0-*

Selection of fixing set:

Fixing set K30 / K-18157-00-0-*

Fixing set K30	
Technical data	
Opening type	Bottom-Hung window Top-Hung window Side-Hung window
Type of installation	surface-mounted
Type of installation Bottom-Hung window (drive)	Frame installation (FI)
Type of installation Top-Hung window (drive)	Frame installation (FI)
Type of installation Side-Hung window (drive)	Frame installation (FI)
Opening direction Bottom-Hung window	inward
Opening direction Top-Hung window	inward
Opening direction Side-Hung window	inward
Frame material	Aluminium Timber PVC [1]
Space requirement X min. Aluminium Timber Plastic [mm]	50 50 50

Travel [mm]	Sash height min. for FI [mm]
300	350
400	550
500	700

Finish	PU	Order number
Silver painted (RAL 9006)	1 pc	K-18157-00-0-1 
Black painted (RAL 9005)	1 pc	K-18157-00-0-6 
White painted (RAL 9010)	1 pc	K-18157-00-0-7 

Extract from order pages

SHEV air supply

Adequately sized supply air openings are always required to ensure that the smoke and heat extraction system functions safely. The supply air areas must be completely situated in the low-smoke layer and amount to at least 1.5-times the extraction area. By means of a kind of "chimney effect", these boost the thermal uplift and thus ensure that smoke gases are drawn upwards and extracted more quickly.

Air supply opening: door

We recommend the use of our door drive

- FTA600 R

Air supply opening: window

We recommend the use of our door drive

- FTA600 DF
- FTA600 GF

Planning – selecting the drive system – Appendix 1

Calculating the geometric smoke extraction area



Depending on the planning basis, a distinction is made between the aerodynamic and geometric smoke extraction area.

The German Model Building Regulation and associated regional building regulations generally require a geometric ventilation area for the removal of smoke from stairwells.

Planning example:

- Stipulated smoke extraction area $A_g = 1 \text{ m}^2$
- Number of facade openings = 2 Bottom-Hung windows
- Required smoke extraction area for each facade opening = 0.5 m^2
- Frame clearance width $FCW = 1.20 \text{ m}$
- Sash profile thickness = 75 mm

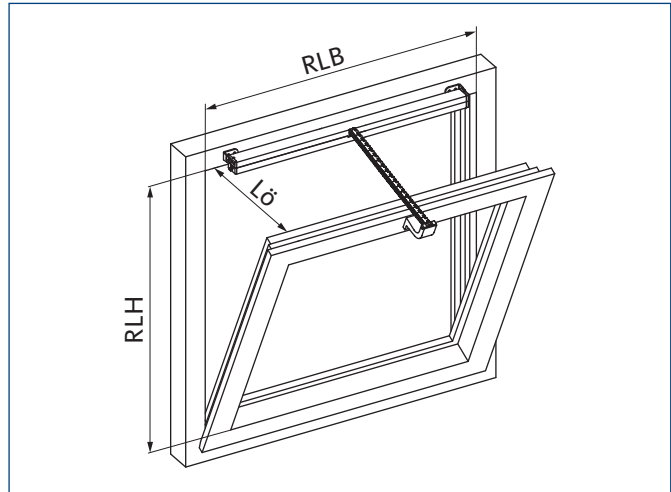

Basically, an opening angle of 60° should be aspired!

Calculation formula:

$$A_g = FCW \times O_w$$

Calculation of the clear opening width O_w for determining the drive travel length

$$O_w = A_g / FCW$$

Taking into account the sash profile thickness

$$\text{Travel} = O_w + \text{sash profile thickness}$$

Calculation formula:

$$A_g = FCW \times O_w$$

Calculation of the clear opening width O_w for determining the drive travel length

$$O_w = 0.5 \text{ m}^2 / 1.20 \text{ m} = 0.416 \text{ m}$$

$$\gg 0.416 \sim 416 \text{ mm}$$

Taking into account the sash profile thickness

$$\text{Travel} = 416 \text{ mm} + 75 \text{ mm} = 491 \text{ mm}$$

Result: a drive with a travel of 500 mm is required!

Legend:

- A_g = Geometric smoke extraction area [m^2]
- FCW = Frame clearance width [m]
- FCH = Frame clearance height [m]
- O_w = Clear opening width [m]

Be aware of the installation situation:

Further factors like the distance to the lock case cover or the arrangement of the windows must be taken into consideration for the calculation.
Need help with planning? Please contact your field consultant.

Planning – selecting the drive system – Appendix 2

Calculating the window area / opening and closing force



Step 1: calculating the window area

- Calculation of window area A: $A = FCW \times FCH$

Step 2: calculating the required opening and closing force

Calculation example: skylight

- Step 1: Calculation of the driving force depending on the sash weight P: $F_P = 5.4 \times P$
- Step 2: Calculation of the driving force depending on the sash weight P and the snow load F_{SK} [1]: $F = F_P + F_{SK}$

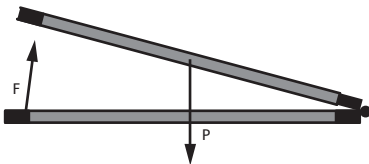

Planning example:

- Frame clearance width (FCW) = 1.20 m
- Frame clearance height (FCH) = 0.85 m

Calculation:

$$A = 1.20 \text{ m} \times 0.85 \text{ m} = 1.02 \text{ m}^2$$

Planning example: skylight

- Window area (A) = 1.2 m²
- Sash weight (P) = 60 kg
- Snow load [1] = 0.6 kN/m² = $F_{SK} = 720 \text{ N}$

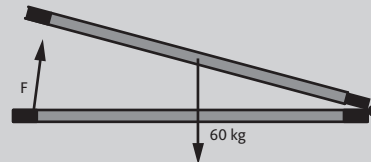

Calculating the drive force based on the sash weight P:

$$F_P = 5.4 \times 60 \text{ kg} = 324 \text{ N}$$

Calculating the drive force based on the sash weight P and the snow load F_{CF} [1]:

$$F = 324 \text{ N} + 720 \text{ N} = 1044 \text{ N}$$

Result:

On the basis of the required determined opening and closing force of 1104 N, the following drives can be used, for example:

- PLS15 Solo or PLA8 Synchro

[1] When using skylights, the snow loads must be taken into account.

Snow load information can either be determined according to DIN 1055-5 or retrieved from the respective authorities.

Planning – selecting the drive system – Appendix 2

Calculating the window area / opening and closing force



Step 2: calculating the required opening and closing force

Calculation example: facade

- Step 1: Calculation of the driving force depending on the sash weight P:

$$F_P = 5.4 \times P \times O_w / SH$$

- Step 2: calculating the drive force based on the wind load F_w [1]:

$$F_{PW} = F_w \times A / 2$$

- Step 3: calculating the drive force based on the sash weight P and the wind load F_w [1]:

$$F = F_P + F_{PW}$$

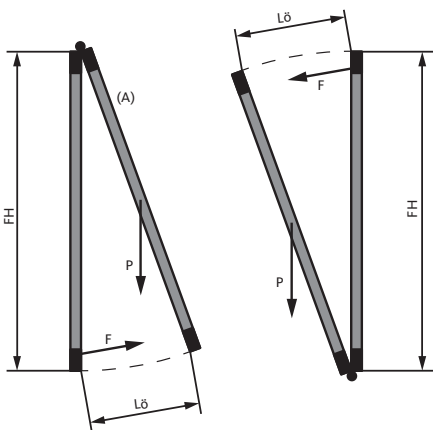

Planning example: Bottom-Hung window

- Window area (A) = 1.02 m²
- Sash width (SW) = 1.2 m or 1200 mm
- Sash height (SH) = 0.85 m or 850 mm
- Sash weight (P) = 40 kg
- Clear opening width (O_w) = 500 mm
- Wind load [1] = 800 N/m²

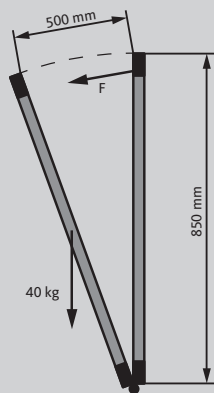

Calculating the drive force based on the sash weight P:

$$F_P = 5.4 \times 40 \text{ kg} \times 500 / 850 \text{ mm} = 127 \text{ N}$$

Calculating the drive force based on the wind load F_w [1]:

$$F_{PW} = 800 \text{ N/m}^2 + 1.02 \text{ m}^2 / 2 = 408 \text{ N}$$

Calculating the drive force based on the sash weight P and the wind load F_w :

$$F = 127 \text{ N} + 408 \text{ N} = 535 \text{ N}$$

Result:

Based on the required opening and closing force calculated at 535 N, the following drives may be used:

- KSA Solo or ELTRAL K30 Synchro

Chain drives – maximum drive forces

Max. opening and closing force	Chain drives							Spindle drives			
	KS2	KS4	KSA	KS15	KS20 [2]	K30	KS 30/40 [2]	K35	PLA8	PLA10	PLS15
F_{max} – Solo	250 N	400 N	600 N	1500 N	200 N	300 N	300 N	350 N	800 N	1000 N	1500 N
F_{max} – Synchro	500 N	800 N	1200 N	3000 N	400 N	600 N	600 N	700 N	1600 N	2000 N	3000 N

[1] The wind loads must be taken into consideration. Wind load information can either be determined according to DIN 1055-4 or retrieved from the respective authorities.

[2] Due to its plastic case, the drive is not approved for SHEV use within the EU!

Planning – selecting the drive system – Appendix 3



Risk assessment for power-operated windows in accordance with Machinery Directive 2006/42/EC



General

After the planner has carried out the evaluation of risks for force-operated windows and this has been listed in the construction requirements, the constructor of the force-operated window is obliged to repeat the evaluation of risks and to verify whether the planning specifications have been fulfilled. If the prescribed protection class has not been achieved, further steps must be taken for reduction of risks.

Extract from the Machinery Directive 2006/42/EC (MaschRL 2006/42/EC)

"The manufacturer of a machine or his authorised representative must ensure that an evaluation of risks has been undertaken in order to determine the safety and health protection requirements which are applicable for the machine. The machine must then be designed and constructed under consideration of the results of the evaluation of risks."

Expiry of evaluation of risks

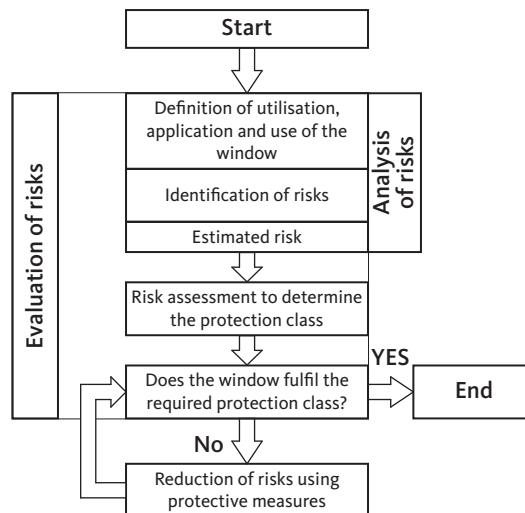

Protection classes and the resulting protection measures

Grade	Protective measures
Protection class 0	<ul style="list-style-type: none"> No protective measures required
Protection class 1	<ul style="list-style-type: none"> Warning notes
Protection class 2	<ul style="list-style-type: none"> Protection against access using structural measures or Rounded, padded edges, closing forces from 80 N to 150 N, no shearing effect or Acoustic warning signals or Warning lamps or EMERGENCY-STOP switch at the window or Moving systems in front of the window to prevent access
Protection class 3	<ul style="list-style-type: none"> Dead-man's control without overriding central control or Slow sash movement of max. 5 mm/s or Intervention width less than 8 mm or Rounded, padded edges, closing forces less than 80 N, no shearing effect
Protection class 4	<ul style="list-style-type: none"> Protection using contact-sensitive protective devices, e.g. switch rails, contact sensors, or Protection using non-contact protective devices, e.g. light barriers, light grids, or Dead man's control with authorised operation of each window without a overriding control system (e.g. spring-operated key switch) or Intervention width less than 4 mm or Prevention of access using structural measures

Planning – selecting the drive system – Appendix 3

Risk assessment for power-operated windows in accordance with Machinery Directive 2006/42/EC



Need for an evaluation of risks at the installation location due to reasonably foreseeable incorrect use

When using the power-operated window for natural ventilation, according to Machinery Directive 2006/42/EC an evaluation of risks must always be performed under the following circumstances:

- Installation height of the drive < 2.5 m above ground and
- Opening width at MCE of > 200 mm, or
- Closing speed at MCE of > 15 mm/s, or
- Opening speed at MCE of > 50 mm/s, or
- Closing force at MCE of > 150 N

The risk analysis can be performed as shown in the following flowchart, which also includes the protective measures according to EN 60335-2-103/2016-05.

Risk analysis according to DIN EN 60335-2-103

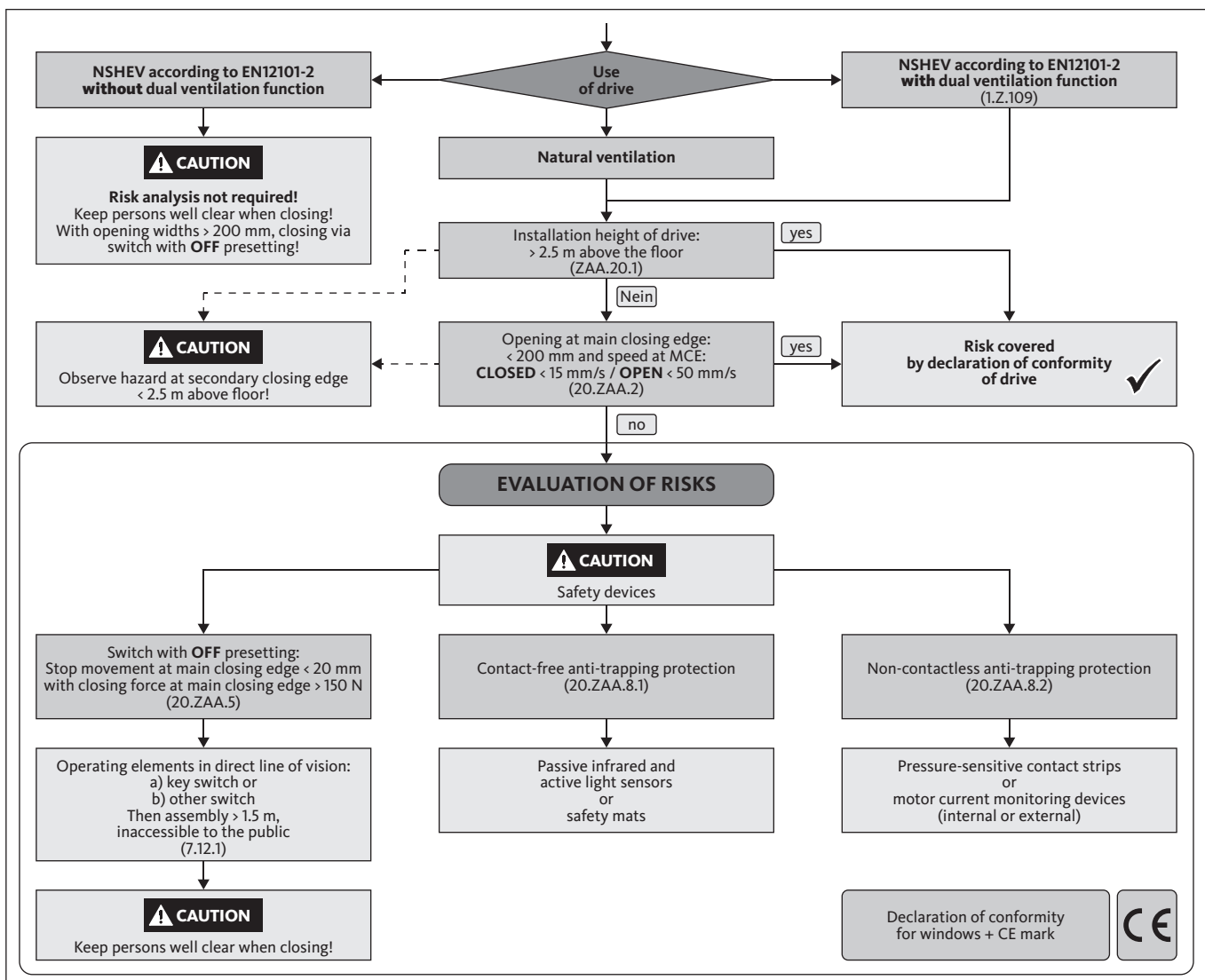

Planning – selecting the drive system – Appendix 3



Risk assessment for power-operated windows in accordance with Machinery Directive 2006/42/EC



Procedure for determining the protection classes

Procedure

Carry out the evaluation of risks in acc. with the adjacent table step by step and document the result (protection class: SK).

After the definition of the protection class, it must be determined whether the windows fulfil the required protection classes or whether a reduction of risks by the definition of protective measures is required.

Compare the result with the specifications defined by the architect/planner.

Residual risks

Once the risk assessment has been carried out and, if necessary, measures taken to minimise the risk, there is still a residual risk, e.g.:

- that unforeseeable occurrences could arise as a result of manipulation on the manual control elements or modification of the automatic operation, which have not flown into the evaluation of risks.
- that, due to force majeure, the forced controlled windows or the drives and fixings suffer damage or are destroyed and therefore represent a direct hazardous situation by falling out.

Step 1

Installation situation	Risk assessment	Risk parameters
<ul style="list-style-type: none"> ■ Installation height of the bottom edge of the sash at least 2.5 m above the finished floor or fixed access level ■ Integral devices in front of the window which impede access ■ Window sills or reveals that prevent free access to the window by the user ■ SHEV windows that are not used for ventilation 	Low risk	E1
<ul style="list-style-type: none"> ■ Installation height of the bottom edge of the sash the finished floor or access level below 2.5 m and window is freely accessible 	Higher risk	E2



Step 2

Space utilisation	Risk assessment	Risk parameters
<ul style="list-style-type: none"> ■ Rooms for commercial use, where users have been instructed on the technology (e.g. offices, industrial areas) 	Low risk	N1
<ul style="list-style-type: none"> ■ Residential spaces where residents have been familiarised with technical systems ■ Rooms where the users/visitors are able to assess the risks or are supervised 	Medium risk	N2
<ul style="list-style-type: none"> ■ Rooms, which are intended for the regular presence of people who cannot be instructed on safe use (e.g. salesrooms, places of assembly, ...) 	High risk	N3
<ul style="list-style-type: none"> ■ Rooms, which are intended for the regular presence of vulnerable people (e.g. kindergartens, schools, hospitals, ...) 	Very high risk	N4



Step 3

Control unit or operation	Risk assessment	Risk parameters
<ul style="list-style-type: none"> ■ Manual operation without self hold with visual control of all windows (deadman's control, e.g. use of a key switch with OFF pre-adjustment/key switch) 	Very low risk	S0
<ul style="list-style-type: none"> ■ Manual operation with self hold with visual control of all windows (e.g. use of a switch) 	Low risk	S1
<ul style="list-style-type: none"> ■ Automatic operation (e.g. wind/train control, building control systems) or manual operation without visual control of all windows (e.g. central control system switch, remote control) 	High risk	S2

Step 4

Determination of protection class

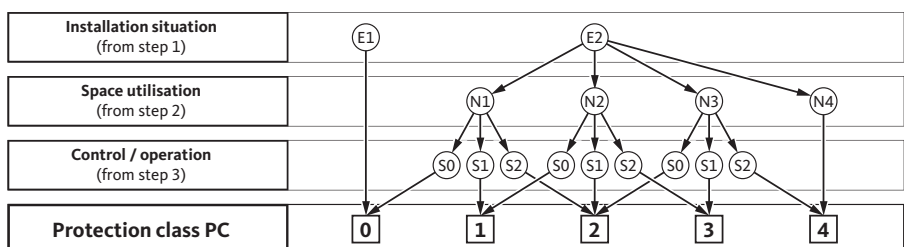

Result

Defined protection class _____ SK

Protective measures required? yes [1]

no

[1] Description of the resulting protective measures see page 459.

Selecting the right SHEV central control unit

Planning



The selection of a suitable electric control unit (SHEV central control unit) should be considered as early as the planning phase. The following points are important for this:

- The current consumption (nominal and breaking currents) of all connected drives as well as the accessory components (see following table)
- See page 451 for the minimum number of control points (SHEV push-button HSE) prescribed according to the state construction laws (in German Landesbauordnungen)
- The minimum number of automatic detectors (smoke or heat detectors) as specified by the relevant fire protection authorities
- The wiring, in particular the cable cross-sections for the drives in accordance with the Model Conduit Systems Directive (German designation: MLAR) and DIN 4102, part 12
- Division into SHEV and ventilation groups
- Optional: connection to the building control system (GLT) / fire alarm system (FAS), e.g. for overriding ventilation function
- Optional: Use of automatic ventilation controls, for example wind / rain detector, time switch
- Position/installation location for dimensioning the cable cross-sections, or for the optional connection of multiple central control units

Current consumption of drive systems

Drive/opener systems (24 V)	Designation	Nominal current	Breaking current
Chain drives	KS2	0.7 A	1.0 A
	KS4	0.9 A	1.2 A
	KSA	0.9 A	1.2 A
	KS15	3.75 A	5.0 A
	ELTRAL KS20 [1]	0.45 A	1.0 A
	ELTRAL K30	0.9 A	1.2 A
	ELTRAL KS 30/40 [1]	0.9 A	1.2 A
	ELTRAL K35	0.9 A	1.2 A
Locking drives	ELTRAL VAN	1.5 A	1.5 A
	FVUx	0.6 A	1.0 A
	OFV	0.8 A	1.1 A
Spindle drives	PLA8	1.0 A	1.4 A
	PLA10	1.9 A	2.5 A
	PLS15	3.0 A	4.0 A
Door drives	FTA600 R	1.0 A	1.4 A
Window drives	FTA600 DF	1.0 A	1.4 A
	FTA600 GF	1.0 A	1.4 A
SHEV hardware systems	1000/1050/1100 Solo SHEV with FV	0.6 A	0.8 A
	1000/1050/1100 Solo SHEV with OFV	0.8 A	1.1 A
	1000/1050/1100 Synchro SHEV	1.2 A	1.6 A
Fanlight opening systems	ELTRAL S 24	1.2 A	–

Current consumption – accessories

Accessories	Nominal current
Wind / rain detector	250 mA
Input/output module IO10	100 mA
Spring-operated key switch ST10/ST20	25 mA

[1] Due to its plastic case, the drive is not approved for SHEV use within the EU!

Selecting the right SHEV central control unit

Planning



Maximum number of drives per control unit type | Compact control units

Drive/opener systems (24 V)	Designation (Output current [2])	RZ25 (3.2 A)	RZ50 (6.5 A)	RZ75 (8.4 A)	EMB7300 (5 A)	EMB7300 (10 A)	EMB7300 (20 A)
Chain drives	KS2	3	6	8	5	10	20
	KS4	2	5	7	4	8	16
	KSA	2	5	7	4	8	16
	KS15	-	1	1	1	2	4
	ELTRAL KS20 [1]	3	6	8	5	10	20
	ELTRAL K30	2	5	7	4	8	16
	ELTRAL KS 30/40 [1]	2	5	7	4	8	16
Locking drives	ELTRAL K35	2	5	7	4	8	16
	ELTRAL VAN	2	4	5	3	6	13
	FVUx	3	6	8	5	10	20
Spindle drives	OFV	2	5	7	4	9	18
	PLA8	2	4	6	3	7	14
	PLA10	1	2	3	2	4	8
Door drives	PLS15	-	1	2	1	2	5
	FTA600 R	2	4	6	3	7	14
Window drives	FTA600 DF	2	4	6	3	7	14
	FTA600 GF	2	4	6	3	7	14
SHEV hardware systems	1000/1050/1100 Solo SHEV with FV	4	8	10	6	12	24
	1000/1050/1100 Solo SHEV with OFV	2	5	7	4	9	18
	1000/1050/1100 Synchro SHEV	2	4	5	3	6	12
Fanlight opening systems	ELTRAL S 24	2	5	7	4	8	16

Maximum number of drives per central control unit type | Modular control units

Drive/opener systems (24 V)	Designation (Output current [2])	EMB8000+ (5 A)	EMB8000+ (10 A)	EMB8000+ (24 A)	EMB8000+ (48 A)	EMB8000+ (72 A)	EMB8000+ (96 A)
Chain drives	KS2	5	10	24	48	72	96
	KS4	4	8	20	40	60	80
	KSA	4	8	20	40	60	80
	KS15	1	2	4	9	14	19
	ELTRAL KS20 [1]	5	10	24	48	72	96
	ELTRAL K30	4	8	20	40	60	80
	ELTRAL KS 30/40 [1]	4	8	20	40	60	80
Locking drives	ELTRAL K35	4	8	20	40	60	80
	ELTRAL VAN	3	6	16	32	48	64
	FVUx	5	10	24	48	72	96
Spindle drives	OFV	4	9	21	43	65	87
	PLA8	3	7	17	34	51	68
	PLA10	2	4	9	19	36	38
Door drives	PLS15	1	2	6	12	18	24
	FTA600 R	3	7	17	34	51	68
Window drives	FTA600 DF	3	7	17	34	51	68
	FTA600 GF	3	7	17	34	51	68
SHEV hardware systems	1000/1050/1100 Solo SHEV with FV	6	12	30	60	90	120
	1000/1050/1100 Solo SHEV with OFV	4	9	21	43	65	87
	1000/1050/1100 Synchro SHEV	3	6	15	30	45	60
Fanlight opening systems	ELTRAL S 24	4	8	20	40	60	80

[1] Due to its plastic case, the drive is not approved for SHEV use within the EU!

[2] The total current consumption of the connected drives and accessory components must not exceed this value.

Selecting the right SHEV central control unit

Planning example: rating of output current



Requirement:

Operation of:

- 1 pc chain drive ELTRAL K35 Synchro
- 1 pc spindle drive PLA8
- 2 pc door drive FTA600 R (2-leaf door)
- 1 SHEVs and 2 ventilation groups

Calculation:

1 pc chain drive ELTRAL K35 Synchro

- Breaking current drive K35 (2 x 1.2 A): 2.4 A

1 pc spindle drive PLA8

- Breaking current drive PLA8 1.4 A

2 pc door drive FTA600 R (2-leaf door)

- Breaking current FTA600 R drive (2 x 1.4 A) 2.8 A

Total current:

$2.4\text{ A} + 1.4\text{ A} + 2.8\text{ A} = 6.6\text{ A}$

Selected control panel: EMB7300 10 A 0102
 (with a max. output current of 10.0 A and 2 separate ventilation groups)

Selecting the right SHEV central control unit

Planning example: calculating the cable cross-section and length



Calculating the cable cross-section and length

The cross-sections of the on-site cables between the central control unit and the drives depend on the cable length, current consumption and the potential drop on the cable.

When using GU drives

$$\text{Cable cross-section [mm}^2\text{]} = \frac{\text{Single cable length [m]} \times \text{number of drives}}{\text{Factor } f_{\text{drive}}}$$

$$\text{Single cable length [m]} = \frac{\text{Cable cross-section [mm}^2\text{]} \times \text{factor } f_{\text{drive}}}{\text{Number of drives}}$$

Factor f_{drive}

Drive	KS15	PLS15	PLA10	SHEV 1000 SHEV 1050 SHEV 1100 Synchro	VAN	PLA8 FTA600	KS4 KSA K30 KS 30/40 K35 S 24	OFV M-COM SHEV 1000 SHEV 1050 SHEV 1100 Solo with OFV	KS2 KS20	FVUx SHEV 1000 SHEV 1050 SHEV 1100 Solo with FV
Factor f_{drive}	11	14	22	35	37	40	46	51	56	70

Calculation example: Requirement: Operation of 5 ELTRAL K35 chain drives in a stairwell with a simple cable length of 25 m between the SHEV compact control unit and drives

Calculation: Cable cross-section [mm²] = $\frac{25 \text{ m} \times 5}{46} = 2.72$

Selected cable cross-section: 3.0 mm²

When using drives from other manufacturers

The cable cross-section is calculated using the cable length and the sum of the breaking currents of the drives to be connected.

$$\text{Min. cable cross-section [mm]} = \frac{\text{Single cable length [m]} \times \text{sum of breaking currents [A]}}{56}$$

Maximum cable length (central control unit – drive)

End of line cross-section	Sum of breaking currents										
	1.0 A	2.0 A	3.0 A	3.2 A	4.0 A	5.0 A	6.0 A	6.5 A	7.0 A	8.0 A	8.4 A
3 x 1.0 mm ²	56 m	28 m	18 m	17 m	14 m	11 m	9 m	8 m	8 m	7 m	6 m
3 x 1.5 mm ²	84 m	42 m	28 m	26 m	21 m	16 m	14 m	12 m	12 m	10 m	10 m
3 x 2.5 mm ²	140 m	70 m	46 m	43 m	35 m	28 m	23 m	21 m	20 m	17 m	16 m
3 x 3.0 mm ²	168 m	84 m	56 m	52 m	42 m	33 m	27 m	25 m	24 m	21 m	20 m
5 x 2.5 mm ² *	280 m	140 m	93 m	87 m	70 m	56 m	45 m	43 m	40 m	35 m	33 m

* Doubling the current conducting wires (results in a cable cross-section of 5.0 mm² each).

Protection classes (IP) according to DIN 60529



Protection classes (IP) according to DIN 60529

1st code number	Protection against solid foreign bodies	2nd code number	Protection against water
0	No contact protection, no protection against solid foreign objects	0	No protection against water
1	Protection against large-format contacts with the hand, protection against foreign objects with $\varnothing > 50$ mm	1	Protection against vertical water drips
2	Protection against finger contact, protection against foreign objects with $\varnothing > 12$ mm	2	Protection against obliquely falling water drips from any angle of to 15° from the vertical
3	Protection against tool contact, e.g. wires with $\varnothing > 2.5$ mm, protection against foreign objects with $\varnothing > 2.5$ mm	3	Protection against obliquely falling water drips from any angle of to 60° from the vertical
4	Protection against tool contact, e.g. wires with $\varnothing > 1.0$ mm, protection against foreign objects with $\varnothing > 1.0$ mm	4	Protection against splashing water from all directions
5	Protection against contact, protection against dust deposits inside	5	Protection against water jet (nozzle) from any angle
6	Complete protection against contact, protection against ingress of dust	6	Protection against strong water jets (nozzle) from any angle
		7	Protection against water penetration with temporary immersion (30 minutes)
		8	Protection against water penetration with permanent immersion, requested following consultation between manufacturer and user
		9 K	Protection against high-pressure water penetration (8,000 – 10,000 kPa) from a nozzle or steam jet cleaning from any direction

Duty ratio (ED) according to DIN VDE 0530-1

Wind strengths according to Beaufort



Duty ratio (ED) according to DIN VDE 0530-1

The duty ratio refers to the maximum permissible operating time of the drives, after which time there must be a rest period in order to avoid damaging or destroying the drives.

The duty ratio is specified in DIN VDE 0530-1.

For a period of use of 10 minutes and a duty ratio of 20 %, the operating time is 2 minutes and the rest period is 8 minutes.

Code number	Operating mode
S1	Continuous operation, constant load
S2	Brief operation, constant load
S3	Intermittent operation without the influence of the start process on the temperature
S4	Intermittent operation with the influence of the start process on the temperature
S5	Intermittent operation with the influence of the start process and stopping on the temperature
S6	Continuous operation with intermittent load
S7	Continuous operation with starting process and stopping
S8	Continuous operation with alternating load

Wind strengths according to Beaufort – resulting wind loads

Wind strength	Designation	m/s Top boundary	km/h Top boundary	Wind pressure [kN/m ²]
1	Light draught	1.5	5.4	0.0016
2	Slight breeze	3.3	11.88	0.0077
3	Gentle breeze	5.4	19.44	0.0207
4	Moderate breeze	7.9	28.44	0.0444
5	Fresh breeze	10.7	38.52	0.0814
6	Strong breeze	13.8	49.68	0.1354
7	Brisk wind	17.1	61.56	0.2079
8	Stormy wind	20.7	74.52	0.3047
9	Storm	24.4	87.84	0.4234
10	Severe storm	28.4	102.24	0.5736
11	Violent storm	32.6	117.36	0.7558
12	Gale	35	126	0.8712
13	50-year storm	41	147.6	1.1954

Essential information for installers and operators



General service notes

Builders and operators of SHEV systems are legally obliged to take all necessary precautions in order to protect persons and material goods within the building. For this reason, special attention must be paid to commissioning, the function test and regular maintenance and repair.

Annual maintenance must be carried out by the manufacturer or experts (qualified personnel authorised by the manufacturer) in order to preserve the functionality. Systems must be treated according to the information of the manufacturer in terms of product information and intended use, misuse, product performances and information and instruction obligations.

Applicable regulations

- **Model building regulation (MBO §3) and state building regulation (LBOs)**
Structural installations as well as other systems ..() must be arranged, erected, modified and serviced in such a way that public safety and order, in particular life, health or natural livelihoods are not endangered.
- **DIN 18232, part 2**
In accordance with the manufacturer's specifications (as a rule once a year), SHEV systems and their operation and control elements, opening devices, power supply lines and accessories must be tested for functionality and operating state, maintained and repaired if necessary. Maintenance work may only be carried out by specialist firms qualified to do so on SHEV systems.
- **EN 12101-2: Heat and smoke control systems**
Definitions of natural smoke and heat exhaust ventilators (NSHEVs) as integral part of a SHEV system
- **EN 12101-9 and DIN EN 12101-10:**
Heat and smoke control systems
Control panels and power supply
- **VdS Guidelines 2098 and 2257**
- **EN 54: Automatic smoke and heat detector**
- **DIN 31051:2003-06: Servicing, inspection and maintenance of SHEV systems**
- **DIN 60335-2-103: Drives for gates, doors and windows**
- **DIN VDE 01000-10: Requirements and definitions of qualified electricians**
- **VFF information sheet WP01, WP02, WP03**
- **ASR 1.6/1.7: Directives for force-controlled windows**
- **Manufacturer's installation and operating instructions**

Furthermore, the regulations imposed by the responsible building supervision authorities, the trade supervisory authority, the fire brigade, the regional building regulations (LBO), the technical inspection ordinances of the German Federal States or special ordinances must be complied with.

The operator must perform at least one visual inspection in between these annual maintenance intervals, which must be documented in the test log book.



Important!

- Failure to carry out regular maintenance may result in legal ramifications for the builder or operator
- There is a danger of injury during maintenance due to manual or automatic control of the opening element.
- If the premises are excessively exposed to dirt and dust, the maintenance intervals must be reduced accordingly.
- When exchanging consumable or replacement parts, it must be ensured that the interplay between the system components is correct and trouble-free (system compatibility). Only consumables or spare parts with the corresponding approval (listed in the general test certificate ABP in accordance with DIN 18232) or original parts may be used.
- In accordance with the liability of the manufacturer for his products defined in the "German Product Liability Law" (§4 Prod-HaftG), the following information concerning smoke and heat exhaust ventilation systems must be observed. Non-observation shall release the manufacturer from his liability.

Intended use

Smoke and heat exhaust ventilation systems are a fixed integral part of fire prevention with the task of discharging combustion gases, dangerous oxides and thermal energy outdoors in event of fire.

They consist of elements such as mechanisms for opening and closing windows, light domes and smoke flaps with the aim of

- keeping escape and rescue routes smoke-free in the event of a fire
- facilitating the fire fighting process

The non-use or disregard of the entries in the test log book constitutes misuse of the SHEV system and may result in a risk to persons and considerable material damage to the building and its installations.

Essential information for installers and operators



Information for the operator

The SHEV system must be kept in a constant operational state by the operator, and must be checked at least once a year to ensure that the interplay between all components is correct and trouble-free. Furthermore, maintenance must be carried out either by the operator or qualified personnel. As well as testing the detectors/ alarm devices, push-buttons and central control units, this test and maintenance must also include the maintenance of all drives, fixings and hardware of the opening system.

These tests and maintenance procedures may only be carried out by an expert authorised by the manufacturer. The scope, results and time of the tests and maintenance must be recorded. These records must be kept by the operator.

The following documents must be kept in a safe place by the operator

- Acceptance certificates / log book
- Assembly instructions / operating instructions
- "Function tests" checklists

The following points must be observed by the operator:

- Regular visual inspection to check that components are functioning correctly
- System must be kept in a constant operational state
- Annual check
- Annual maintenance
- Documentation obligation
- Retention obligation for documents



Building Rules List

The regional building regulations stipulate that the technical regulations, as introduced by the supreme building supervision authorities of the respective Federal State by way of public notification, must be observed. The Deutsche Institut für Bautechnik (German Institute for Building Technology – DIBt) is tasked with establishing the technical regulations for building products and designs in Building Rules Lists A, B and C, and publishing these in agreement with the supreme building supervision authorities of the respective Federal States.

The Building Rules List B, part 1, is reserved for building products that are put into circulation based on the German Building Products Act, and for which there are technical specifications, classes and performance levels depending on the intended use.

List of abbreviations



List of abbreviations SHEV and ventilation systems

A	Window area
A _g	Geometric smoke extraction area
AP	On-wall version
BCL	Bracket clamping area
ESH	Exterior sash height
ESW	Exterior sash width
F	Driving force
FAS	Fire alarm system
FCH	Frame clearance height
FCW	Frame clearance width
FI	Frame installation
L	Length
LBO	State construction law (in German Landesbauordnung)
LM	Chain clearance
LP	Locking point
MBO	Model building regulation
MCE	Main closing edge
MRA	Mechanical smoke exhaust system
NRA	Natural smoke exhaust system
OL	Overlap width
O _w	Clear opening width
P	Sash weight
PU	Packing unit
RDA	Smoke protection pressure system
SCE	Secondary closing edge
SH	Sash height
SHEV	Smoke and heat exhaust ventilation system
SI	Sash installation
SK	Protection class
SW	Sash width
UP	In-wall version

List of abbreviations fanlight opening systems

B	Total width
B-E	Window sill to lower end of hand lever
FBs	Sash width on pitched side
FCH	Frame clearance height
FCW	Frame clearance width
FHf	Sash height bottom edge of sash to middle of pitched side
L	Rod length
M	Sash centre
O-B	Top edge of sash to window sill
O-E O-end	Top edge of sash to end of hand lever
OL	Overlap height or window sill projection
PU	Packing unit
SH	Sash height
SW	Sash width
T	Recess depth
U-end	Bottom edge of sash to end of hand lever







Indication character of the technical information, exclusion of liability

The technical documents are general information based on our experience and tests and therefore do not take any specific application into account. They are intended as general information and for initial orientation only, and must not be used as the decision-making basis. They reflect the version of the catalogue at the time of going to press. Although we have made every attempt to ensure the information provided here is accurate, it is non-binding. It should be adapted to the respective construction projects, usage and specific on-site demands. As a consequence of further developments, but also in order to take current developments into account and to exclude printing errors or other mistakes, you will find the current version of the binding technical documents at www.g-u.com. Be sure to use the latest edition of our technical documents.

The product images shown in the publication may differ from the actual product, particularly as a result of technical improvements. We would also like to draw your attention to the current information at the website mentioned above.

Copyright notice

© All illustrations and texts in this publication are protected by copyright. Unless otherwise stated in the image, the rights belong to the Gretsch-Unitas group. Any use of copyright protected materials without the consent of the holder of the rights is prohibited.

Image credits

Page 450 Paragraph with EU flag provided by Collection E+ / Getty Images

Publisher
Gretsch-Unitas GmbH
Baubeschläge
Johann-Maus-Str. 3
71254 Ditzingen
Germany
Tel. +49 7156 3 01-0
Fax +49 (0)7156 3 01-293
www.g-u.com



WINDOW TECHNOLOGY
DOOR TECHNOLOGY
AUTOMATIC ENTRANCE SYSTEMS
BUILDING MANAGEMENT SYSTEMS

Gretsch-Unitas GmbH
Baubeschlage
Johann-Maus-Str. 3
71254 Ditzingen
Germany
Tel. +49 7156 301-0
Fax +49 7156 301-77980

BKS GmbH
Heidestr. 71
42549 Velbert
Germany
Tel. +49 2051 201-0
Fax +49 2051 201-9733

www.g-u.com

WP00009-04-1-1 08/2023

Securing technology for you

