



WINDOW TECHNOLOGY
DOOR TECHNOLOGY
AUTOMATIC ENTRANCE SYSTEMS
BUILDING MANAGEMENT SYSTEMS



LATEST PRODUCT INFORMATION FOR FABRICATORS

1

Pre-assembled GU-thermostep threshold for Lift&Slide elements

Securing technology for you





Pre-assembled GU-thermostep threshold for Lift&Slide elements

With the GU-thermostep 164 and 204, a service is available that gives you the opportunity to order a threshold that has been completely cropped to the required dimension, pre-drilled and pre-assembled. This reduces manufacturing time and manufacturing expenditure which in turn reduces costs for you as fabricator. This service is provided at different pre-fabrication stages which you can select.

- No stock keeping of individual parts, so reduced inventory size and warehouse costs
- No offcuts and leftover amounts
- Reduced manufacturing time and costs
- Reduction of errors when cropping to size
- Reduction of errors when calculating and ordering the threshold

Premium: high degree of prefabrication

The scope of delivery includes the threshold and all necessary accessory parts, cut to the required length, mounted and fixed with screws. The corner connectors are mounted and all required sealing work is done.

Exclusive: highest degree of prefabrication

The following hardware articles can be ordered made to measure:

- Drip rail extensions (25, 40, 60 mm)
- Vertical profile extensions
- Lift&Slide gears D27,5 and D37,5
- The bogies are pre-assembled together with the connecting rod which has been cropped to the required length
- Guide track P 1786 and P 1850 made to measure incl. accessories for timber profile systems
- Structural connection set
- HS CleanUnit
- Comfort package with HS LiftUnit and handle damper as Light version for sash weights up to 200 kg and Heavy version for sash weights up to 400 kg
- Optionally available with DIRIGENT turn handle and security package for burglar inhibition according to RC 2

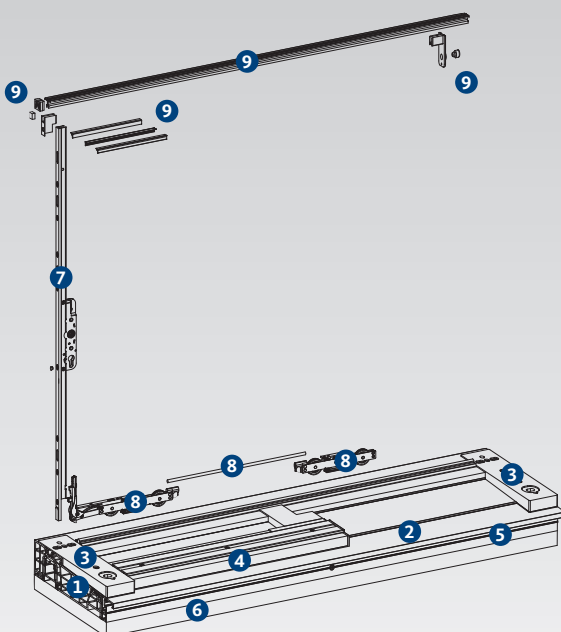

Pre-assembly grade		
	Premium	Exclusive
1 Threshold	■	■
2 Drip rail	■	■
3 Corner connectors	■ mounted	■
4 Attachment track	■ mounted	■
5 Extension of drip rail		■
6 Profile extension		■
7 Lift&Slide gear		■
8 Bogies with connecting rod		■ pre-assembled
9 P 1786 and P 1850 guide track incl. accessories		■

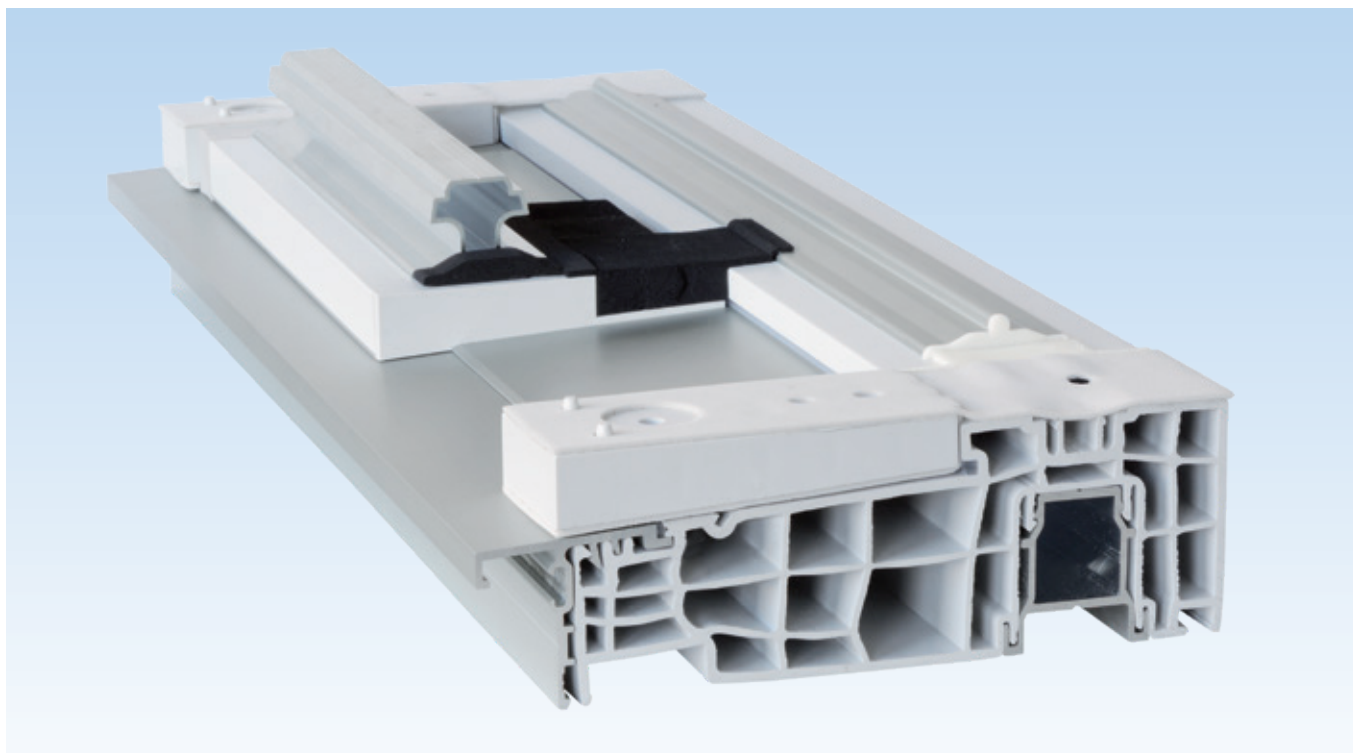

Threshold pre-assembled to the highest degree of fabrication (above: the GU-thermostep 204 for Veka Slide 82)

The following Lift&Slide systems are available:

Lift&Slide system PVC		
Profile systems	Pattern A	Pattern C
Veka Slide 82	■	■
Profine PremiDoor 88	■	■
Aluplast HST 85	■	■
Rehau Geneo	■	■
Rehau Synego	■	■
Gealan S 8000	■	■
Gealan S 9000	■	■
Schüco ThermoSlide SI 82	■	■
Aluplast Ideal 4000	■	■
Salamander eD	■	■
Schüco Corona CT 70	■	■

Lift&Slide system timber		
Sash thickness [mm]	Pattern A	Pattern C
56	■	■
68	■	■
78	■	■
88	■	■
90	■	■
92	■	■
110	■	■



WINDOW TECHNOLOGY
DOOR TECHNOLOGY
AUTOMATIC ENTRANCE SYSTEMS
BUILDING MANAGEMENT SYSTEMS

Gretsch-Unitas GmbH
Baubeschlage
Johann-Maus-Str. 3
71254 Ditzingen
Germany
Tel. +49 7156 301-0
Fax +49 7156 301-77980

BKS GmbH
Heidestr. 71
42549 Velbert
Germany
Tel. +49 2051 201-0
Fax +49 2051 201-9733

GU Automatic GmbH
Karl-Schiller-Str. 12
33397 Rietberg
Germany
Tel. +49 5244 9075-100
Fax +49 5244 9075-599

www.g-u.com

Securing technology for you

