



WINDOW TECHNOLOGY
DOOR TECHNOLOGY
AUTOMATIC ENTRANCE SYSTEMS
BUILDING MANAGEMENT SYSTEMS



AUTOMATIC ENTRANCE SYSTEMS



Portfolio: sliding doors, swing door drives, revolving doors, all-glass sliding walls



Securing technology for you
Vorsprung mit System





Systematic Service

Automatic sliding doors.....	4 – 23
Automatic swing-door drives.....	24 – 27
Automatic revolving doors.....	28 – 35
Controlled physical access systems.....	36 – 39
Manual and automatic all-glass sliding walls.....	40 – 45
GU service.....	46 – 48
Copyright notice/Image credits.....	49

Those who wish to turn architectural visions into reality require the right technical solutions. Architects and planners therefore depend on the Gretsch-Unitas group of companies: as one of the international market leaders for window and door technology as well as automatic entrance and building management systems we are the competent partner for forward-thinking architecture and state-of-the-art technical systems – whether straightforward or complex. Our expertise is founded in the 100-year old tradition of our family-owned company, which has always stood for innovation, progress and cost-effectiveness. In keeping with our guiding principle "Securing technology for you", we support our customers from planning through to implementation of automatic entry door system solutions, whether new build, refurbishment or retrofitting projects. The most appropriate system can be selected as required from a multitude of technical and creative possibilities. GU Automatic GmbH is your committed, competent and reliable partner in this regard.

More than an entrance - an experience.

Automatic sliding doors are easy and convenient to pass through, meaning they are scarcely noticed by those using the building. They provide a modern entrance solution for public buildings, airports, train stations, shopping centres, banks, hospitals, retirement homes and homes for the disabled. With their compact and slimline design and their drive height of just 100 mm, the sliding doors from the compactMaster series do not just provide reliable functionality, but are also extremely attractive and elegant. Conflicting directives are reconciled with the HM-F FT escape route sliding door. The type-tested escape route sliding door guarantees a secure escape route, even when locked.





compactMaster CM and CM-F in-line sliding door

The slim sliding door with elegant appearance



Slim and technically perfect



With its compact design and attractive, elegant appearance, the compactMaster in-line sliding door harmonises especially well with architecturally sophisticated glass facades and emphasises their munificence and transparency.

The "true" drive height is only 100 mm, meaning the door leaf's upper profile in the slim profile system is integrated into the drive and concealed by the cover.

Large rollers and a rubber mat under the roller track ensure outstanding running smoothness.

The drives are certified to DIN 18650/EN 16005, type-tested by TÜV and comply with the current directives and standards. The redundant CM-F drive system is tested and suitable for use in escape and rescue routes (AutSchR – German directive governing automatic sliding doors in rescue routes).

In the CM WK2 and CM-F WK2 versions, the drives are tested in accordance with EN 1627 to ensure they are burglar-inhibiting.

Convincing in detail:

- Type *CM-F*: redundant drive with 2 motors for use in escape and rescue routes
- Type *CM WK2/CM-F WK2*: sliding door tested in accordance with EN 1627, in conjunction with automatic AMV multi-point locking, additional components that prevent forced entry as well as the use of P4A safety glass or a suitable filling
- "True" drive height of 100 mm in conjunction with the G30 profile system
- Running smoothness thanks to large rollers with exchangeable rubber-coated running face
- Clear and simple operation
- Optionally available with locking element integrated into the carriage, AMV automatic multi-point locking or floor/hook bolt lock
- Self-learning control system with many connection and adjustment options

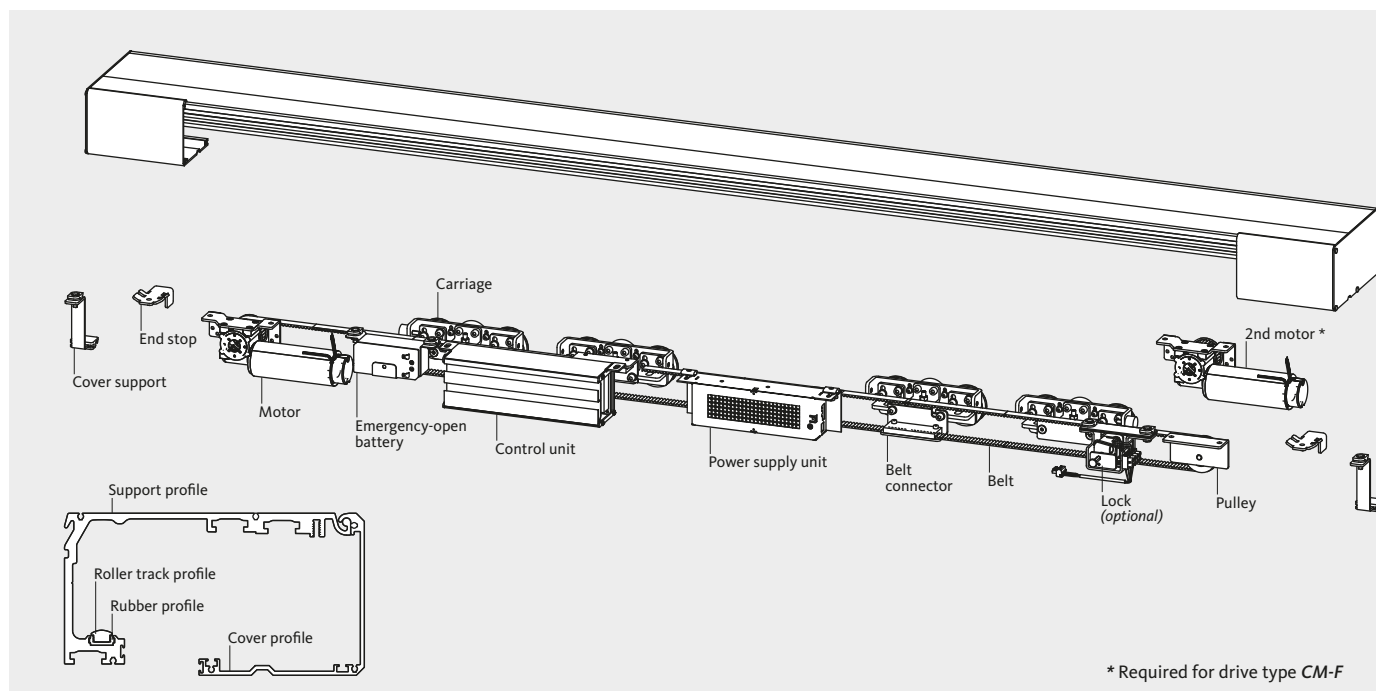

Designation	compactMaster CM/compactMaster CM-F	
	1-leaf	2-leaf
Use		
Clear passage width ^{[1][2]}	800–2000 mm	800–3000 mm
Clearance height ^[1]	max. 3000 mm	
Drive height	100 mm	
Door leaf weight	max. 100 kg/leaf	
Supply voltage	230 V AC, 50 Hz	
Power consumption	max. 160 VA (50 VA during operation)	
Hold-open time	0–99 s	
Hold-open time with key impulse	0–99 s	
Opening speed	max. 0.9 m/s	
Closing speed	max. 0.5 m/s	
Winter opening width ^[2]	50%–100% of the clear passage width	
Protection type/Ambient temperature	IP20 (for dry rooms only)/–15 °C up to +50 °C	

[1] Standard dimensions, taking into account the overall measurement, the ratio of height and width and the local installation conditions; special solutions on request.

[2] The mandatory escape route width must be observed.

econoMaster EM und EM-F in-line sliding door

Reliable and economical – for almost all applications



Reliable and easy to install



The tried and tested technology of the econoMaster drive system with 2 rollers and one counter roller per carriage guarantees low wear and high cycle numbers.

With permissible door leaf weights of up to 130 kg, large passage widths can be achieved with our slim G30 profile system or with thermally separated profile systems with an outstanding price-performance ratio.

Whether your door assembly consists of drive and sliding panels only or also includes sidelights or fanlights, GU Automatic offers you full service, consisting of installation, commissioning, and maintenance.

The drives are certified to DIN 18650/EN 16005, type-tested by TÜV and comply with the current directives and standards. The EM-F drive system is tested and suitable for use in escape and rescue routes (AutSchR).

© EYE-SCREAM, Hansjörg Riedel

Convincing in detail:

- **Type EM-F:** redundant drive with 2 motors for use in escape and rescue routes
- Matured and proven mechanics
- Fast opening speed of up to max. 0.9 m/s
- Clear and simple operation
- Optionally available with locking element integrated into the carriage or floor/hook bolt lock (optional)
- Easy installation of roller track and drive components
- Self-learning control system with many connection and adjustment options
- Continuous floor guide (optional)

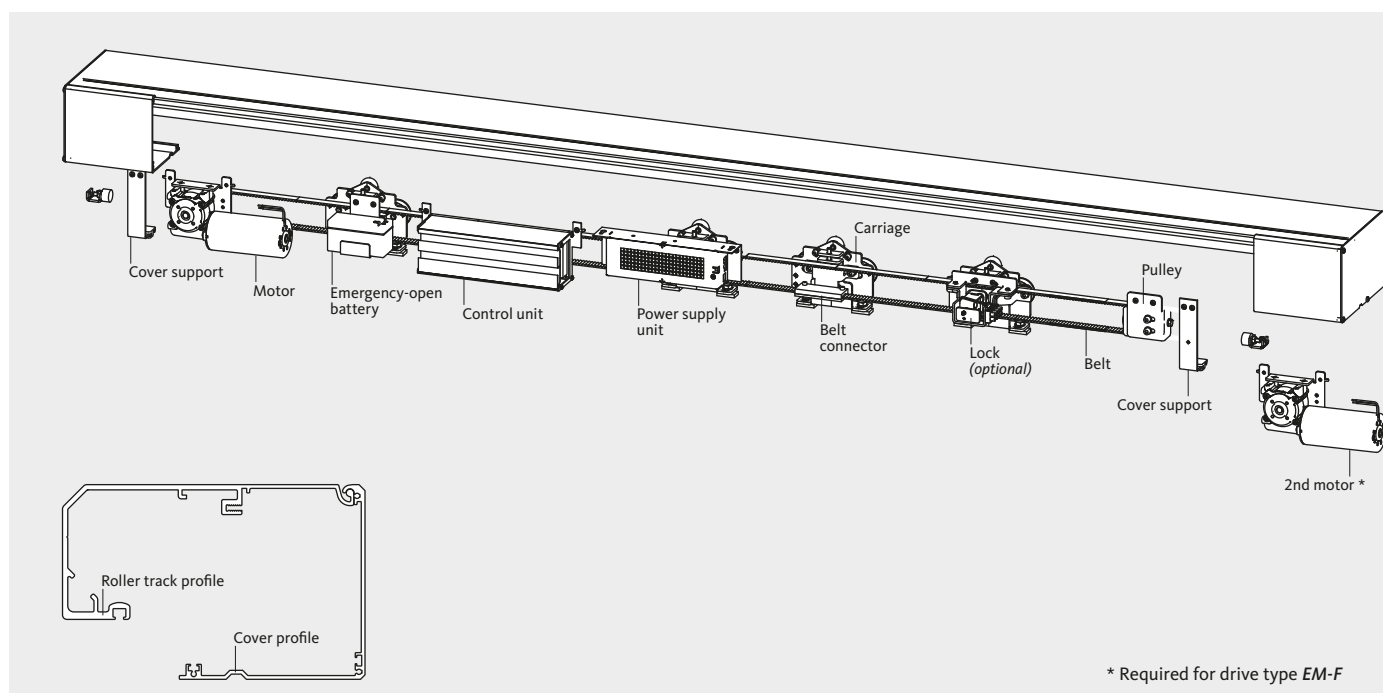

Designation	econoMaster EM/econoMaster EM-F	
	1-leaf	2-leaf
Use	800–2000 mm	800–3000 mm
Clear passage width ^{[1][2]}	max. 3000 mm	
Clearance height ^[1]	130 mm	
Drive height	max. 130 kg/leaf	
Door leaf weight	230 V AC, 50 Hz	
Supply voltage	max. 160 VA (50 VA during operation)	
Power consumption	0–99 s	
Hold-open time	0–99 s	
Hold-open time with key impulse	max. 0.9 m/s	
Opening speed	max. 0.5 m/s	
Closing speed	50%–100% of the clear passage width	
Winter opening width ^[2]	IP20 (for dry rooms only)/–15 °C up to +50 °C	
Protection type/Ambient temperature		

[1] Standard dimensions, taking into account the overall measurement, the ratio of height and width and the local installation conditions; special solutions on request.
 [2] The mandatory escape route width must be observed.

heavyMaster HM and HM-F in-line sliding door

The problem-solver for special requirements



Robust and powerful



The heavyMaster sliding-door drive is the problem-solver for your special requirements. Sliding panels with large dimensions or heavy weights of up to 200 kg are driven reliably and silently.

Even in very high-traffic entrance areas, the heavyMaster ensures optimal running characteristics with the least wear, thanks to the stable carriage and large rollers with rubber-coated running face. Sliding panels framed with thermally broken profile systems or steel profiles are ideally suited for assembly with heavyMaster.

The drives are certified to DIN 18650/ EN 16005, type-tested by TÜV and comply with the current directives and standards. The HM-F drive system is tested and suitable for use in escape and rescue routes (AutSchR).

Convincing in detail:

- **Type HM-F:** redundant drive with 2 motors for use in escape and rescue routes
- Stable carriage with large rollers
- Running smoothness thanks to rollers with an exchangeable rubber-coated running face
- Clear and simple operation
- Optionally available with locking element in the carriage or floor/hook bolt lock (optional)
- Delicate-appearing G30 profile system for sliding panels with up to 120 kg door leaf weight
- Self-learning control system with many connection and adjustment options
- Continuous floor guide (optional)

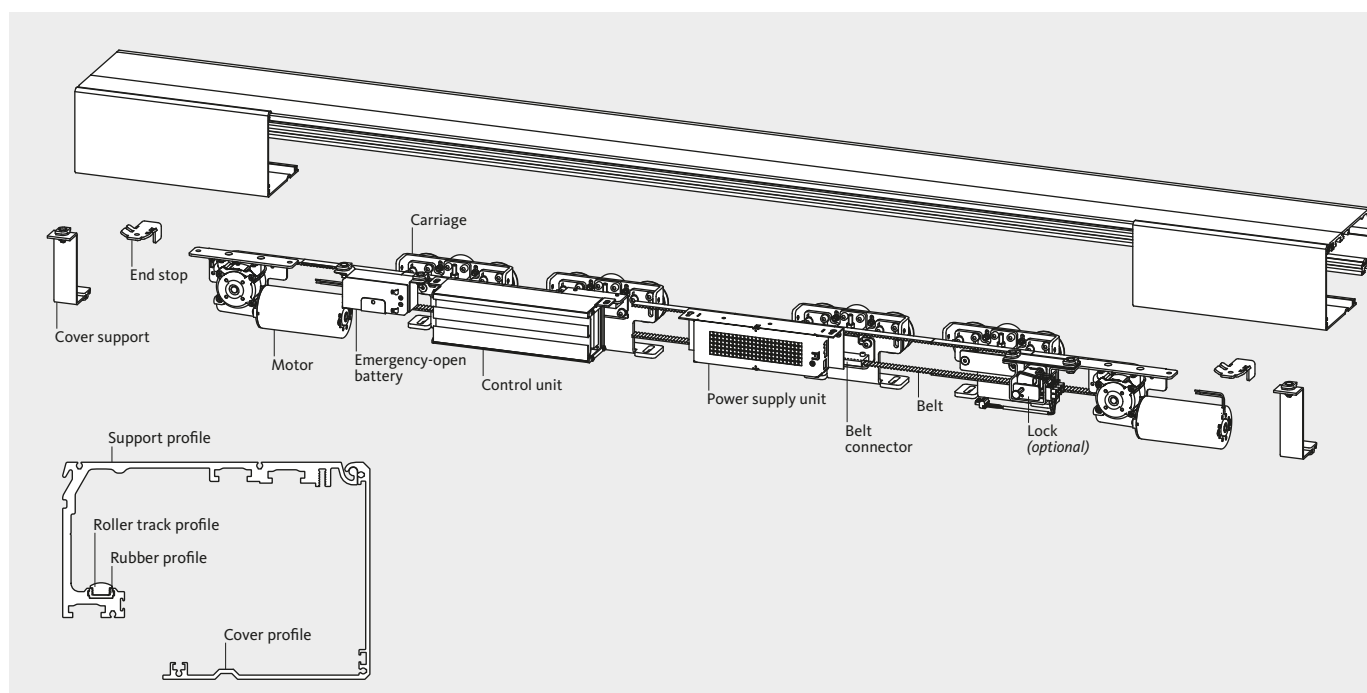

Designation	heavyMaster HM/heavyMaster HM-F	
	1-leaf	2-leaf
Use		
Clear passage width ^{[1][2]}	800–2000 mm	1000–3000 mm
Clearance height ^[1]	max. 3000 mm	
Drive height	130 mm	
Door leaf weight	max. 200 kg/leaf	
Supply voltage	230 V AC, 50 Hz	
Power consumption	max. 160 VA (50 VA during operation)	
Hold-open time	0–99 s	
Hold-open time with key impulse	0–99 s	
Opening speed	max. 0.9 m/s	
Closing speed	max. 0.5 m/s	
Winter opening width ^[2]	50%–100% of the clear passage width	
Protection type/Ambient temperature	IP20 (for dry rooms only)/–15 °C up to +50 °C	

^[1] Standard dimensions, taking into account the overall measurement, the ratio of height and width and the local installation conditions; special solutions on request.
^[2] The mandatory escape route width must be observed.

HM-F FT escape route sliding door

Guaranteed escape route even when door is locked



Fulfils both directives and architectural visions



Buildings such as hospitals, hotels and airports as well as residential care homes for the elderly and disabled must always provide an escape option in night mode. During the day the benefits of an automatic sliding door, such as rapid opening, should also be available. Fortunately the first sliding door also to be approved as an escape door when locked is now available from the GU group: the escape route sliding door HM-F FT guarantees the availability of rescue routes and that the building is closed – all in one door element with no other escape door required. This gives architects and planners more freedom when designing prestigious entrances that must comply with the AutSchR (German directive governing automatic sliding doors in rescue routes), EltVTR (German directive governing electrical locking systems on doors in escape routes), and also DIN 18650 and EN 16005.



Automatic/Exit operating mode

The movement sensors are active in Automatic or Exit operating mode. The door opens automatically when approached. Redundancy ensures that the sliding door opens automatically in the escape direction.



Off/Night operating mode

The sliding door becomes a swing door with escape door security. The door is locked and the movement sensors are inactive – the door therefore no longer opens when approached. The sliding door is secured against being pushed open via the integrated sliding door locking system and against break-out by escape door strikes in the pivot hardware.

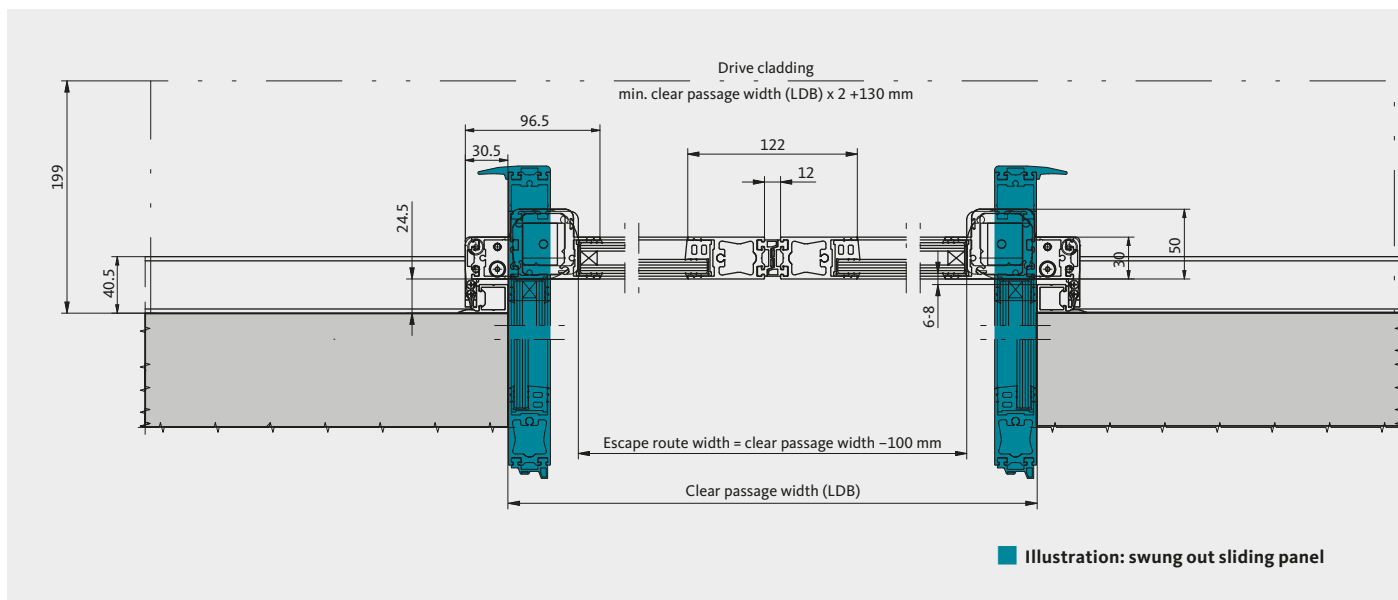

Type of drive	HM-FFT	
	1-leaf	2-leaf
Use		
Clear opening width	900–1300 mm	1200–2600 mm
Clear escape route width ^[1]	850–1250 mm	1100–2500 mm
Clearance height	max. 3000 mm	
Clear escape route height	max. 2947 mm	
Drive height	130 mm	
Minimum drive length	2x CPW + 70 mm	2x CPW + 130 mm
Opening speed	max. 0.9 m/s	

^[1] The mandatory escape route width must be observed.



Off/Night operating mode – emergency

If the emergency push-button is pressed or if triggered via the building control system, the electric escape door strikes are released. The swing leaves can also be pushed open in the event of a power failure or in a panic situation. The escape route is ensured, even if a load is applied on the door leaves in the escape direction.



Off/Night operating mode – authorised access

The door can be unlocked by authorised persons via access control or push-buttons on the inside and accessed as a sliding door. Following access, the door locks automatically.

econoMaster EMT and EMT-F telescopic sliding door

For maximum passage widths in minimum space



Fast opening, large entrances

Telescopic sliding doors are ideally suited to achieving a broad passageway and optimal people flow in narrow spaces.

The continuous floor guide helps to stabilise the sliding panels.

The drives are certified to DIN 18650/EN 16005, type-tested by TÜV and comply with the current directives and standards. The *EMT-F* drive system is tested and suitable for use in escape and rescue routes (AutSchR).



Convincing in detail:

- **Type rEMT-F:** redundant drive with 2 motors for use in escape and rescue routes
- Running smoothness thanks to large rollers
- Roller track warp resistance
- G30 profile system
- Fast opening speed of up to max. 0.9 m/s
- Clear and simple operation
- Optionally available with locking element integrated into the carriage or floor/hook bolt lock (optional)
- Self-learning control system with many connection and adjustment options
- Continuous floor guide (optional, recommended)

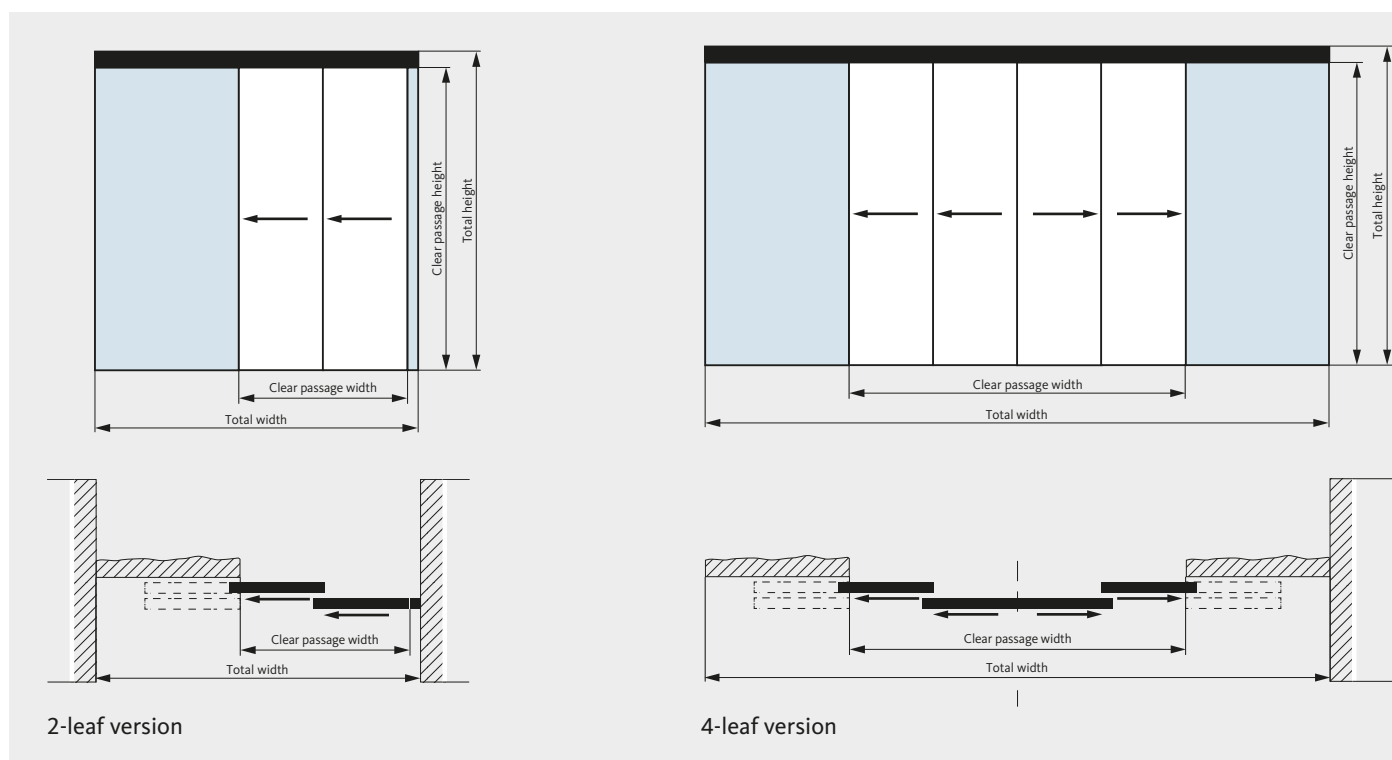

Designation	econoMaster EMT/econoMaster EMT-F	
	2-leaf	4-leaf
Use		
Clear passage width ^{[1][2]}	900–2500 mm	1400–3800 mm
Clearance height ^[1]	max. 3000 mm	
Drive height	145 mm	
Door leaf weight	max. 100 kg/leaf	max. 80 kg/leaf
Supply voltage	230 V/AC, 50 Hz	
Power consumption	max. 160 VA (50 VA during operation)	
Hold-open time	0–99 s	
Hold-open time with key impulse	0–99 s	
Opening speed	max. 0.9 m/s	
Closing speed	max. 0.5 m/s	
Winter opening width ^[2]	50%–100% of the clear opening width	
Protection type/Ambient temperature	IP20 (for dry rooms only)/–15 °C up to +50 °C	

[1] Standard dimensions, taking into account the overall measurement, the ratio of height and width and the local installation conditions; special solutions on request.

[2] The mandatory escape route width must be observed.

compactMaster CMR and CMR-F curved sliding door

Rounded out – sliding door with a revolving appearance



Absolutely sophisticated as an arch or complete circle

A curved sliding door unites the attractive appearance of a cylindrical door system with the benefits of an easily accessible sliding door. Whether in the form of a segmental arch, a semicircle, or a full circle up to a diameter of 4000 mm, the compactMaster CMR/CMR-F curved sliding door integrates perfectly into the architecture of a building.

Through the use of sophisticated profiles (G30 profile system), extensive transparency is combined with comprehensive functionality.

For escape and rescue routes, the *CMR-F* version offers broad opening widths up to 2500 mm.

The drives are certified to DIN 18650/EN 16005, type-tested by TÜV and comply with the current directives and standards. The *CMR-F* drive system is tested and suitable for use in escape and rescue routes (AutSchR).

In the *CMR RC3* and *CMR-F RC3* versions, the curved sliding doors are tested in accordance with EN 1627 to ensure they are burglar-inhibiting.



© EYE-SCREAM, Hansjörg Riedel

Convincing in detail:

- **Type CMR-F:** redundant drive with 2 motors for use in escape and rescue routes
- **Type CMR RC3/CMR-F RC3:** curved sliding door tested in accordance with EN 1627, in conjunction with sliding panels that can be locked manually using profile half cylinders on the inside as well as use of P5A glazing or a suitable filling.
- Running smoothness thanks to large rollers
- Fast opening speed of up to max. 0.9 m/s
- Clear and simple operation
- Integrated locking element at the sliding panel
- Self-learning control system with many connection and adjustment options
- Continuous floor guide

Options:

- Inclusion in building management systems and access controls
- LED spotlights for installation in the bottom of the aluminium ceiling
- Glass ceiling
- Air curtain system
- Loose-fixed flange connection
- Entrance mat

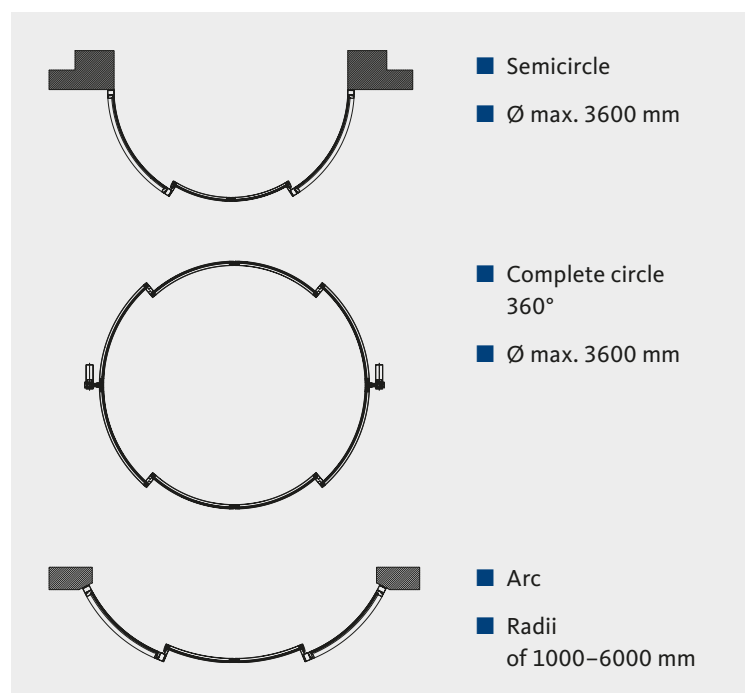

Designation	compactMaster CMR/compactMaster CMR-F	
	1-leaf	2-leaf
Use		
Clear passage width ^{[1][2]}	800–1250 mm	1000–2500 mm
Clearance height ^[1]	max. 2700 mm	
Drive height	115 mm	
Door leaf weight	max. 100 kg/leaf	
Supply voltage	230 V/AC, 50 Hz	
Power consumption	max. 160 VA (50 VA during operation)	
Hold-open time	0–99 s	
Hold-open time with key impulse	0–99 s	
Opening speed	max. 0.9 m/s	
Closing speed	max. 0.5 m/s	
Winter opening width ^[2]	50%–100% of the clear opening width	
Protection type/Ambient temperature	IP20 (for dry rooms only)/–15 °C up to +50 °C	

[1] Standard dimensions, taking into account the overall measurement, the ratio of height and width and the local installation conditions; special solutions on request.

[2] The mandatory escape route width must be observed.

compactMaster CMW and CMW-F prismatic sliding door

Entrance doors adapted to the building architecture



Visual accents for any desired angle

An exceptional sliding door to give the entrance area an individual touch. This means that every available angle between 90° and 179° can be realised. The corresponding safety sensors safeguard the main closing edge in accordance with DIN 18650/EN 16005.

The "true" drive height is 100 mm, meaning the door leaf's upper profile in the slim profile system is integrated into the drive and concealed by the cover. The prismatic sliding door can thus be easily and attractively integrated into all delicate substructures.



Convincing in detail:

- Type *CMR-F*: redundant drive with 2 motors for use in escape and rescue routes
 - Running smoothness thanks to rollers with an exchangeable rubber-coated running face
 - "True" height of drive: 100 mm
 - Fast opening speed of up to max. 0.9 m/s
- G30 profile system
 - Clear and simple operation
 - Optionally available with locking element integrated into the carriage or floor lock (optional)
 - Self-learning control system with many connection and adjustment options

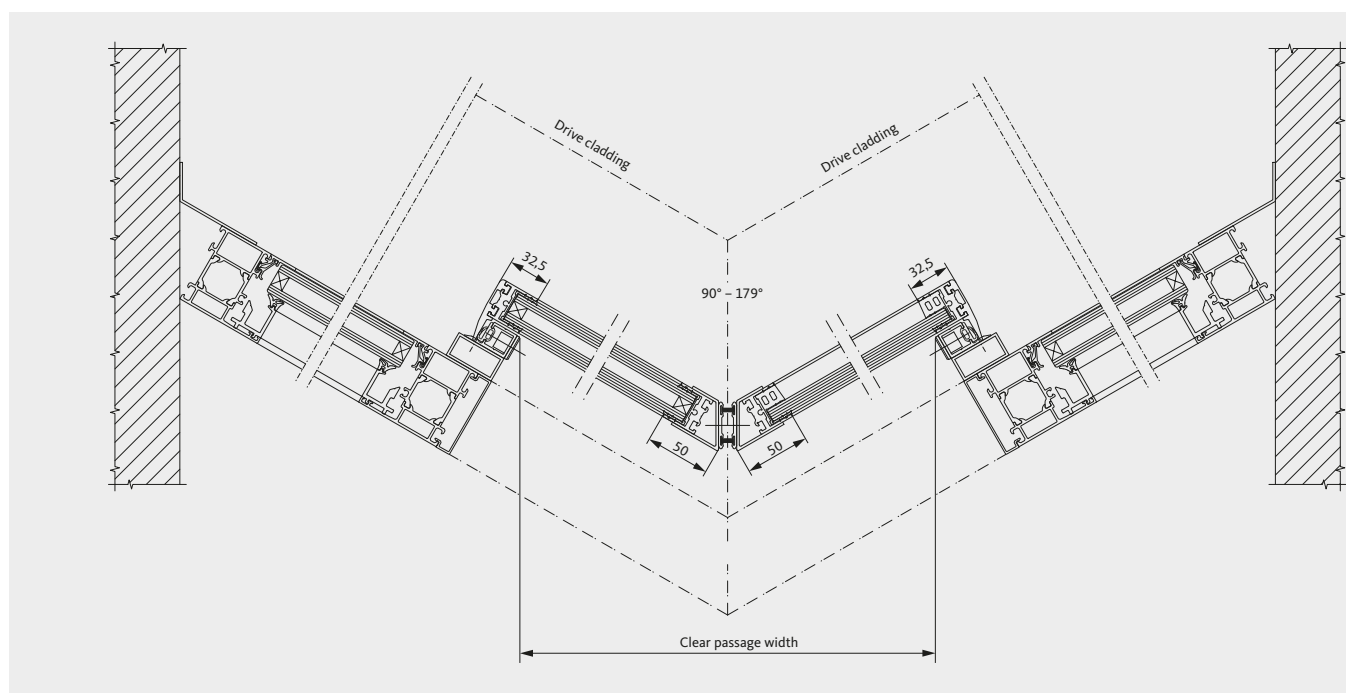

Designation	compactMaster CMW/compactMaster CMW-F
Use	2-leaf
Clear passage width ^{[1][2]}	900–2000 mm
Clearance height ^[1]	max. 2750 mm
Drive height	100 mm
Door leaf weight	max. 100 kg/leaf
Supply voltage	230 V/AC, 50 Hz
Power consumption	max. 160 VA (50 VA during operation)
Hold-open time	0–99 s
Hold-open time with key impulse	0–99 s
Opening speed	max. 0.9 m/s
Closing speed	max. 0.5 m/s
Winter opening width ^[2]	50%–100% of the clear opening width
Protection type/Ambient temperature	IP20 (for dry rooms only)/–15 °C up to +50 °C

[1] Standard dimensions, taking into account the overall measurement, the ratio of height and width and the local installation conditions; special solutions on request.

[2] The mandatory escape route width must be observed.

Sliding doors

Accessories – order information



POS-5 programme switch

- For setting the programme types: off/locked, exit, automatic, automatic winter, permanently open
- Key removable in every programme type
- Frame: white

Versions/Order numbers

Installation variants	Order numbers
Flush-mounted	A-8010680
Surface-mounted	A-8010670



POS-5 programme switch

- For setting the programme types: off/locked, exit, automatic, automatic winter, permanently open
- Key removable in every programme type
- Frame: stainless steel design

Versions/Order numbers

Installation variants	Order numbers
Flush-mounted	A-8010890
Surface-mounted	A-8010910



E-POS-5 programme selection switch

- For setting the programme types: off/locked, exit, automatic, automatic winter, permanently open
- In conjunction with a PC key switch for escape sliding doors
- Frame: white

Versions/Order numbers

Installation variants	Order numbers
Flush-mounted	A-8011730
Surface-mounted	A-8011620



E-POS-5 programme selection switch

- For setting the programme types: off/locked, exit, automatic, automatic winter, permanently open
- In conjunction with a PC key switch for escape sliding doors
- Frame: stainless steel design

Versions/Order numbers

Installation variants	Order numbers
Flush-mounted	A-8011750
Surface-mounted	A-8011770



Radar motion sensor with safety light curtain to DIN 18650/EN 16005

IXIO-DT3

- Direction detection
- Self-monitoring for use in escape route sliding doors
- Testable presence curtain, 2 rows

Versions/Order numbers

Colour	Order numbers
Black	A-7153610
White	A-7154560



IXIO-VIO RA rain cover

- To minimise control errors in rainy conditions

Versions/Order numbers

Colour	Order numbers
Black	A-7156370



IXIO-ST protection sensor in accordance with DIN 18650/EN 16005

- Testable presence curtain, 2 rows
- To secure the passage area

Versions/Order numbers

Colour	Order numbers
Black	A-7153630
White	A-7154570



Radar motion sensor

Eagle ONE

- Direction detection

Eagle THREE N

- Direction detection and self-monitoring
- For use in sliding doors, escape and rescue routes (inside, in the escape direction)

Versions/Order numbers

Designation	Order numbers
Radar Eagle ONE	A-7023370
Radar Eagle THREE N	A-7117420



Eagle ORA rain cover

- To minimise control errors in rainy conditions

Versions/Order numbers

Designation	Order numbers
Eagle ORA rain cover	A-7135030



Magic Switch impulse transmitter

- For contact-free control of automatic doors
- Activation through hand movement, direction-sensitive
- Distance: 20–50 cm

Versions/Order numbers

Designation	Order numbers
Magic Switch impulse transmitter	A-7032820



Elbow push-button

- Large-surface push-button in surface-mounted version
- Including sticker "Press here"

Versions/Order numbers

Designation	Order numbers
Elbow push-button Grey	A-8001940
Elbow push-button silver	A-8003560



Key switch for narrow stile doors

- For profile half cylinder to be provided by customer
- Change-over contact
- Protection class: IP44
- Dimensions: 40 x 86 x 15 mm

Versions/Order numbers

Finish	Order numbers
Silver (RAL 9006)	A-8002040
Black (RAL 9005)	A-8003460
White (RAL 9016)	A-8003600



Key switch

- For 27 mm profile half cylinder to be provided by customer
- Switch contact
- Grey frame (standard)
- Dimensions
 - Flush-mounted: 100 x 100 x 71 mm
 - Surface-mounted: 70 x 80 x 71 mm

Versions/Order numbers

Installation variants	Order numbers
Flush-mounted	A-7025570
Surface-mounted	A-7025550



Code keypad

- For control of doors by means of a numerical code
- Suitable for outside use (IP65)
- Dimensions: 80.5 x 80.5 x 30 mm

Versions/Order numbers

Installation variants	Order numbers
Flush-mounted/ surface-mounted	B-55600-20-1-8

Evaluation unit

- For inside use
- Dimensions: 66 x 89 x 33 mm



Code keypad

- For control of doors by means of a numerical code
- Suitable for outside use (IP65)
- Dimensions: 80 x 80 x 12 mm

Versions/Order numbers

Designation	Order numbers
Code keypad	A-7109120
Evaluation unit	A-7109130

Evaluation unit

- For inside use
- Dimensions: 110 x 180 x 40 mm



Mechanical floor lock

- For mounting on sliding door panels
- It can also be locked on both sides with appropriate processing of the G30 slim profile system (customer-provided profile cylinder)

Versions/Order numbers

Finish	Order numbers
in door system colour	A-8007080
E6 / EV1	A-8009570
RAL 9016	A-8009580

Greater opportunities for challenging architectural solutions

Swing-door drives open up new opportunities: automatic opening and closing fire and smoke protection doors as well as interior and exterior doors increase freedom of movement and safety in public buildings. Comfortable access is provided via radar motion sensors, push-buttons or an access control system. A combination of multi-point lock and motor-driven shoot-bolt lock is recommended for entrance doors in the facade. This makes accessibility, burglar protection and escape route safety a reality.





3.1

Swing door drive DTN 80

Accessibility and comfort even for noise-sensitive areas



High-performance on standard and fire protection doors

The DTN 80 swing-door drive can be used on doors with any frame material. It can be supplied in various finishes. Automation of existing swing doors is possible at any time by retrofitting.

The DTN 80 swing-door drive is the perfect solution for barrier freedom at fire protection doors, such as those found in hospitals and residential homes. This is because the DTN 80 swing-door drive is able to overcome any spring force that may be present

at fire and smoke protection doors in normal mode: in the event of fire, they must be able to close safely purely by means of the spring force. The DTN 80 thus ensures barrier-free access on a daily basis.

The drive is type-tested by TÜV according to EN 16005 and approved for use on fire protection doors by German Institute of Building Technology (DIBt).



Convincing in detail:

■ Universal use:

all applications can be implemented using only one swing-door drive:

- 1- and 2-leaf swing doors
- Fire doors
- Escape doors
- Push-open or pull-open

■ Closing force instead of latching speed

■ Patented energy-store consisting of two spring assemblies which can be adjusted separately

■ Convenient adjustment options directly at the drive via the rotary knob/push-button with integrated display under the drive cladding

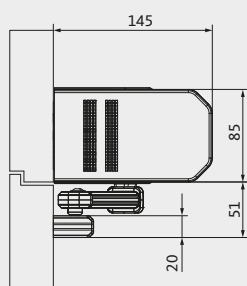

Transom installation
Side opposite to hinges – slide rail

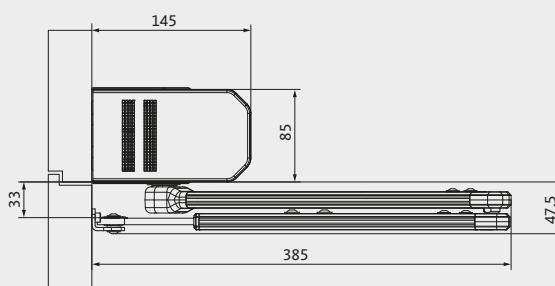

Transom installation
Side opposite to hinges – scissor-action arm

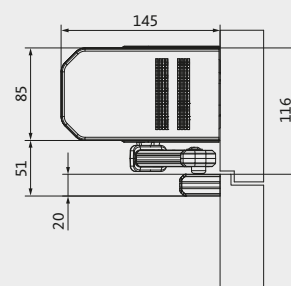

Transom installation
Hinge-side – slide rail

Designation	Swing door drive DTN 80
Height x Depth x Length	85 x 145 x 680 mm ^[1]
Weight	11 kg
Leaf width (1-leaf)	700–1600 mm
Closing force sizes for fire protection doors	EN 3–EN 7
Distance between hinges (2-leaf)	1450–3200 mm
Mass inertia, max.	190 kg/m ² ^[2]
Torque, max.	260 Nm
Max. door leaf weight	600 kg
Current consumption for external devices, max.	24 V DC/2.5 A
Opening angle, max.	135°
Lintel depths, scissor-action arm	0–300 mm
Lintel depths, slide rail	+10/–10 mm
Axle extensions	30, 60 und 90 mm
Power consumption max.	80 W
Standby operation	7 W
Ambient temperature	–15 °C to +50 °C
Protection type	IP20
Test cycles according to DIN 18263-4	500,000
Test cycles according to EN 16005	1,000,000

[1] Drive height also with 2-leaf doors with integrated closing sequence control

[2] Depending on scissor-action arm

Automatic revolving doors and controlled physical access systems

For entrances that are sure to make an impression.

Revolving doors are used wherever impressive entrances are needed. They are primarily used to provide public buildings, hotels, banks, insurance offices or airports with a striking entrance.

Security revolving doors and security curved sliding doors are used for any entrance that requires extra security. In particular, they provide banks, insurance offices, government ministry buildings, authorities, data centres, industrial plants or office buildings with extra security and convenience.





GRA and GRA-F standard revolving door

Individual solutions are standard



Effective protection against draughts, cold and dirt

Standard revolving doors ensure building entrances are functional, draught-excluding and soundproof. The flexible design and multitude of options allow for individual solutions varying in function, appearance and size. The standard revolving door can be operated manually, semi-automatically by activating the Push&Go function or automatically by activating the radar sensors, as required.

The drum walls may be designed with glass but also with heat-insulated panels of sheet metal. Regardless of the option chosen, user safety is always the top priority. The semi-automatic and automatic revolving door are type-tested by TÜV to DIN 18650 and EN 16005 and comply with the current standards and regulations.



Hyatt Regency Düsseldorf Projektgesellschaft Hafenspitze mbH, Düsseldorf, Germany/Photo: www.mirahampe.de

Convincing in detail:

- Individual solutions through variable design with a multitude of options
- Turnstile of slim-profile aluminium-glass construction
- Drum walls made of curved 10 mm laminated sheet glass (LSG) or heat-insulated sheet-metal panels
- *GRA-F* version with folding leaves, suitable for use in escape and rescue routes [1]. The leaves are held securely with magnetic locks in normal operation
- Type *GRA RC3/GRA-F RC3*: tested to EN 1627 in conjunction with inside night sliding doors
- Minimal crown height: 175 mm *GRA*, 350 mm *GRA-F*
- Electromechanical locking at the turnstile (only for the automatic version) or with mechanical shoot-bolt locks
- Push&Go function can be activated
- Speed limiter for manual revolving doors (optional)

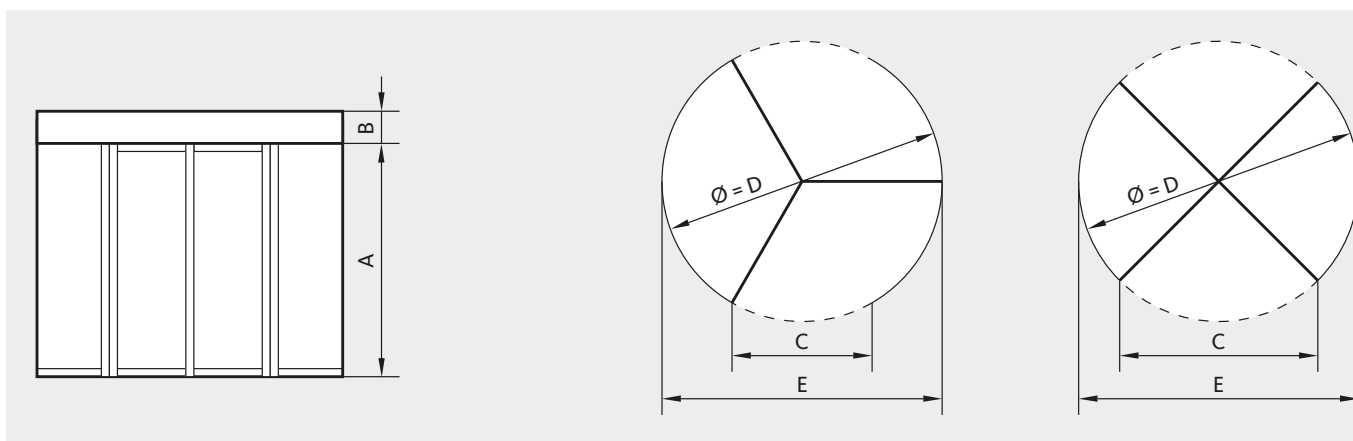

Options:

- Folding mechanism for summer position (*GRA-F* type)
- Manual or automatic night locking sliding doors
- Air curtain systems in different versions
- LED lamps in the ceiling
- Stainless steel bottom ring
- Entrance mat
- Loose-fixed flange connection
- Horizontal or vertical door handles for manually-operated revolving doors

GRA/GRA-F standard revolving doors

D*	A*	B*	C/3-leaf	C/4-leaf	E
1800	2100-3000	175-800	~830	~1220	1860
2000	2100-3000	175-800	~920	~1350	2060
2200	2100-3000	175-800	~1010	~1490	2260
2400	2100-3000	175-800	~1105	~1620	2460
2600	2100-3000	175-800	~1195	~1760	2660
2800	2100-3000	175-800	~1285	~1890	2860
3000	2100-3000	175-800	~1375	~2030	3060
3200	2100-3000	175-800	~1465	~2160	3260
3400	2100-3000	175-800	~1555	~2290	3460
3600	2100-3000	175-800	~1645	~2430	3660
3800	2100-3000	175-800	~1690	~2490	3860

*Special dimensions available on request

[1] Observe country-specific directives

GGG all-glass revolving door

Perfect integration of the entrance area into glass facades



Sophisticated and inviting

All-glass revolving doors are not just functional, but also extremely impressive. The minimal profile sizes allow for maximum transparency, even with automatic all-glass revolving doors, since the drive is located in the floor.

Customer-specific adaptations and suggestions, such as swing-out leaves for summer opening or an automatic night shield, can always be included and implemented quickly. The semi-automatic and automatic revolving door are type-tested by TÜV to DIN 18650 and EN 16005 and comply with the current standards and regulations.



Schott AG, D-Mainz/Photo: www.gruppe-vier.de

Convincing in detail:

- Narrow profiles
- Turnstile of slim-profile aluminium-glass construction
- In manual, semi-automatic and fully automatic versions
- Manual and automatic night shield
- Electromechanical locking at the turnstile (only for the automatic version) or with mechanical shoot-bolt lock
- Push&Go function can be activated

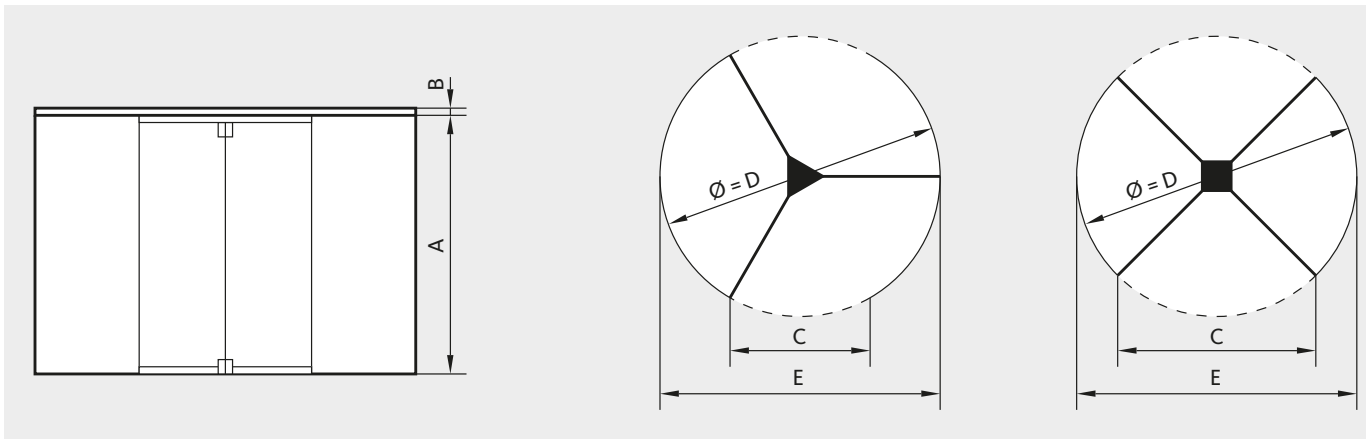

Options:

- Manual or automatic night locking sliding doors
- Horizontal or vertical door handles for manual operation
- Loose-fixed flange connection
- Floor pan
- Air curtain system, vertical

GGG all-glass revolving door

D*	A*	B**	C/3-leaf	C/4-leaf	E
1800	2100-3000	16	~830	~1220	1860
2000	2100-3000	16	~920	~1350	2060
2200	2100-3000	16	~1010	~1490	2260
2400	2100-3000	16	~1105	~1620	2460
2600	2100-3000	18	~1195	~1760	2660
2800	2100-3000	18	~1285	~1890	2860
3000	2100-3000	18	~1375	~2030	3060

* Special dimensions available on request* ** Or according to structural requirements**

GGR large-capacity revolving door

Comfortable entry, even in high-traffic areas



High flow capacity and suitable for use as an escape door

For large visitor flows and use in escape and rescue routes, the large-capacity revolving door is the elegant and energy-saving entrance solution. This door combines modern design with high functionality in an ideal way. For example, comfortable passage with shopping carts and prams or wheelchairs is always possible. The leaves are divided in two and held securely with magnetic

locks in normal operation. In the event of a fire or a power failure, or if the emergency push-button has been pushed, the panel fixation is released so the sliding panels can be folded away around the centre column in the escape direction. The fully automatic revolving door is safeguarded with sensors and contact strips in accordance with the current standards DIN 18650 and EN 16005 and is type-tested by TÜV.



FMO Airport Münster/Osnabrück GmbH, D-Greven/Photo: www.mirahampel.de

Convincing in detail:

- Ideal for heavy visitor traffic
- Offers plenty of space for shopping carts, prams, wheelchairs
- Suitable for use in escape and rescue routes ^[1] due to foldable leaves, which are securely fixed in normal operation
- Different materials and finishes for individual solutions
- Manual or automatic night shield
- Locked with shoot-bolt lock on the door leaves or night shield

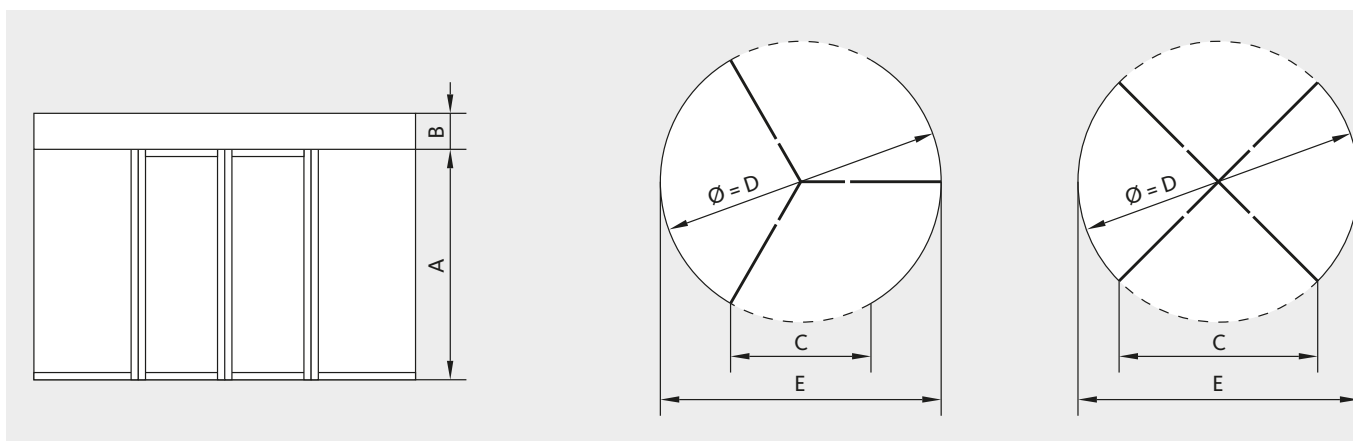

Options:

- Drum walls made of curved 10 mm laminated sheet glass (LSG) or heat-insulated sheet-metal panels
- Outdoor roof is waterproof
- LED lamps in the ceiling
- Entrance mat
- Loose-fixed flange connection
- Floor ring
- Floor pan
- Air curtain systems in different versions

GGR large-capacity revolving door

D*	A*	B*	C/3-leaf	C/4-leaf	E
3600	2100–2500	410–800	~1630	~2408	3720
4800	2100–2500	410–800	~2230	~3257	4920
5400	2100–2500	410–800	~2530	~3681	5520
6000	2100–2500	410–800	~2830	~4105	6120

*Special dimensions on request, in increments steps up to diameter 6200 mm

[1] Observe country-specific directives

GSJ security revolving door

Secure access control and fast passage



Access controlled in both directions

Access to high-security buildings or areas within a building can be controlled through security revolving doors. Besides functionality, the building architecture is taken into consideration according to the customer's wishes, so a tailor-made solution always results.

In the initial position, the security revolving door is locked by means of a motor-driven brake system. An access control system releases it. Unauthorised persons are conducted out of the security revolving door in the exit direction.



Convincing in detail:

- Access control, even in high-traffic areas
- Access control in both directions
- Draught-free and always soundproof access control
- Manual or automatic night shield
- Contact floor mat for monitoring
- Electro-motorised locking at the turnstile and/or with mechanical shoot-bolt locks
- Easy adaptation to on-site access control systems
- Different materials and finishes for individual solutions

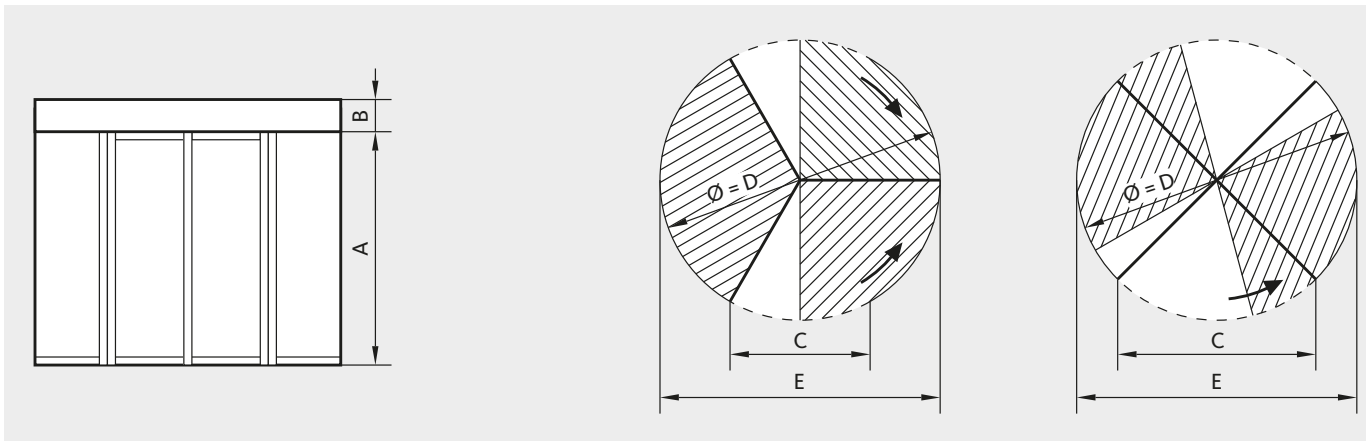

Options:

- Drum walls made of curved 10 mm laminated sheet glass (LSG) or heat-insulated sheet-metal panels
- Safety glass
- LED spotlights for installation in the aluminium ceiling
- Outdoor roof is waterproof
- Floor ring
- Loose-fixed flange connection

GSI security revolving door					
D*	A*	B*	C/3-leaf	C/4-leaf	E
1800	2100-3000	350-800	~859	~1239	1860
1900	2100-3000	350-800	~907	~1308	1960
2000	2100-3000	350-800	~954	~1377	2060
2100	2100-3000	350-800	~1002	~1446	2160

*Special dimensions available on request

GS1 security curved sliding door

Controlled physical access and transparency



Comfort in the narrowest space

Access control possible in the narrowest space thanks to a minimal diameter of one metre. A sense of transparency is retained thanks to the high proportion of glass. 2-zone contact floor mat is used to monitor the passage area for an authorised or unauthorised user. The door leaves are locked in the initial position by an electro-mechanical locking mechanism. If authorisation is granted by an access control system, the door opens automatically.

As soon as the user steps on the contact mat, the access door will close. As soon as the door has closed, the door opposite opens automatically. The user can now exit the passing area. Unauthorised access causes the passing cycle to be interrupted. The corresponding door will remain open until the passing area is empty again.



© EYE-SCREAM, Hansjörg Riedel

Convincing in detail:

- Access control in the narrowest space, from a diameter of 1 m
- Sense of spaciousness and transparency due to large proportion of glass
- Based on the tried and tested quality of our CMR curved sliding door drive
- Controlled physical access and cabin monitoring by means of 2-zone contact floor mat
- Easy adaptation to on-site access control systems
- EMERGENCY-OPEN switch in the cabin for opening the outer door

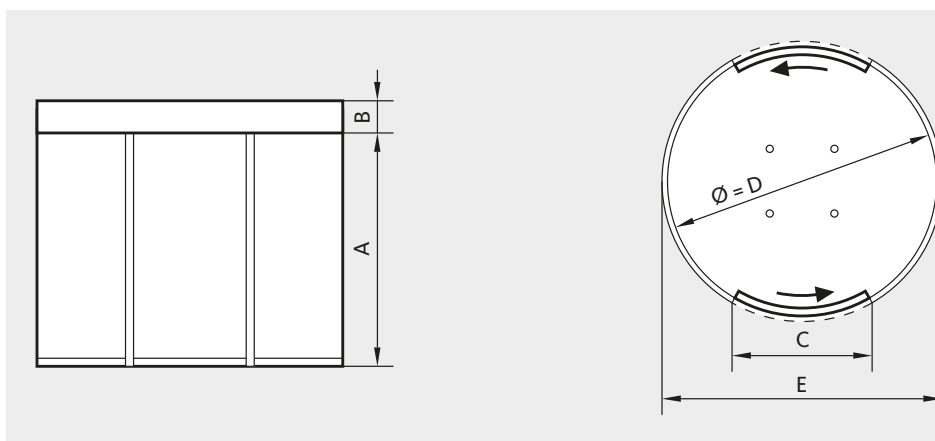

Options:

- Sliding panels and drum walls made of curved 10 mm laminated safety glass (LSG)
- LED spotlights for installation in the aluminium ceiling
- Presence sensors for safeguarding main closing edges
- Loose-fixed flange connection
- Floor ring
- Available in different finishes and colours

GSI security curved sliding door				
D*	A*	B*	C	E
1300	2100-3000	350-800	~600	1360
1500	2100-3000	350-800	~700	1560

*Special dimensions available on request

Highly flexible in terms of design and use of space.

Elegant appearance, flexible in terms of use of space and minimal space requirements: the benefits of all-glass sliding walls are most evident in public areas. As partition walls, the all-glass sliding wall systems from the GU group offer modern solutions that combine maximum accessibility with a high level of versatility.

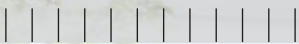



shopMaster GSW-M all-glass system

The modular all-glass sliding wall system



Flexible and transparent

The shopMaster GSW-M all-glass sliding wall system enables the creation of a multitude of individual partition walls and shop fronts for shop-in-shop concepts. Solutions can be implemented for practically any floor plan, giving completely free reign to the creativity of the planners. Depending on the equipment, the all-glass sliding wall system is available with a linear, curved or segmented design. The units can be arranged in a variety of ways – a floor guide is not needed.

The system's compact design requires only minimal space for the roller track and parking niche. Passage openings can be implemented using side-hung end panels. The running mechanisms are equipped with high-quality, ball-bearing-supported rollers and guarantee permanently reliable operation and smooth movement of the elements during opening and closing. In the event of the glass breaking, the clamping profiles are protected from falling out by special door hardware.



© EYE-SCREAM, Hansjörg Redel

Convincing in detail:

- Modular design with prefabricated function elements
 - No continuous floor guide required
 - High-quality plastic-coated, ball-bearing-supported running mechanisms
- Two-part roller track allows flexible creation of curves
 - Locking elements for segmented systems

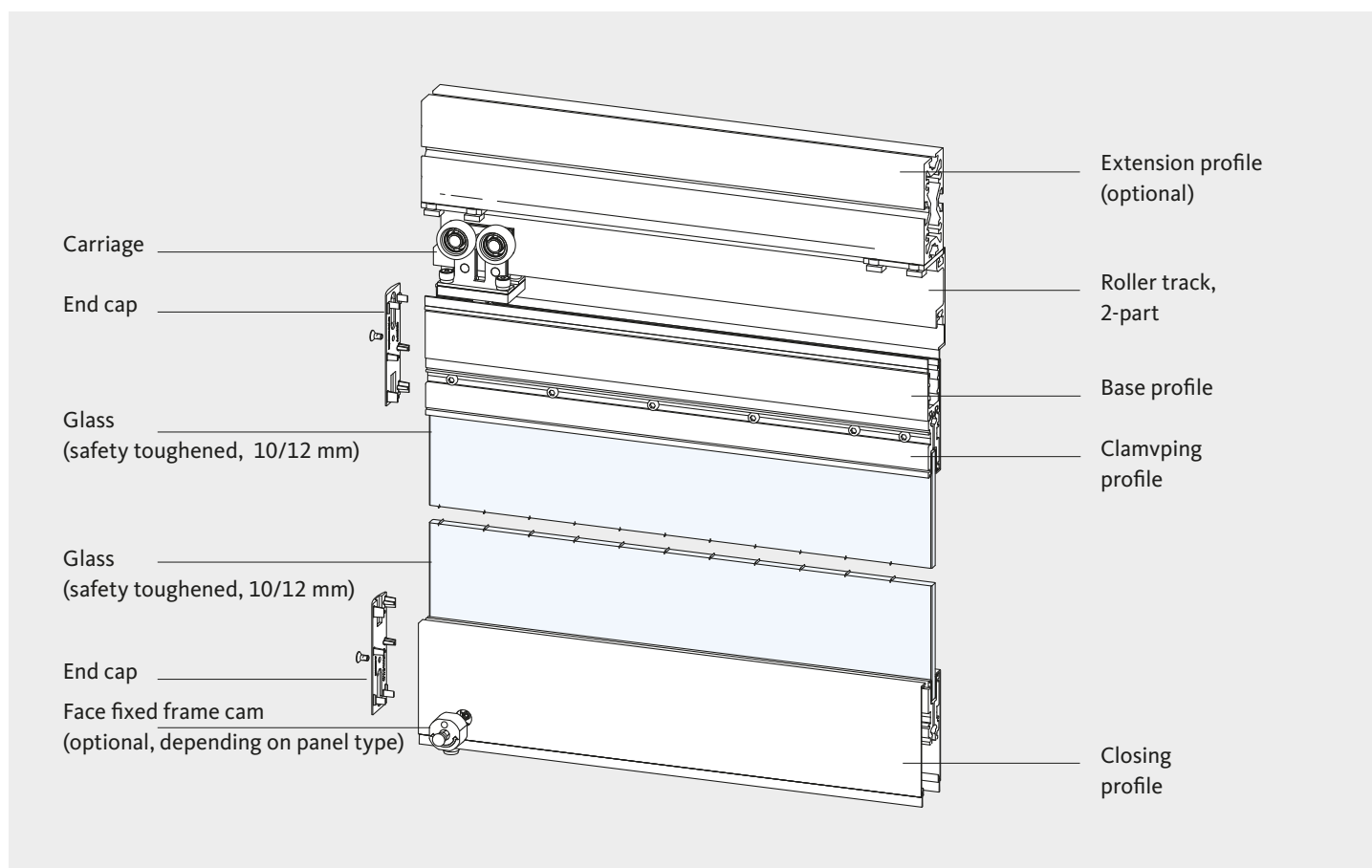

Designation	shopMaster GSW-M
Max. element height	3500 mm*
Max. element width	1250 mm*
Max. element weight	150 kg
Possible glass thicknesses	10/12 mm
Roller track version	Linear/angled/segmented/curved from a radius of 6000 mm
Finishes	Silver colour E6/EV1 anodised RAL colour on request (powder coating) Stainless steel look
*Special solutions on request	

shopMaster GSW-A all-glass wall system

Convenience and safety with automatically driven elements



Exclusive and convenient

The automatic all-glass sliding wall system shopMaster GSW-A offers a wide variety of design options for architects and planners as well as maximum convenience for operators or users. The system's compact design requires only minimal space for the roller track and parking niche. The modules are equipped with state-of-the-art carriage technology with plastic-coated, ball bearing-supported rollers.

These guarantee permanently reliable operation and noiseless movement of the elements. Thanks to the small roller track installation height of 86.5 mm, installation flush with the ceiling is possible almost everywhere. The required floor guide provides additional stability and utmost convenience to the user. For safety reasons, the automatic all-glass sliding wall can be moved by hand in the event of a power failure.



Convincing in detail:

- Small installation height
- Distance between moving panels adjustable: 50–1500 mm
- High-quality plastic-coated, ball-bearing-supported running mechanisms
- Continuous floor guide
- Panels movable by hand in the event of a power failure
- Optionally available with fully automatic wall cover for parked panels

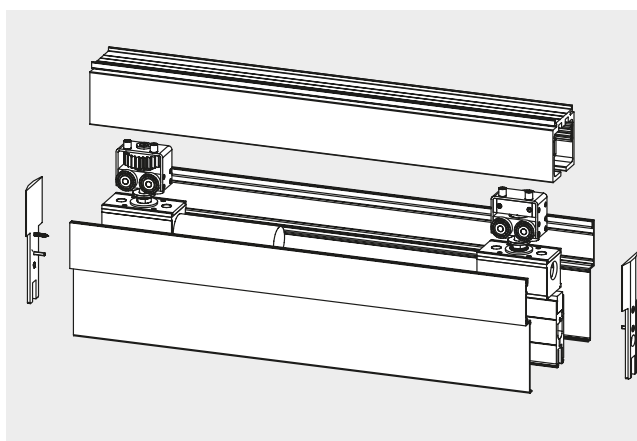

Sliding panel

with drive module and current collecting module, each positioned above the base profile; floor guidance is provided by the roller pin running in the floor rail.

Side-hung end panel

opens and closes automatically as the all-glass sliding wall is released or locked, respectively.

Functional features:

- Obstacle recognition
- Maximum bump force 150 N
- Automatic locking
- Decelerated speed into the end positions
- Emergency unlocking via profile cylinder

Designation	shopMaster GSW-A
Max. element height	3500 mm*
Max. element width	1250 mm*
Max. element weight	150 kg
Max. number of elements	32
Possible glass thicknesses	10/12 mm
Nominal voltage	230 V AC, 50 Hz
Nominal power	230 W
Fail-secure	24 V DC
Ambient temperature	-15 °C to +50 °C
Protection class	IP20
Speed	Adjustable from 50–150 mm/s
Roller track version	Linear/angled/curved from a radius of 6000 mm*
Finishes	Silver colour E6/EV1 anodised RAL colour on request (powder coating) Stainless steel, matt brushed**
Special solutions on request* Module cladding anodised similar to stainless steel**	

The GU pledge

Tested safety



Safety: successfully certified



EN 16005 – Safety in use of power operated pedestrian door systems

The EN 16005 regulates safety for automatic door systems throughout Europe.

Besides product and safety requirements, it describes the acceptance inspection at the installation location, maintenance and regular checks.

Through a type test, the TÜV confirms that the requirements from the relevant standards and directives are met.

But it does not take into account the hazards resulting from local conditions or the specific building use.

And so before installation and commissioning of the system, a risk analysis that takes the local conditions into account must be performed.

Ideally, the safety concept will be coordinated with the customer or operator in the planning phase.

The Gretsch-Unitas group offers:

- Individual advice
- Qualified project handling
- Professional installation
- Reliable service

This ensures that commissioning takes place without unpleasant surprises. All required safety components are taken into account and need only be tested for proper functioning at start-up.



Getty Images

Advice right from the planning stage



TÜV type-tested



Peace of mind with high-quality production

More than 100 years of experience

Worldwide presence

System solutions in the project

Safety check and maintenance

Regular, professional maintenance is the best guarantee of maintaining the value and functional safety of automatic doors over the years.

In Germany, GU Automatic GmbH installs automatic sliding doors, swing door drives, revolving doors, all-glass sliding walls, security doors and industrial door systems

After-sale service directly from the manufacturer with its own personnel, optimal product knowledge and use of original replacement parts ensures the greatest functional availability of automatic door systems. Short travel times are ensured through a comprehensive network of service installers.

An automatic door system or industrial door system must also be tested at least once per year by an expert. Besides this safety check, maintenance according to the manufacturer's specifications must be performed. Ideally, this takes place at the same appointment.

The service contract

A service contract for automatic door systems and industrial door systems offers many advantages:

- Early recognition of wear ensures operational and personal safety
- Unplanned service work is markedly reduced
- Regular inspection of safety components minimizes the operator's potential liability risk
- Provision and updating of a system-specific inspection book
- Possible hazards resulting from a change in use are recognized and can be eliminated
- Service customers receive discounts on parts prices and pay fixed travel fees



Professional installation



Logistics – just-in-time wherever you are

kab planungsbüro für bauleistungen gmbh, feilbach



Service and maintenance

Special solutions development

Modular system technology

Products in stock around the globe



Copyright notice

© All illustrations and texts in this publication are protected by copyright. Unless otherwise stated in the image credits, the rights belong to the Gretsch-Unitas group. Any use of copyright protected materials without the consent of the holder of the rights is prohibited.

Image credits

Pages 6, 8, 10, 16, 38, 42, 44 © EYE-SCREAM, Hansjörg Riedel
Page 30 Hyatt Regency Düsseldorf Projektgesellschaft Hafenspitze mbH, D-Düsseldorf/Photo: www.mirahampel.de
Page 32 Schott AG, D-Mainz/Photo: www.gruppe-vier.de
Page 34 FMO Airport Münster/Osnabrück GmbH, D-Greven/Photo: www.mirahampel.de
Page 46 Photo on left: Getty Images
Page 47 Photo in centre: With kind permission of kab planungsbüro für bauleistungen gmbh, Fellbach

Publisher
Gretsch-Unitas GmbH
Baubeschläge
Johann-Maus-Str. 3
71254 Ditzingen, Germany
Tel. +49 71 56 3 01-0
Fax +49 71 56 3 01-2 93
www.g-u.com





WINDOW TECHNOLOGY
DOOR TECHNOLOGY
AUTOMATIC ENTRANCE SYSTEMS
BUILDING MANAGEMENT SYSTEMS

Gretsch-Unitas GmbH
Baubeschläge
Johann-Maus-Str. 3
71254 Ditzingen, Germany
Tel. +49 (0) 71 56 3 01-0
Fax +49 (0) 71 56 3 01-77 980

GU Automatic GmbH
Karl-Schiller-Straße 12
33397 Rietberg, Germany
Tel. +49 5244-9075-100
Fax +49 5244-9075-599

Gretsch-Unitas AG
Industriestr. 12
3422 Rüttiligen
Switzerland
Tel. +41 (0) 34 44845-45
Fax +41 (0) 34 445 62-49

GU Baubeschläge Austria GmbH
Mayrwiesstr. 8
85300 Hallwang
Austria
Tel. +43 (0) 662 66 48 30
Fax +43 (0) 662 66 48 30-3 01

www.g-u.com
www.gu-automatic.de

Securing technology for you
Vorsprung mit System

